

Evaluates: MAXM20343 and MAXM20344 Modules in 3.3V and 5V Output-Voltage Application

## General Description

The MAXM20343/MAXM20344 evaluation boards provide a proven design to evaluate the performance of the MAXM20343/MAXM20344 modules. Each of these modules operate over an input range from 0.5V to 5.5V and deliver up to 2.5W output power. The modules are configured to demonstrate optimum performance and component sizes in the evaluation boards.

The MAXM20343 module is configured for a 3.3V output, delivering up to 2.5W, over a 0.5V to 5.5V input range.

The MAXM20344 module is configured for a 5V output, delivering up to 2.5W, over a 0.5V to 5.5V input range.

The evaluation boards feature fixed soft-start, INGOOD and PGOOD signals. The MAXM20343/MAXM20344 module family data sheet provides a complete description of the parts that should be read in conjunction with this data sheet prior to operating the evaluation boards.

## Features and Benefits

- 0.5V to 5.5V Input Range
- MAXM20343 Offers High 94% Efficiency ( $V_{IN} = 3.3V$ ,  $V_{OUT} = 3.3V$ ,  $I_{OUT} = 300mA$ )
- MAXM20344 Offers High 94.5% Efficiency ( $V_{IN} = 3.3V$ ,  $V_{OUT} = 5V$ ,  $I_{OUT} = 300mA$ )
- Fixed 32ms Soft-Start Time
- INGOOD and PGOOD Outputs with Pullup Resistor to the Respective OUT
- Low-Profile, Surface-Mount Components
- Proven PCB Layout
- Fully Assembled and Tested

## Quick Start

### Required Equipment

- One 0.5V to 5.5V DC, 2A power supply
- Digital multimeters (DMM)
- Load resistors capable of sinking up to 0.75A at 3.3V, and 0.5A at 5V

### Procedure

The evaluation board is fully assembled and tested. Follow the steps below to verify and test individual modules operation.

**Caution:** Do not turn on the power supply until all connections are complete

1. Disable the power supply and set the input power supply at a voltage between 2.1V and 5.5V.
2. Connect the positive terminal and negative terminal of the power supply to the IN pad and its adjacent AGND pad of the module under evaluation.
3. Connect a resistive load across the OUT pad and its nearest AGND pad of the corresponding module.
4. Verify that the shunts are installed on jumpers (JU101, JU201) (see [Table 1](#) for details).
5. Connect digital multimeter (in voltage measurement mode) across the OUT and its respective AGND pad.
6. Turn on the input power supply.
7. Verify that the digital multimeter displays expected terminal voltage with respect to AGND.

**Ordering Information appears at end of data sheet.**

**MAXM20343/MAXM20344 Evaluation Board Configuration**

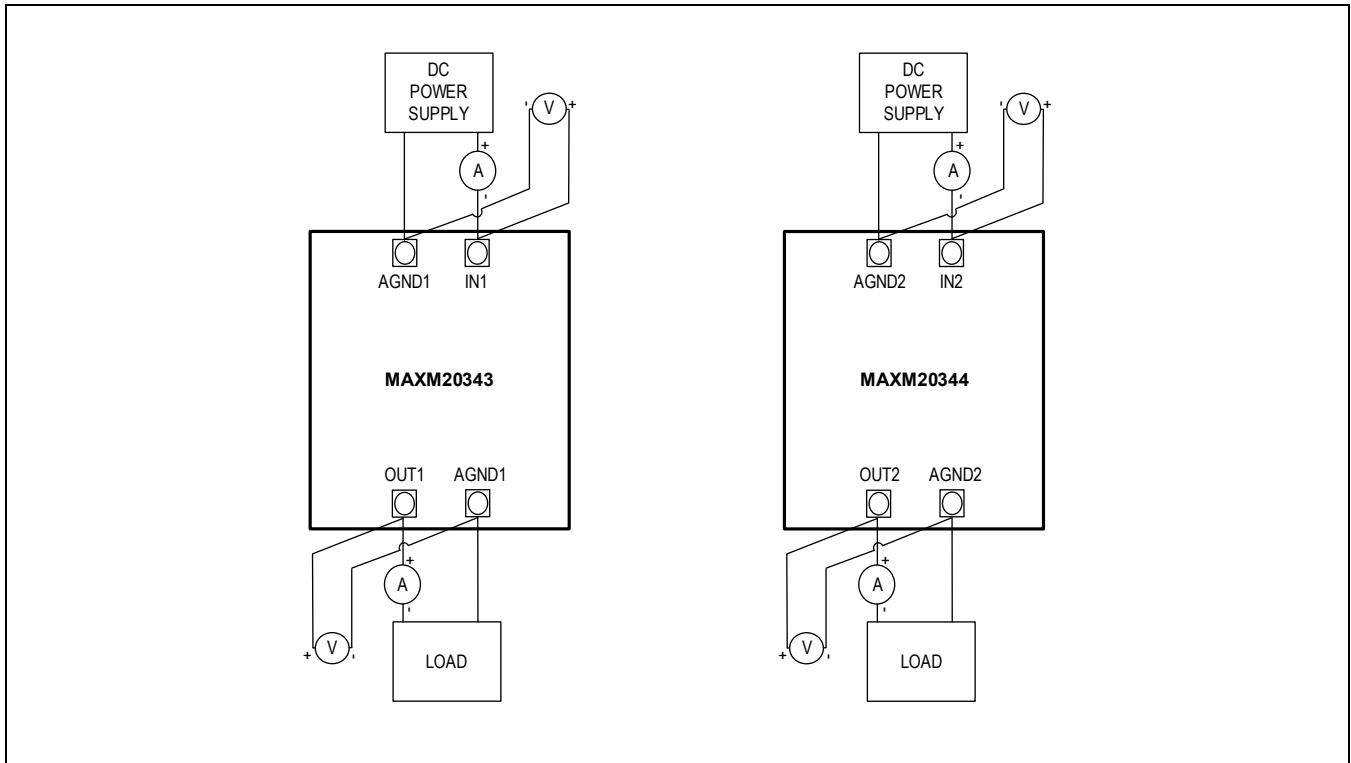

## Typical Performance Characteristics

$T_A = 25^\circ\text{C}$ , all measurements are in reference to [MAXM20343 Evaluation Board Schematic](#), unless otherwise noted.

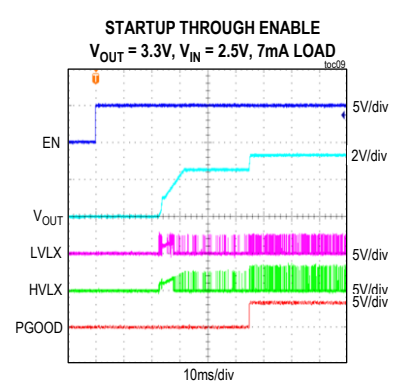
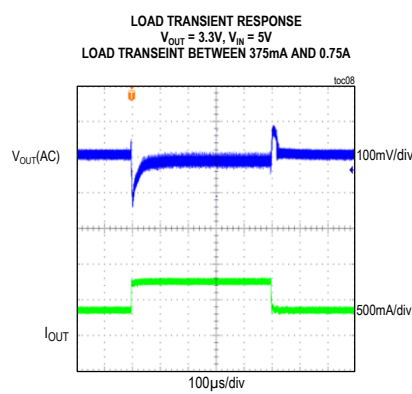
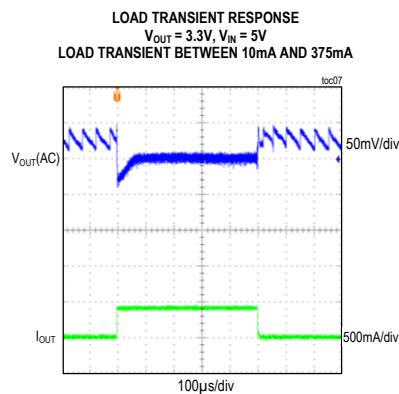
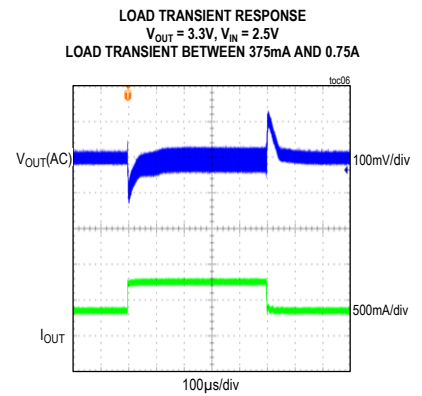
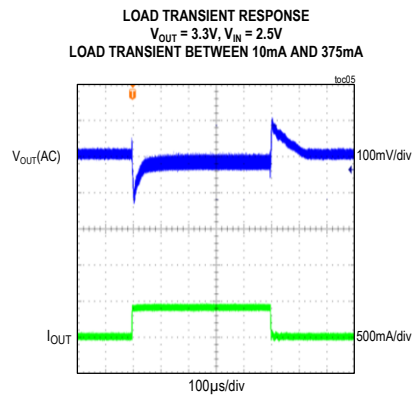
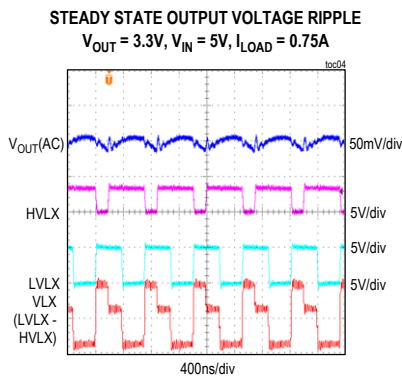
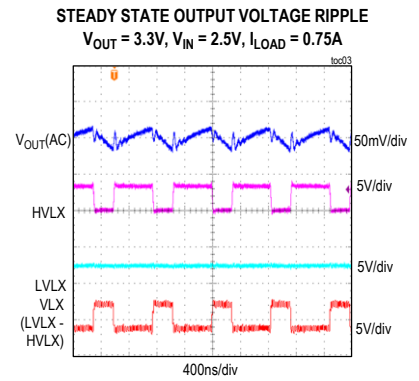
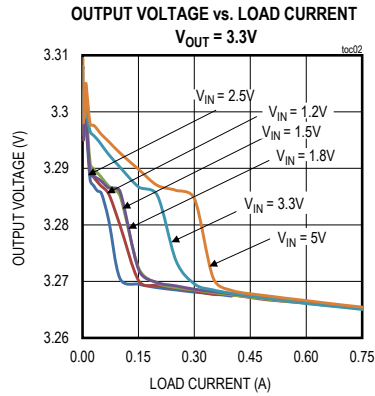
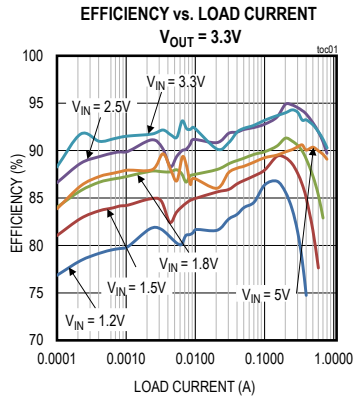

## Typical Performance Characteristics

T<sub>A</sub> = 25°C, all measurements are in reference to [MAXM20343 Evaluation Board Schematic](#), unless otherwise noted.

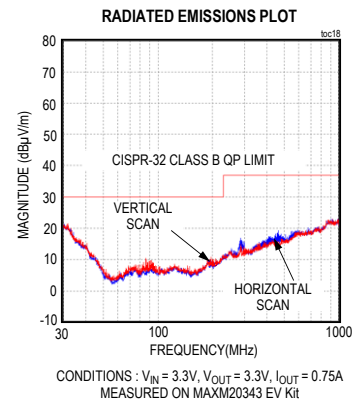
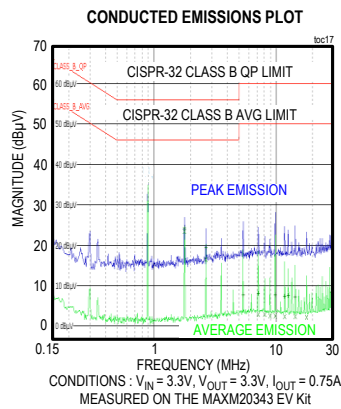
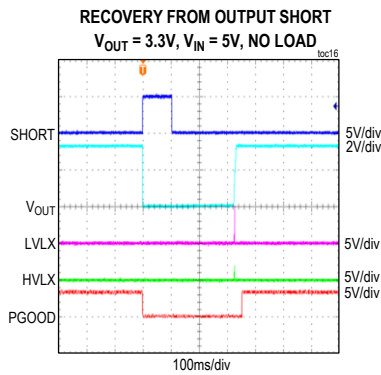
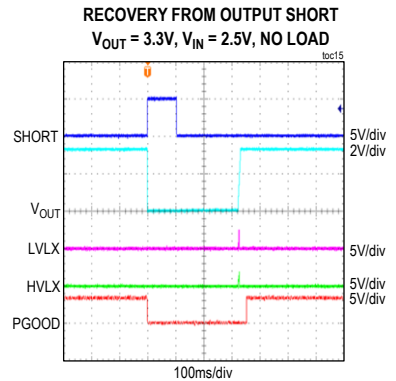
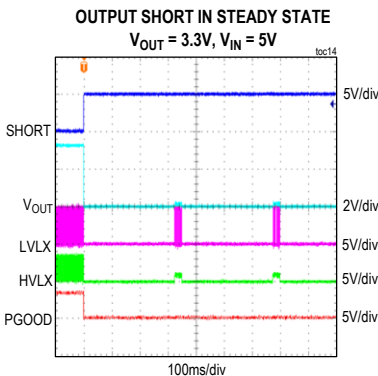
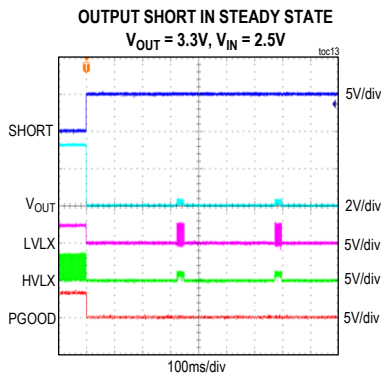
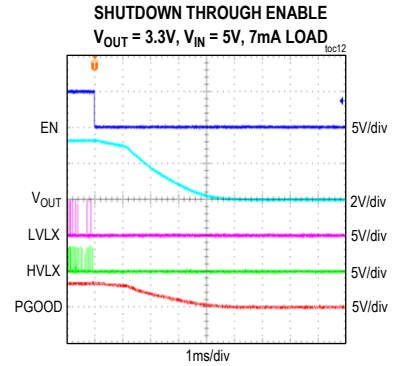
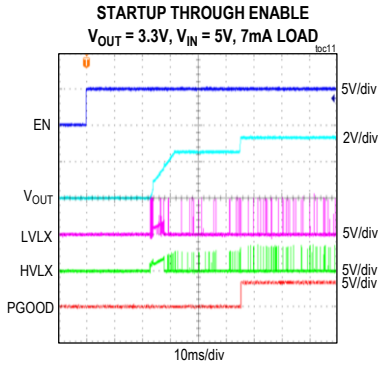
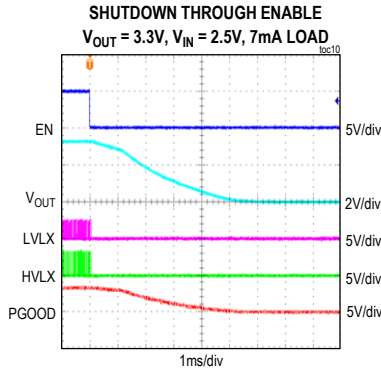

## Typical Performance Characteristics

$T_A = 25^\circ\text{C}$ , all measurements are in reference to [MAXM20344 Evaluation Board Schematic](#), unless otherwise noted.

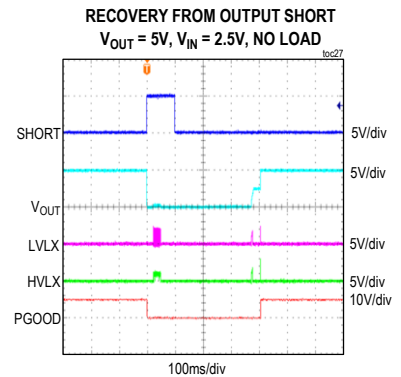
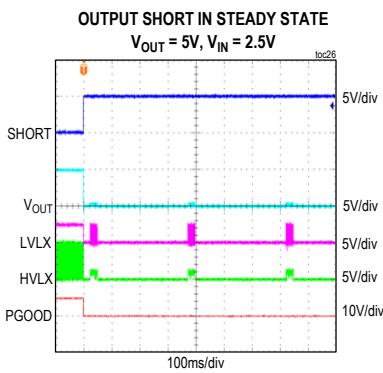
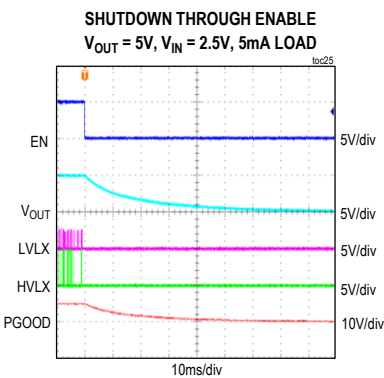
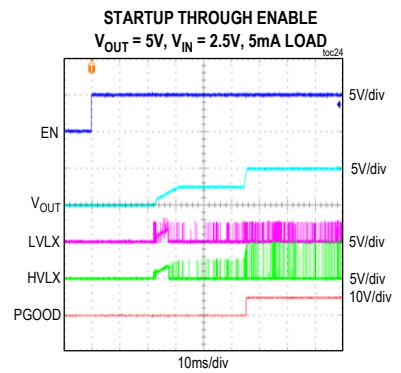
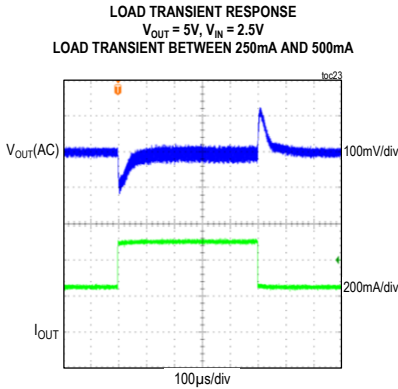
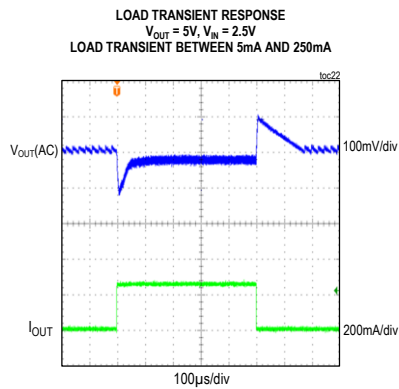
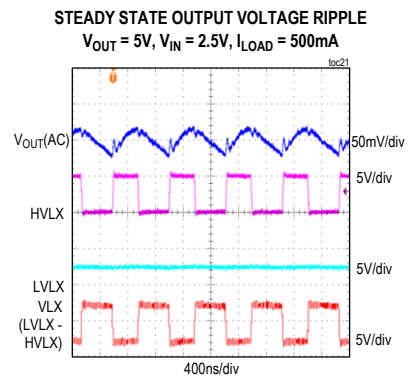
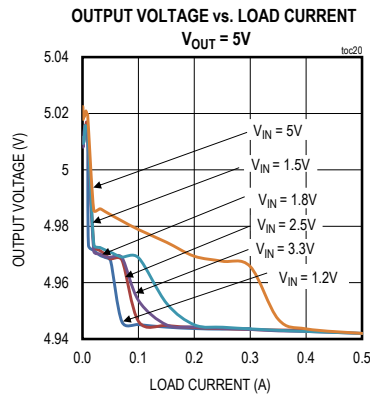
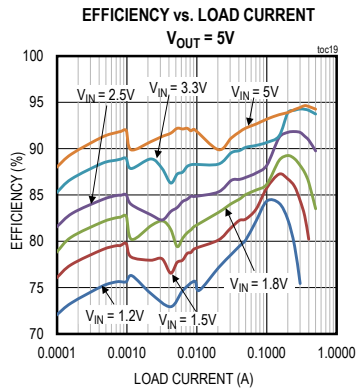

## Detailed Description

The MAXM20343/MAXM20344 evaluation boards are designed to demonstrate the salient features of the MAXM20343/MAXM20344 power modules. The evaluation boards consist of typical application circuits of two different modules. Each of these circuits are electrically isolated from each other and hosted on the same PCB. Each of the modules can be evaluated by powering them from their respective input pins. Individual module settings can be adjusted to evaluate their performance under different operating conditions.

### Enable (EN)

The evaluation board offers jumpers (JU101, JU201) to enable or disable the output. When a jumper is installed across pins 1–2, the output of the corresponding module is enabled. When a jumper is installed across pins 2–3, the output of the corresponding modules is disabled. See [Table 1](#) for the EN jumper settings. When the modules are required to work below the 1.4V input voltage, the EN pin must be externally powered up to 1.4V or greater to enable part operation.

**Table 1. EN/UVLO Jumper Description (JU101 and JU201)**

SHUNT POSITION	EN PIN	OUTPUT
1-2*	Connected to $V_{IN}$	Enabled when input voltage is above 1.4V
2-3	Connected to AGND	Disabled
Not installed	Connected to an external voltage through the EN board edge connection	Enabled when EN pin voltage is above 1.4V

\*Default Position

### Adjusting Output Voltage

The MAXM20343/MAXM20344 modules support a 2.5V to 5.5V adjustable output voltage range. The MAXM20343 evaluation board output voltage is programmed to 3.3V, and the MAXM20344 evaluation board output voltage is programmed to 5V. The output voltage is programmed using the output voltage selector resistor (R101/R201). To program the output to a different voltage, use the recommended resistor values given in Table 5 of the MAXM20343/MAXM20344 data sheet. For a 3.3V output, the resistor R101 is chosen to be 150k $\Omega$ . For a 5V output, the resistor R201 is chosen to be 6.65k $\Omega$ .

### Output Capacitor Selection

The output capacitors (C112, C212) serve to absorb the current peaks delivered from the switching power converter and reduce switching frequency ripple on the output voltages. X7R ceramic output capacitors are preferred due to their stability over temperature in industrial applications. 22 $\mu$ F/6.3V X7R ceramic capacitors are installed as output capacitors on the evaluation board.

### Input Capacitor Selection

The input capacitors (C103, C203) serve to reduce the current peaks drawn from the input power supply and reduce switching frequency ripple at the input. The input capacitance must be greater than or equal to the value given in Table 6 of the MAXM20343/MAXM20344 data sheet. Input capacitors (C106, C206) are chosen to be 10 $\mu$ F/6.3V.

### Hot Plug-In and Long Input Cables

The MAXM20343/MAXM20344 evaluation board PCBs provide optional electrolytic capacitors (C104, C204) to dampen input voltage peaks and oscillations that may arise during hot plug-in and/or due to long input cables. These capacitors limit the peak voltage at the input of the power modules when the evaluation boards are powered directly from a precharged capacitive source or an industrial backplane PCB. Long input cables between the input power source and the evaluation board circuit can cause input-voltage oscillations due to the inductance of the cables. The equivalent series resistance (ESR) of the electrolytic capacitor helps damp out the oscillations caused by long input cables. Further, 0.1 $\mu$ F ceramic capacitors placed near the input of the board help in attenuating high-frequency noise.

**Ordering Information**

<b>PART</b>	<b>TYPE</b>
MAXM20343EVKIT#	Evaluation Board
MAXM20344EVKIT#	Evaluation Board

#Denotes RoHS-compliance.

**Component Suppliers**

<b>SUPPLIER</b>	<b>WEBSITE</b>
Murata Americas	<a href="http://www.murata.com">www.murata.com</a>
Panasonic	<a href="http://www.panasonic.com">www.panasonic.com</a>

## MAXM20342/MAXM20344 Evaluation Board Bill of Materials

## MAXM20343 Evaluation Board

ITEM	QTY	REFERENCE	PART DESCRIPTION	MANUFACTURER, PART NUMBER
1	4	C101, C107, C111, C114	Ceramic Capacitor, 0.1 $\mu$ F, 10%, 16V, X7R, 0402	MURATA, GRM155R71C104KA88
2	1	C104	Aluminium Electrolytic Capacitor, 10 $\mu$ F, 20%, 35V	PANASONIC, EEH-ZC1V100
3	1	C106	Ceramic Capacitor, 10 $\mu$ F, 10%, 6.3V, X7R, 0805	MURATA, GRM21BR70J106K
4	2	C108, C110	Ceramic Capacitor, 220pF, 10%, 50V, X7R, 0402	MURATA, GRM155R71H221KA01
5	1	C109	Ceramic Capacitor, 2.2 $\mu$ F, 10%, 10V, X7R, 0603	MURATA, GRM188R71A225KE15
6	1	C112	Ceramic Capacitor, 22 $\mu$ F, 20%, 6.3V, X7R, 0805	MURATA, GRM21BZ70J226ME44
7	1	R101	Resistor, 150k $\Omega$ , 1%, 0402	N/A
8	2	R102, R103	Resistor, 100k $\Omega$ , 1%, 0402	N/A
9	1	U101	MAXM20343AMP+	ADI, MAXM20343AMP+
10	1	C102	OPTIONAL: Ceramic Capacitor, 0.47 $\mu$ F, 10%, 10V, X7R, 0603	MURATA, GRM188R71A474KA61
11	1	C105	OPTIONAL: Ceramic Capacitor, 10 $\mu$ F, 10%, 6.3V, X7R, 0805	MURATA, GRM21BR70J106K
12	1	C113	OPTIONAL: Ceramic Capacitor, 220pF, 10%, 50V, X7R, 0402	MURATA, GRM155R71H221KA01
13	1	L101	OPTIONAL: Inductor, 1.5 $\mu$ H, 20%, 2.1A, 0806	MURATA, DFE201610E-1R5M=P2
14	1	C103	OPTIONAL: Package Outline 0805	N/A

## MAXM20344 Evaluation Board

ITEM	QTY	REFERENCE	DESCRIPTION	MANUFACTURER, PART NUMBER
1	4	C201, C207, C211, C214	Ceramic Capacitor, 0.1 $\mu$ F, 10%, 16V, X7R, 0402	MURATA, GRM155R71C104KA88
2	1	C204	Aluminium Electrolytic Capacitor, 10 $\mu$ F, 20%, 35V	PANASONIC, EEH-ZC1V100
3	1	C206	Ceramic Capacitor, 10 $\mu$ F, 10%, 6.3V, X7R, 0805	MURATA, GRM21BR70J106K
4	2	C208, C210	Ceramic Capacitor, 220pF, 10%, 50V, X7R, 0402	MURATA, GRM155R71H221KA01
5	1	C209	Ceramic Capacitor, 2.2 $\mu$ F, 10%, 10V, X7R, 0603	MURATA, GRM188R71A225KE15
6	1	C212	Ceramic Capacitor, 22 $\mu$ F, 20%, 6.3V, X7R, 0805	MURATA, GRM21BZ70J226ME44
7	2	R202, R203	Resistor, 100k $\Omega$ , 1%, 0402	N/A
8	1	R201	Resistor, 6.65k $\Omega$ , 1%, 0402	N/A
9	1	U201	MAXM20344AMP+	ADI, MAXM20344AMP+
10	1	C202	OPTIONAL: Ceramic Capacitor, 0.47 $\mu$ F, 10%, 10V, X7R, 0603	MURATA, GRM188R71A474KA61
11	1	C205	OPTIONAL: Ceramic Capacitor, 10 $\mu$ F, 10%, 6.3V, X7R, 0805	MURATA, GRM21BR70J106K
12	1	C213	OPTIONAL: Ceramic Capacitor, 220pF, 10%, 50V, X7R, 0402	MURATA, GRM155R71H221KA01
13	1	L201	OPTIONAL: Inductor, 1.5 $\mu$ H, 20%, 2.1A, 0806	MURATA, DFE201610E-1R5M=P2
14	1	C203	OPTIONAL: Package Outline 0805	N/A



**MAXM20343 Evaluation Board Schematic**

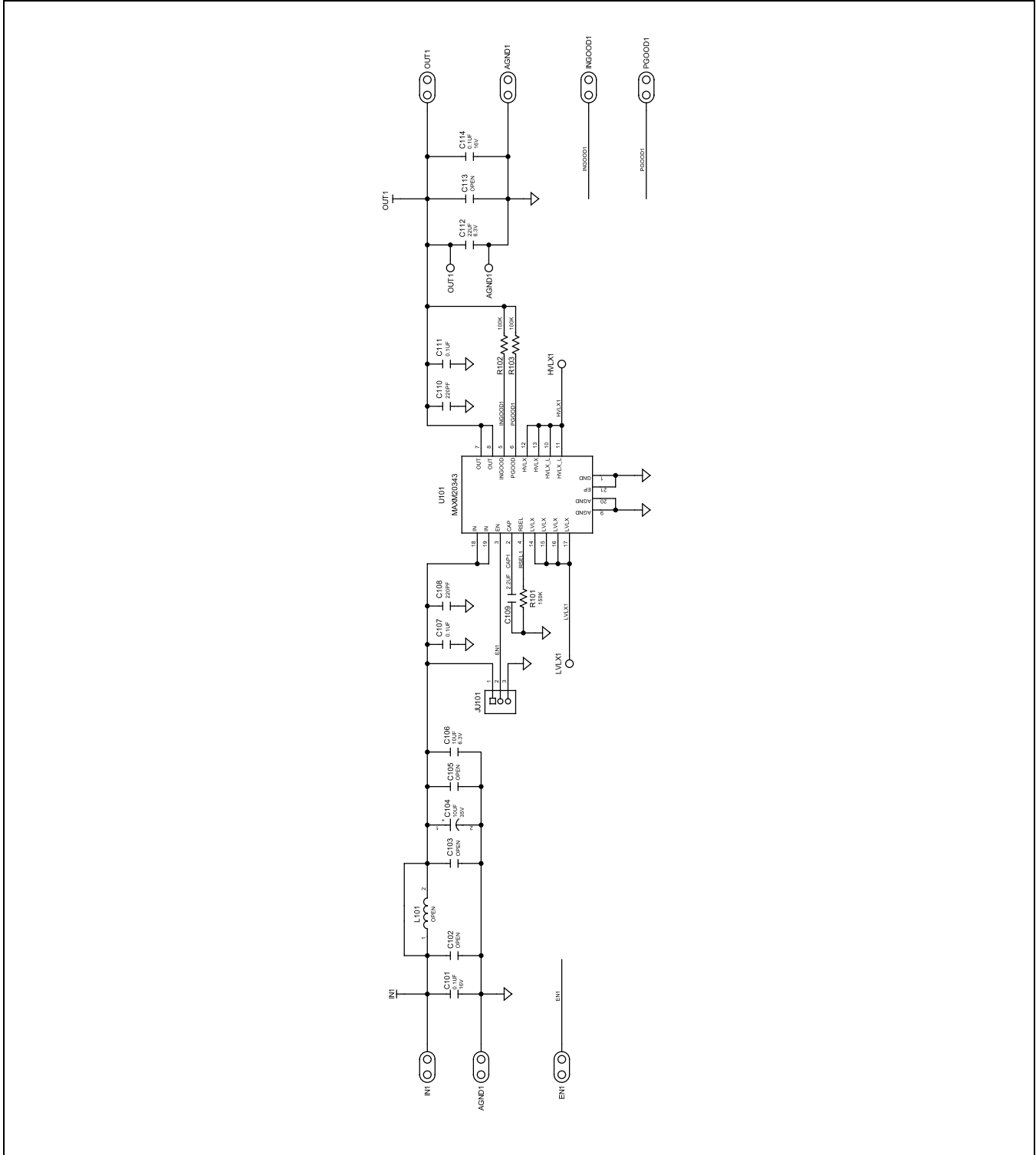

MAXM20344 Evaluation Board Schematic

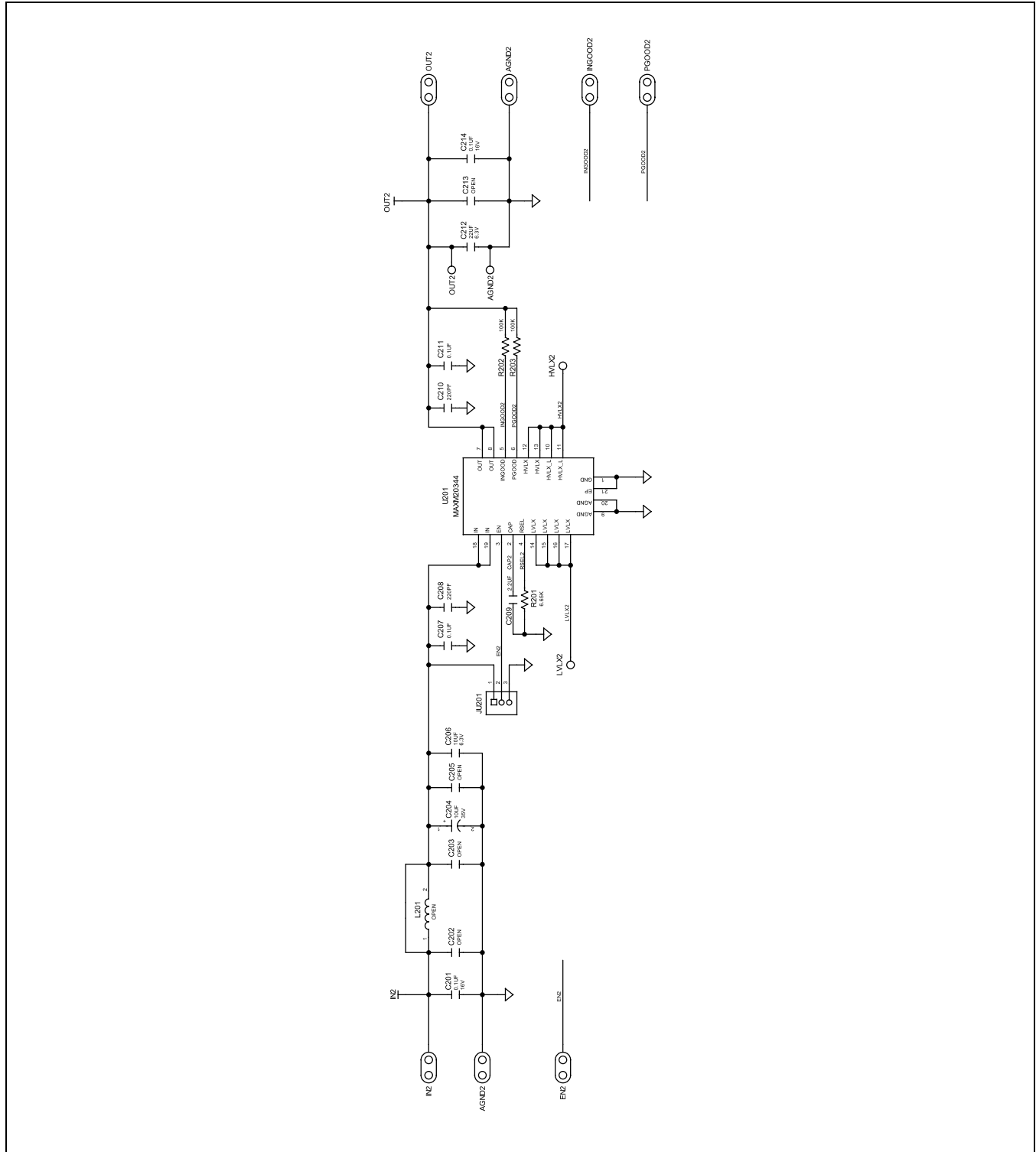

## MAXM20343/MAXM20344 Evaluation Board PCB Layout

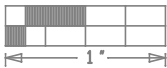
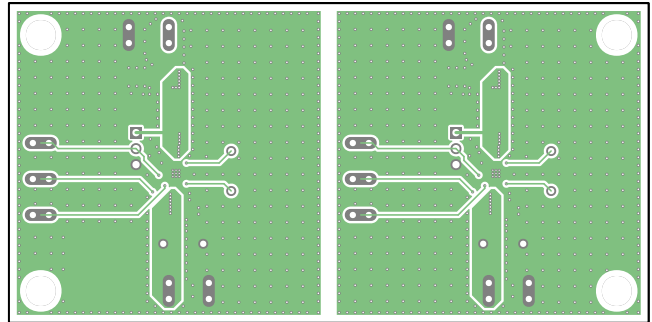
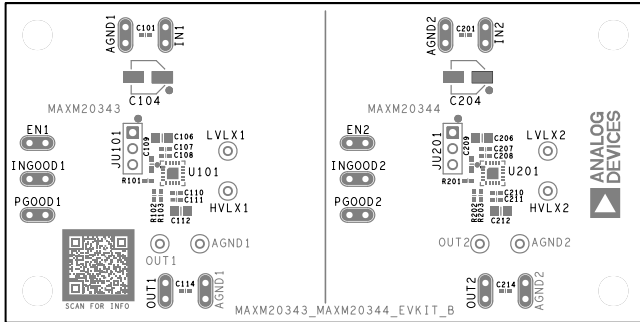

MAXM20343/MAXM20344 EV Kits—Top Silkscreen

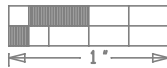

MAXM20343/MAXM20344 EV Kits—Layer 3

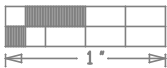
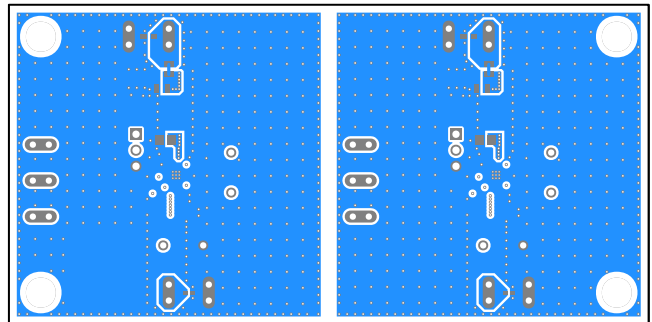
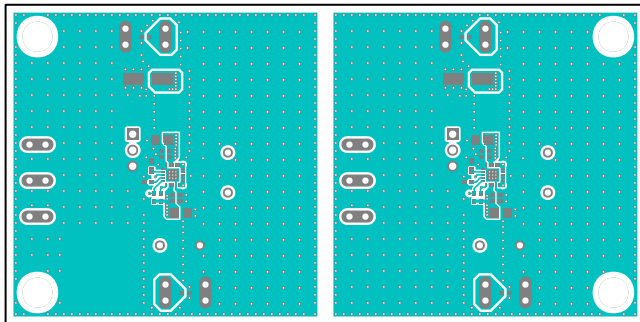

MAXM20343/MAXM20344 EV Kits—Layer 1

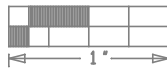

MAXM20343/MAXM20344 EV Kits—Layer 4

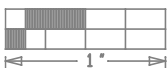
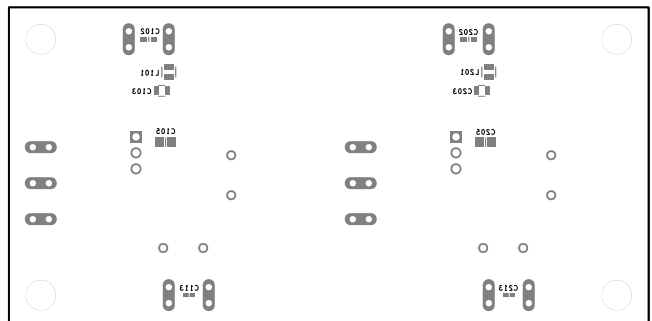
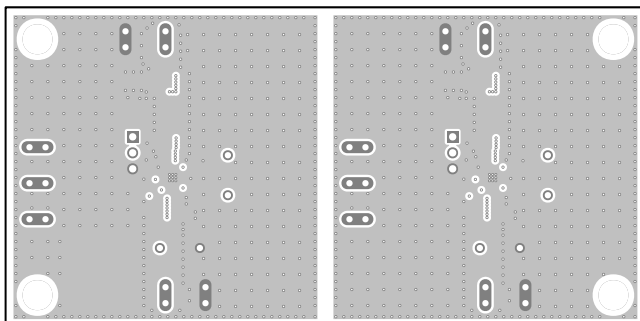

MAXM20343/MAXM20344 EV Kits—Layer 2

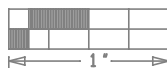

MAXM20343/MAXM20344 EV Kits—Bottom Silkscreen

### Revision History

REVISION NUMBER	REVISION DATE	DESCRIPTION	PAGES CHANGED
0	7/24	Initial release	—

## Notes

ASSUMED BY ANALOG DEVICES FOR ITS USE, NOR FOR ANY INFRINGEMENTS OF PATENTS OR OTHER RIGHTS OF THIRD PARTIES THAT MAY RESULT FROM ITS USE. SPECIFICATIONS ARE SUBJECT TO CHANGE WITHOUT NOTICE. NO LICENCE, EITHER EXPRESSED OR IMPLIED, IS GRANTED UNDER ANY ADI PATENT RIGHT, COPYRIGHT, MASK WORK RIGHT, OR ANY OTHER ADI INTELLECTUAL PROPERTY RIGHT RELATING TO ANY COMBINATION, MACHINE, OR PROCESS WHICH ADI PRODUCTS ALL INFORMATION CONTAINED HEREIN IS PROVIDED "AS IS" WITHOUT REPRESENTATION OR WARRANTY. NO RESPONSIBILITY IS OR SERVICES ARE USED. TRADEMARKS AND REGISTERED TRADEMARKS ARE THE PROPERTY OF THEIR RESPECTIVE OWNERS.