

General Description

The DC3107A evaluation board features the [LTM[®]4640](#) μ Module[®] (micromodule) regulator, a high performance, and high-efficiency step-down regulator. The LTM4640 is a complete DC-to-DC point-of-load (POL) regulator in a thermally enhanced 6.25mm \times 6.25mm \times 5.17mm BGA package. The LTM4640 has an operating input voltage range of 3.1V to 20V and provides an output current of up to 20A. The output voltage is programmable from 0.6V to 3.3V and can be remotely sensed. The stacked inductor design improves thermal dissipation and significantly reduces the package area. Output voltage tracking is available through the TRACK/SS pin for supply rail sequencing. External clock synchronization is available through the SYNC/MODE pin. For high efficiency at low load currents, select discontinuous-conduction mode (DCM) operation using the MODE jumper (JP7) in less noise-sensitive applications. Refer to the LTM4640 data sheet and read this user guide before working on or modifying the DC3107A evaluation board.

Evaluation Board Photo

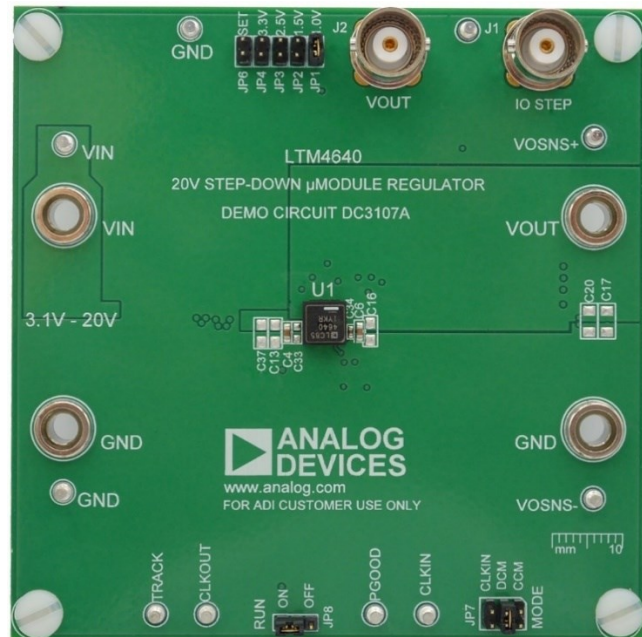

Figure 1. DC3107A Evaluation Board (Part Marking Is either Ink Mark or Laser Mark)

Features and Benefits

- Current Mode Control, Fast Transient Response
- External Frequency Synchronization
- Differential Remote Sensing

DC3107A Evaluation Board

FILE	DESCRIPTION
DC3107A	Design files

[Ordering Information](#) appears at end of this user guide.

Performance Summary

Specifications are at $T_A = 25^\circ\text{C}$

PARAMETER	CONDITIONS	MIN	TYP	MAX	UNITS
Input voltage range		3.1		20	V
Output voltage, V_{OUT}	Jumper selection on JP1.	0.98	1.0	1.02	V
Output voltage, V_{OUT}	Jumper selection on JP2.	1.47	1.5	1.53	V
Output voltage, V_{OUT}	Jumper selection on JP3.	2.45	2.5	2.55	V
Output voltage, V_{OUT}	Jumper selection on JP4.	3.23	3.3	3.37	V
Maximum continuous output current	Derating is necessary for certain operating conditions. (Refer to the <i>LTM4640 data sheet</i> for more details).		20		A
Default operating frequency			600		kHz
Efficiency	$V_{IN} = 12\text{V}$, $V_{OUT} = 1\text{V}$, $I_{OUT} = 20\text{A}$.		83.5		%

Quick Start

Required Equipment

- Power Supply
- Electronic Load
- Two Digital Multimeters (DMMs)

Procedure

The DC3107A evaluation board is an easy way to evaluate the performance of the LTM4640. See [Figure 2](#) for test setup connections and use the following procedure.

1. With the power off, place the jumpers in the following positions:

JP8	JP7	JP1 TO JP6
RUN	MODE	V_{OUT} select
ON	Continuous-conduction mode (CCM)	1V

2. With the power off, connect the input voltage supply, electronic load, and DMMs, as shown in [Figure 2](#). Preset the load current to 0A.
3. Turn on the input power and adjust the voltage supply between 3.1V and 20V. Ensure the input voltage does not exceed 20V. Check that the output voltage measures $1\text{V} \pm 2\%$.
4. Once the proper output voltage is established, adjust the load current in the 0A to 20A range and observe the load regulation, efficiency, and other parameters. Measure the output voltage ripple across the output capacitor with a Bayonet Neill–Concelman (BNC) cable and the oscilloscope from J2.
5. Place the MODE pin jumper (JP7) in the DCM position to observe increased light load efficiency.
6. For optional load transient testing, an onboard transient circuit is provided to measure transient response. Place a positive pulse signal between the IO_STEP_CLK (E10) pin and the GND pin. The pulse amplitude sets the load step current amplitude. Keep the pulse width short (<1ms) and the pulse duty cycle low (<15%) to limit the thermal stress on the load transient circuit. Monitor the load step with a BNC connected to J1 (5mV/A).

Notes

When measuring the output or input voltage ripple, do not use the long ground lead on the oscilloscope probe. See [Figure 3](#) for the proper scope probe technique. Short, stiff leads need to be soldered to the (+) and (-) terminals of an output capacitor. The probe's ground ring needs to touch the (-) lead, and the probe tip needs to touch the (+) lead.

For applications that require a small output voltage ripple, add a shunt through the tree-terminal capacitors on the output at C41 and C42.

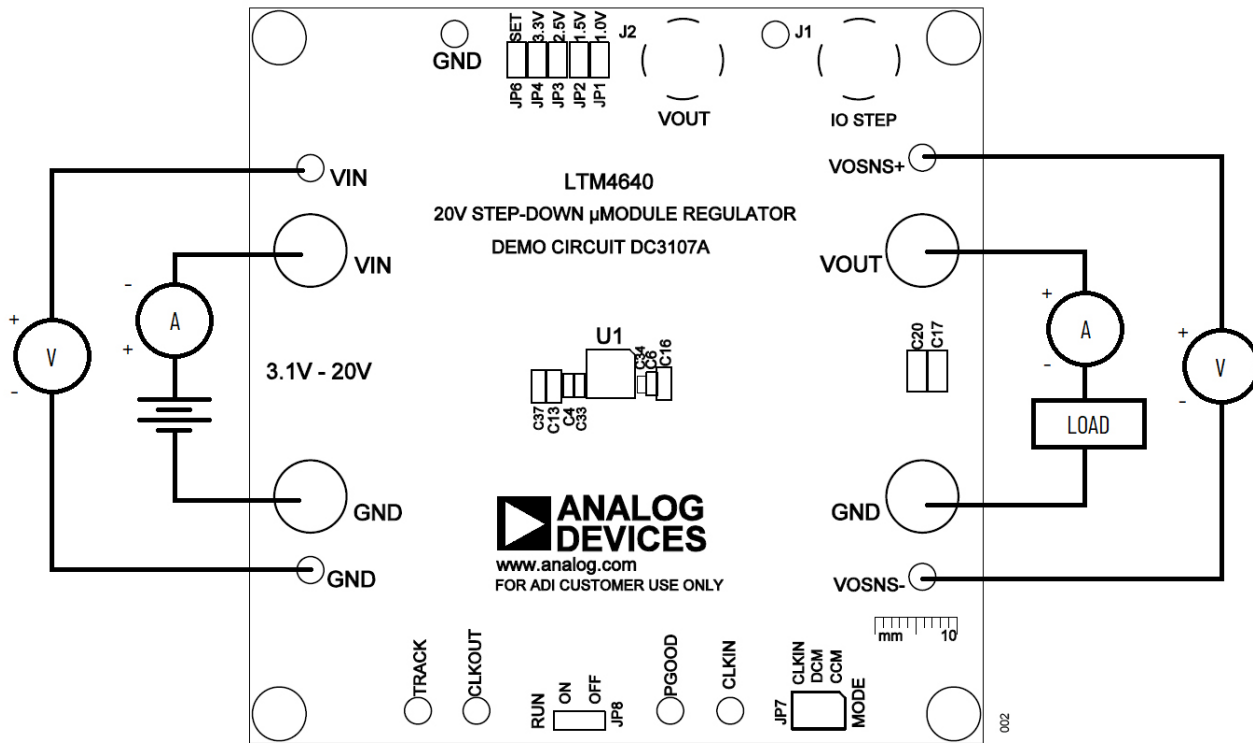

Figure 2. Test Setup of DC3107A Evaluation Board

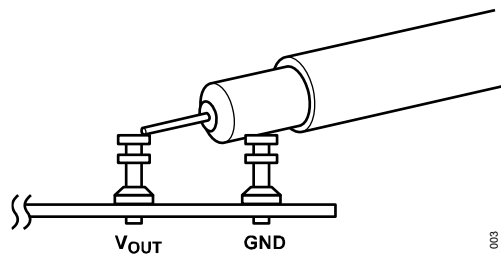
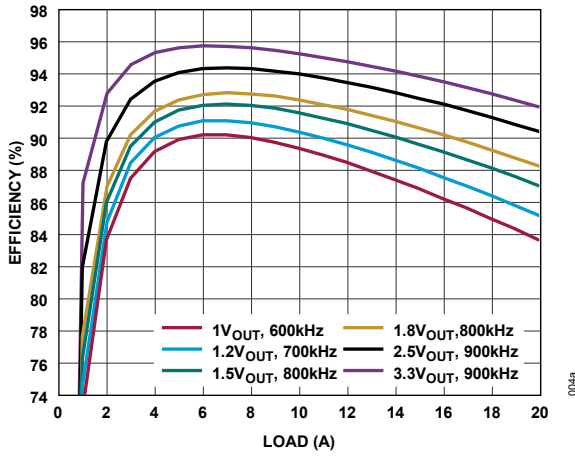
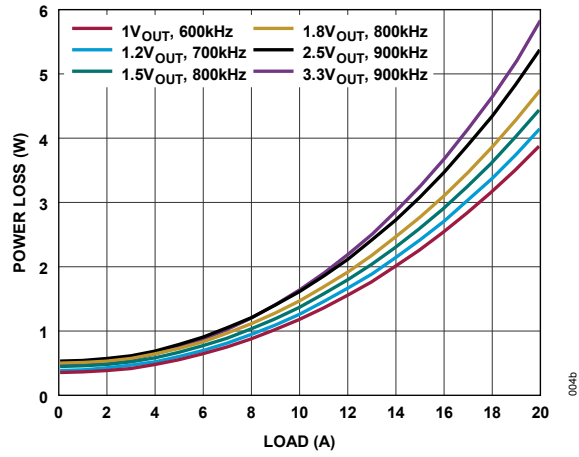

Figure 3. Measuring Output Voltage Ripple

Typical Performance Characteristics



Efficiency



Power Loss

Figure 4. Measured Supply at $V_{IN} = 5V$

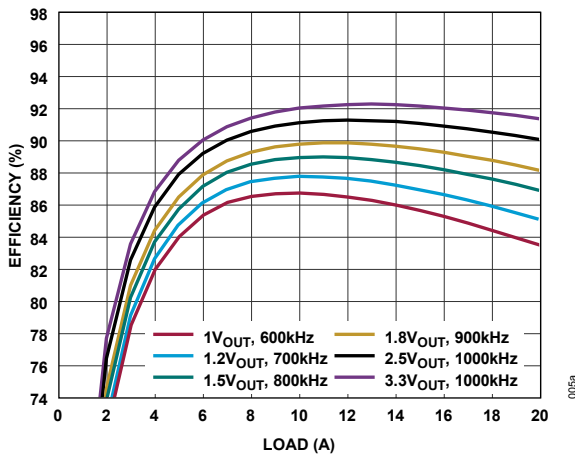

Efficiency

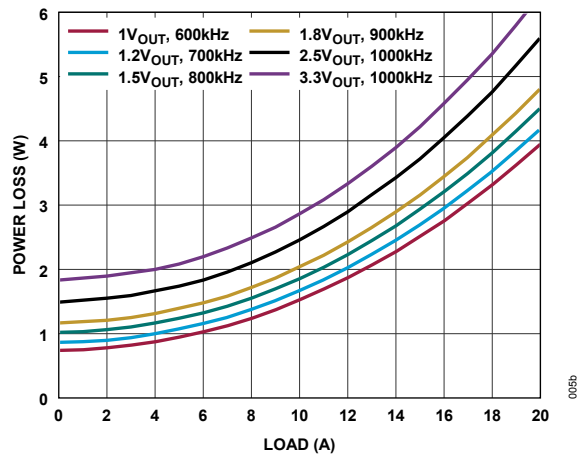

Power Loss

Figure 5. Measured Supply at $V_{IN} = 12V$

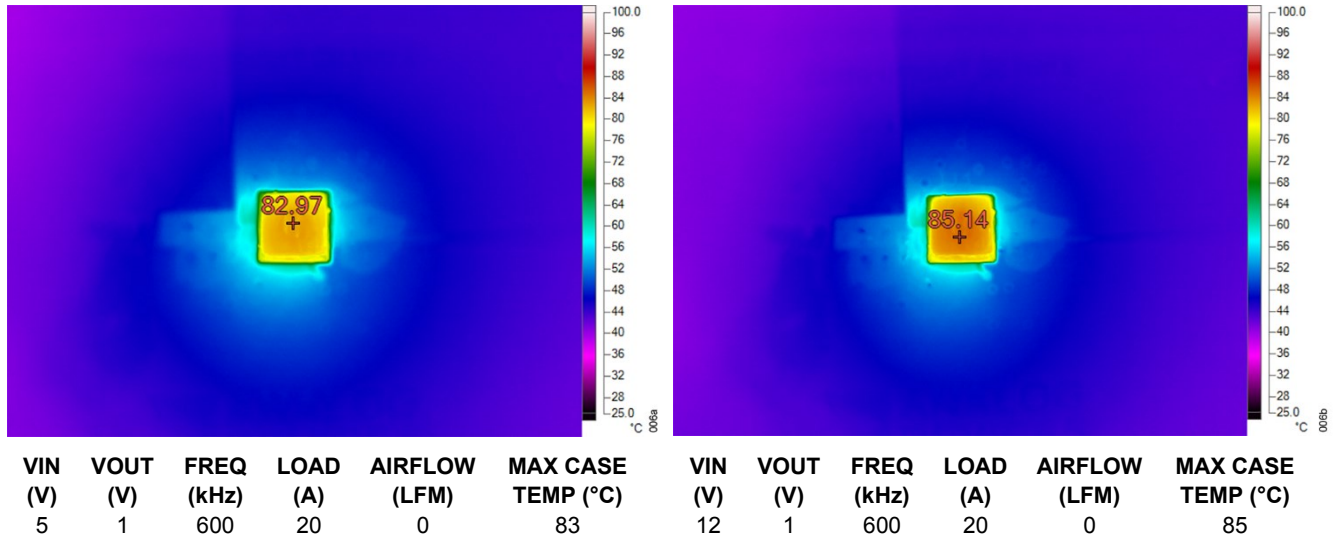

Figure 6. Measured Thermal Captures Without Forced Airflow

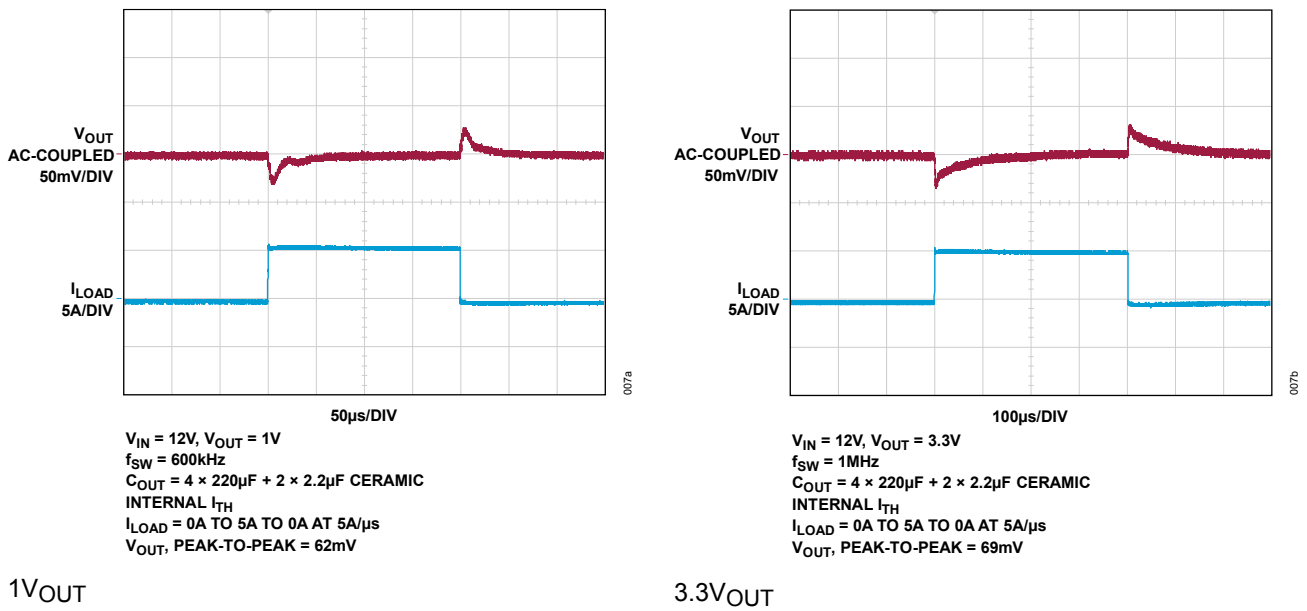
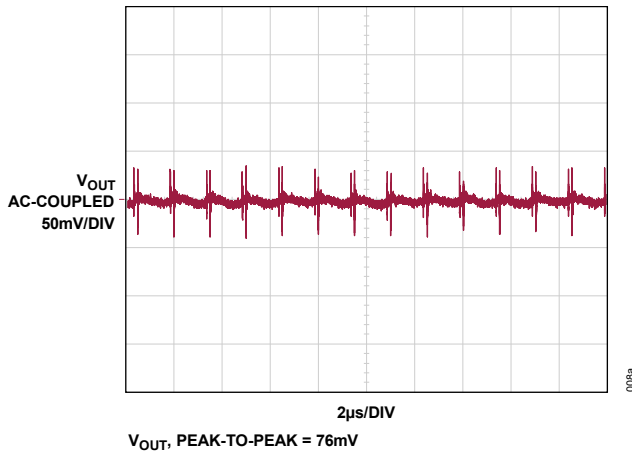
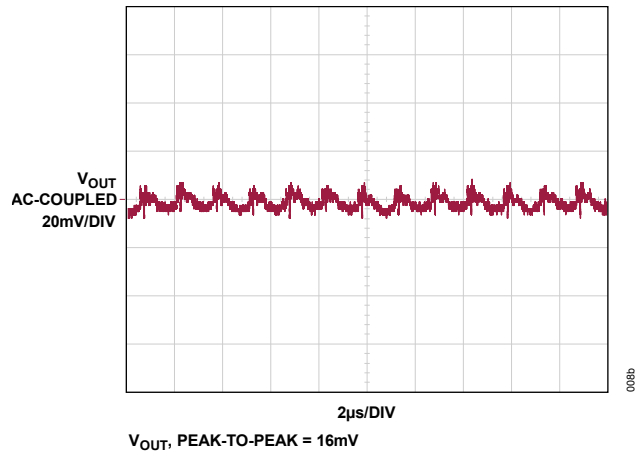

Figure 7. Load Transient Response Waveforms, 12V_{IN}



(a) 1V_{OUT}, 600kHz, Full Bandwidth at 500MHz



(b) 1V_{OUT}, 600kHz, 20MHz Bandwidth

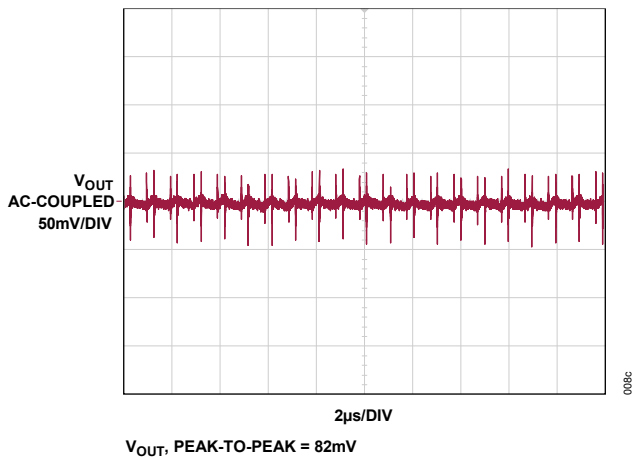

(c) 3.3V_{OUT}, 1MHz, Full Bandwidth at 500MHz

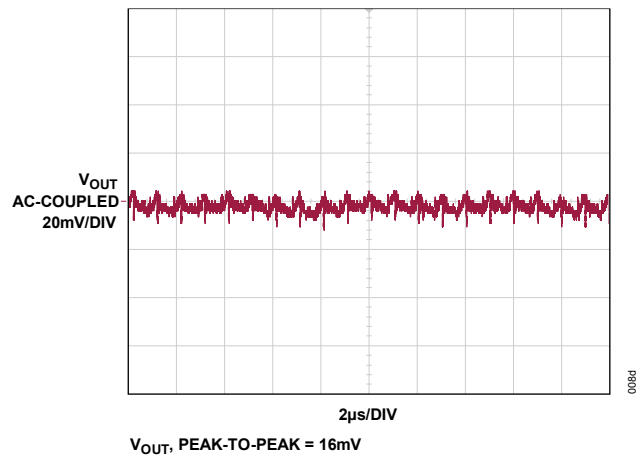

(d) 3.3V_{OUT}, 1MHz, 20MHz Bandwidth

Figure 8. Tested V_{OUT} AC-Ripple at 12V_{IN}, I_{OUT} = 15A, V_{OUT} Ripple is Tested Across C12

DC3107A Evaluation Board Bill of Materials

ITEM	QTY	REFERENCE	PART DESCRIPTION	MANUFACTURER/PART NUMBER
Required Evaluation Board Components				
1	3	C1, C6, C31	CAP., 2.2 μ F, X7R, 10V, 20%, 0603	TDK, C1608X7R1A225M080AC
2	3	C2, C3, C38	CAP., 22 μ F, X5R, 25V, 10%, 1206	AVX, 12063D226KAT2A
3	1	C4	CAP., 1 μ F, X7R, 25V, 10%, 0603	TAIYO YUDEN, TMK107B7105KA-T
4	4	C5, C11, C12, C30	CAP., 220 μ F, X5R, 6.3V, 20%, 1206	MURATA, GRM31CR60J227ME11L
5	1	C7	CAP., 0.1 μ F, X7R, 25V, 10%, 0603	AVX, 06033C104KAT2A
6	1	C8	CAP., 100pF, X7R, 25V, 5%, 0603	AVX, 06033C101JAT2A
7	1	C10	CAP., 220 μ F, ALUM HYB, 35V, 20%, 10mm \times 12.5mm, RADIAL, HVH SERIES	SUN ELECTRONIC INDUSTRIES CORP., 35HVH220M+P
8	1	C18	CAP., 4.7 μ F, X7R, 10V, 10%, 0603	MURATA, GRM188Z71A475KE15D
9	1	C29	CAP., 0.022 μ F, X7R, 50V, 10%, 0603	KEMET, C0603C223K5RAC7867
10	1	C34	CAP., 1 μ F, X7R, 6.3V, 10%, 0402	MURATA, GRM155R70J105KA12D
11	1	C41	CAP., FEED THRU 0.022 μ F, 20%, 16V, 1A 50m Ω 0603 (1608 METRIC), 3-PC PAD	MURATA, NFM18CC223R1C3D
12	1	C42	CAP., 27 μ F, FEED THRU, 6.3V, 20%, 1206, 3-TERM, 5m Ω DCR, 6A	MURATA, NFM31PC276B0J3L
13	1	L2	IND., 0.08 μ H, PWR, 20%, 21.4A, 1.8m Ω , 4mm \times 4mm, AEC-Q200	COILCRAFT, XEL4020-800MEC
14	1	Q1	XSTR., MOSFET, N-CH, 40V, 14A, DPAK (TO-252)	VISHAY, SUD50N04-8M8P-4GE3
15	1	R3	RES., 10k Ω , 1%, 1/10W, 0603, AEC-Q200	VISHAY, CRCW060310K0FKEA
16	1	R4	RES., 15k Ω , 5%, 1/10W, 0603	YAGEO, RC0603JR-0715KL
17	1	R6	RES., 6.65k Ω , 1%, 1/10W, 0603	NIC, NRC06F6651TRF
18	1	R7	RES., 150k Ω , 5%, 1/10W, 0603, AEC-Q200	PANASONIC, ERJ3GEYJ154V
19	2	R8, R16	RES., 100k Ω , 1%, 1/10W, 0603	STACKPOLE ELECTRONICS, INC., RMCF0603FG100K
20	2	R9, R10	RES., 0 Ω , 5%, 1/16W, 0402	ROHM, MCR01MZPJ000
21	1	R14	RES., 2.21k Ω , 1%, 1/10W, 0603	VISHAY, CRCW06032K21FKEA
22	1	R15	RES., 3.09k Ω , 1%, 1/10W, 0603	NIC, NRC06F3091TRF
23	1	R17	RES., 0 Ω , 1/10W, 0603, AEC-Q200	VISHAY, CRCW06030000Z0EA
24	1	RS2	RES., 0.005 Ω , 1%, 1W, 2512, METAL, SENSE, AEC-Q200	VISHAY, WSL25125L000FEA
25	1	U1	IC, STEP-DOWN μ Module REG., BGA-49	ANALOG DEVICES, LTM4640EY#PBF

ITEM	QTY	REFERENCE	PART DESCRIPTION	MANUFACTURER/PART NUMBER
Additional Evaluation Board Circuit Components				
1	0	C13, C16, C22-C24, C37	CAP., OPTION, 0805	
2	0	C9, C15, C19, C33, C36, C43, C44	CAP., OPTION, 0603	
3	0	C17, C20, C21	CAP., OPTION, 1206	
4	0	C25-C28	CAP., OPTION, 1210	
5	0	C35	CAP., OPTION, 0402	
6	0	C39	CAP., FEED THRU 0.1 μ F, 20%, 25V, 2A, 30m Ω 805 (2012 METRIC), 3-PC PAD	MURATA, NFM21PC104R1E3D
7	0	C40	CAP., FEED THRU 0.1 μ F, 20%, 100V, 10A, 1.5m Ω 1206 (3216 METRIC), 3-PC PAD	TDK, YFF31HC2A104MT000N
8	0	L1	IND., OPTION, 1812	
9	0	R1, R2, R5, R11-R13, R19, R20	RES., OPTION, 0603	
10	0	R18, R21-R23	RES., OPTION, 0402	
Hardware For Evaluation Board Only				
1	10	E1, E3, E5, E6, E8-E12, E14	TEST POINT, TURRET, 0.064" MTG. HOLE, PCB 0.062" THK	MILL-MAX, 2308-2-00-80-00-00-07-0
2	4	E2, E4, E7, E13	CONN., BANANA JACK, FEMALE, THT, NON-INSULATED, SWAGE, 0.218"	KEYSTONE, 575-4
3	2	J1, J2	CONN., RF, BNC, RCPT, JACK, 5-PIN, ST, THT, 50 Ω	AMPHENOL RF, 112404
4	5	JP1-JP4, JP6	CONN., HDR, MALE, 1 \times 2, 2mm, VERT, ST, THT	SULLINS CONNECTOR SOLUTIONS, NRPN021PAEN-RC
5	1	JP7	CONN., HDR, MALE, 2 \times 3, 2mm, VERT, ST, THT	SULLINS CONNECTOR SOLUTIONS, NRPN032PAEN-RC
6	1	JP8	CONN., HDR, MALE, 1 \times 3, 2mm, VERT, ST, THT, NO SUBS. ALLOWED	SAMTEC, TMM-103-02-L-S
7	4	MP1-MP4	STANDOFF, NYLON, SNAP-ON, 0.25" (6.4mm)	KEYSTONE, 8831
8	3	XJP1, XJP7, XJP8	CONN., SHUNT, FEMALE, 2-POS, 2mm	SAMTEC, 2SN-BK-G

DC3107A Schematic

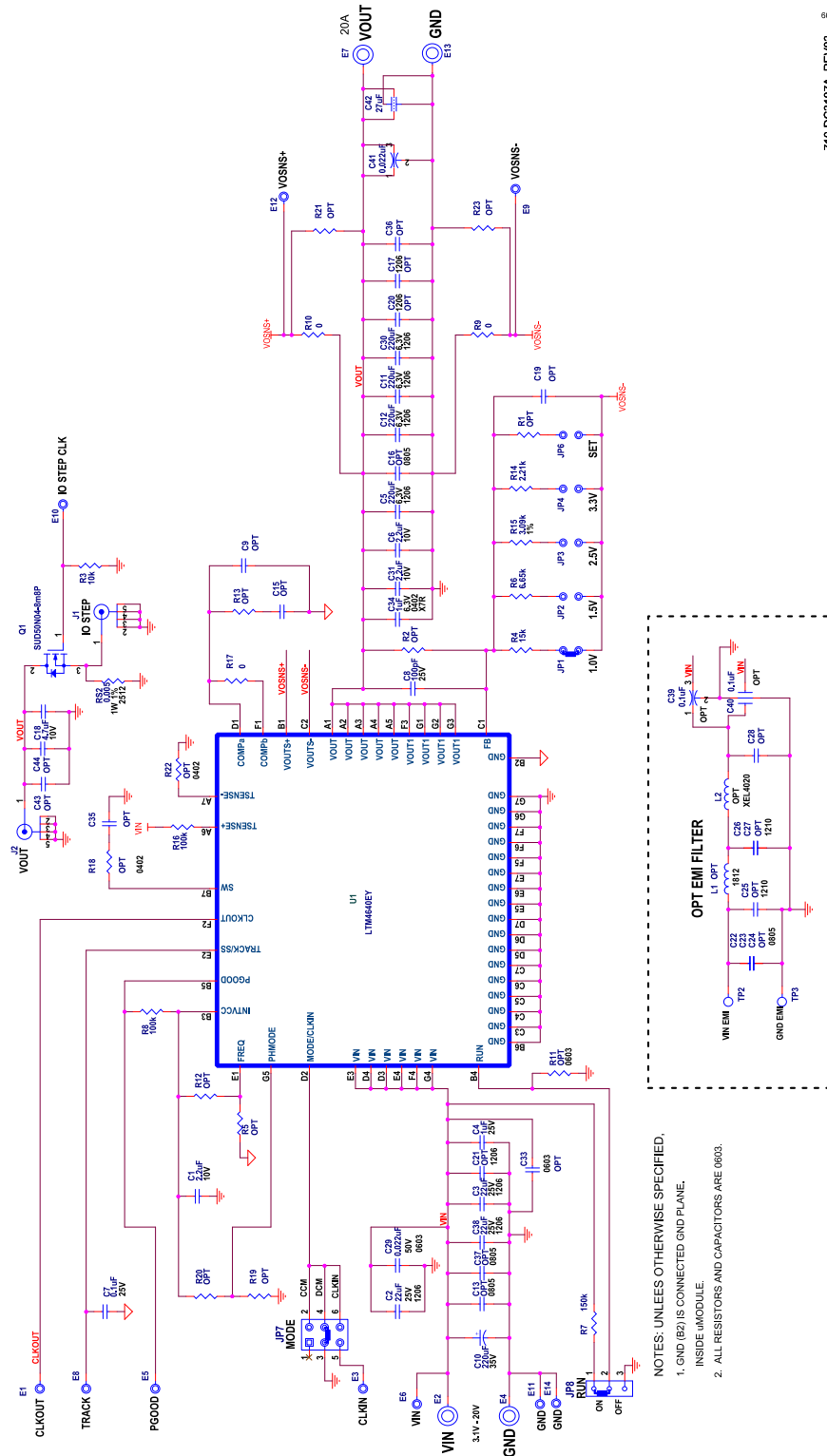

710-DC3107A_REV03

Ordering Information

PART	TYPE
DC3107A	The DC3107A evaluation board features the LTM4640 μ Module regulator.

Revision History

REVISION NUMBER	REVISION DATE	DESCRIPTION	PAGES CHANGED
0	09/24	Initial release	—

Notes

ALL INFORMATION CONTAINED HEREIN IS PROVIDED “AS IS” WITHOUT REPRESENTATION OR WARRANTY. NO RESPONSIBILITY IS ASSUMED BY ANALOG DEVICES FOR ITS USE, NOR FOR ANY INFRINGEMENTS OF PATENTS OR OTHER RIGHTS OF THIRD PARTIES THAT MAY RESULT FROM ITS USE. SPECIFICATIONS ARE SUBJECT TO CHANGE WITHOUT NOTICE. NO LICENSE, EITHER EXPRESSED OR IMPLIED, IS GRANTED UNDER ANY ADI PATENT RIGHT, COPYRIGHT, MASK WORK RIGHT, OR ANY OTHER ADI INTELLECTUAL PROPERTY RIGHT RELATING TO ANY COMBINATION, MACHINE, OR PROCESS, IN WHICH ADI PRODUCTS OR SERVICES ARE USED. TRADEMARKS AND REGISTERED TRADEMARKS ARE THE PROPERTY OF THEIR RESPECTIVE OWNERS. ALL ANALOG DEVICES PRODUCTS CONTAINED HEREIN ARE SUBJECT TO RELEASE AND AVAILABILITY.