

QUICK START GUIDE FOR DEMONSTRATION CIRCUIT 1046A HIGH EFFICIENCY 48V BUCK BOOST DC/DC SUPPLY

LTC3780EG/LTC4440ES6

DESCRIPTION

Demonstration circuit 1046A is a non-isolated, high efficiency buck-boost DC/DC supply featuring LTC®3780EG and LTC®4440ES6. The LTC3780 is a high performance 4-switch synchronous buck boost regulator and the LTC4440 is a 100V-rated FET driver. The input voltage of the demo board is designed for 36V to 72V. The output voltage is 48V. At 25°C room temperature, the maximum output current is 5A without a cooling fan and 6A with 150LFM

air flow for cooling. An optional 12V bias flyback supply using the LTC3803 is stuffed on the board to power the LTC3780 and LTC4440.

**Design files for this circuit board are available.
Call the LTC factory.**

 , LTC and LT are registered trademarks of Linear Technology Corporation.

Table 1. Performance Summary (T_A = 25°C)

PARAMETER	CONDITION	VALUE
Input Voltage	Min / Max	36V-72V
Output Voltage V _{OUT}	I _{OUT} = 0A to 6A	48V ± 2%
Maximum Output Current	V _{IN} = 36V to 72V, no fan, at room T _A =25°C	5A
	V _{IN} = 36V to 72V, 150LFM air flow, at room T _A =25°C	6A
Switching frequency	36V to 72V input, typical	300kHz
Full Load Efficiency	V _{IN} = 36V, V _{OUT} = 48V, I _{OUT} = 6A	96.8% Typical
	V _{IN} = 48V, V _{OUT} = 48V, I _{OUT} = 6A	96.6 % Typical
	V _{IN} = 72V, V _{OUT} = 48V, I _{OUT} = 6A	96.4 % Typical

QUICK START PROCEDURE

Demonstration circuit 1046A is easy to set up to evaluate the performance of the LTC3780EG. Refer to Figure 1 for proper measurement equipment setup and follow the procedure below:

NOTE: When measuring the input or output voltage ripple, care must be taken to avoid a long ground

lead on the oscilloscope probe. Measure the input or output voltage ripple by touching the probe tip directly across the V_{in} or V_{out} and GND terminals. See Figure 2 for proper scope probe technique.

QUICK START GUIDE FOR DEMONSTRATION CIRCUIT 1046A

HIGH EFFICIENCY 48V BUCK BOOST DC/DC SUPPLY

1. With power off, connect the input power supply to VIN and GND. Connect the load between VOUT, and GND. Preset the load current at 0A (minimum). Refer to Figure 1 for correct test set up. The default position of FCB jumper JP1 is CCM.
2. Turn on the input power.

NOTE: Make sure that the input voltage does not exceed 72V.

3. Check for the proper output voltage in the range of 47.0V to 49.0V. If there is no output, temporarily disconnect the load to make sure that the load is not set too high.
4. Once the proper output voltages are established, adjust the loads within the operating range and observe the output voltage regulation, ripple voltage, efficiency and other parameters.

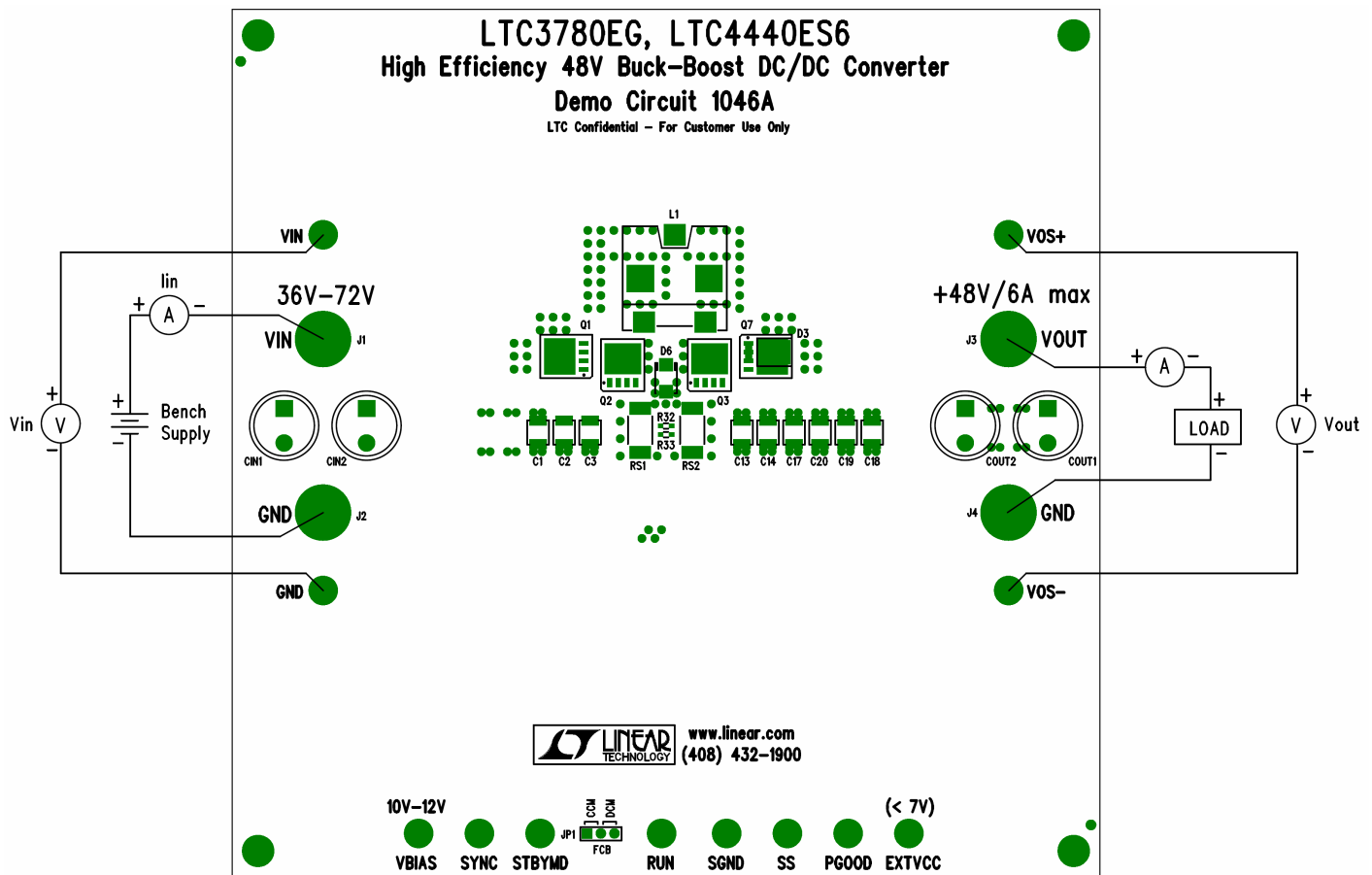

Figure 1. Proper Measurement Equipment Setup

QUICK START GUIDE FOR DEMONSTRATION CIRCUIT 1046A

HIGH EFFICIENCY 48V BUCK BOOST DC/DC SUPPLY

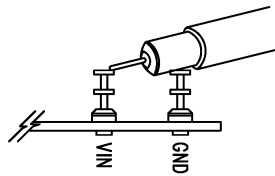

Figure 2. Measuring Input or Output Ripple

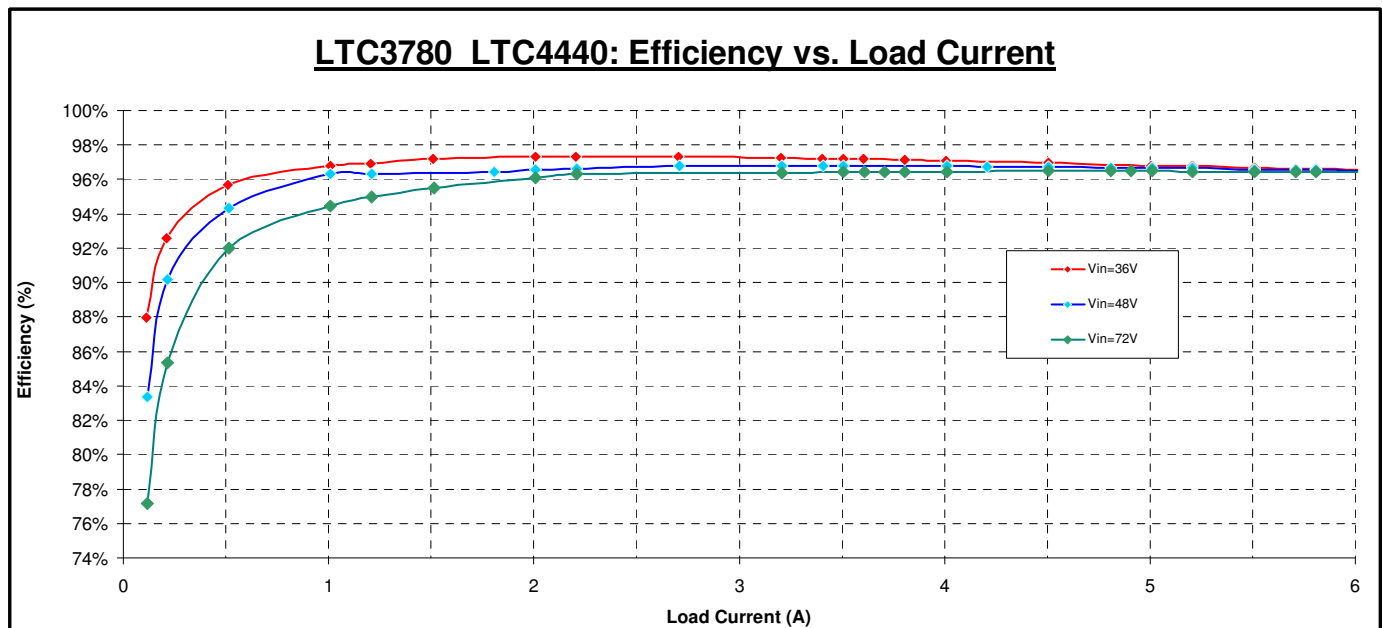
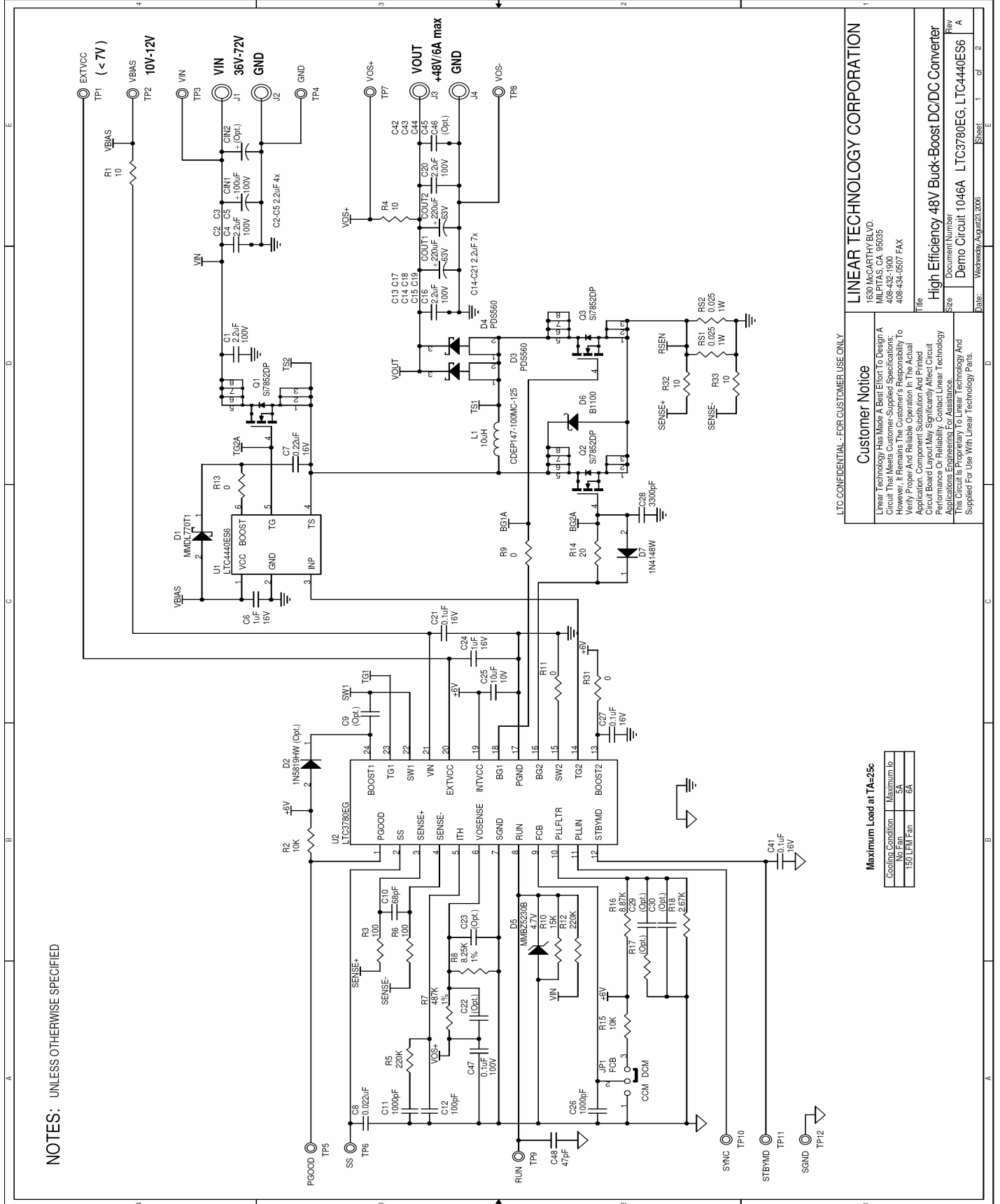

Figure 3. Typical Supply Efficiency vs Load Current at 36V, 48V and 72V input

QUICK START GUIDE FOR DEMONSTRATION CIRCUIT 1046A

HIGH EFFICIENCY 48V BUCK BOOST DC/DC SUPPLY



NOTES: UNLESS OTHERWISE SPECIFIED

Maximum Load at $T_A=25^{\circ}\text{C}$

Cooling Condition	Maximum Io
No-Fan	5A
150 LFM-Fan	6A

LTC CONFIDENTIAL - FOR CUSTOMER USE ONLY

Customer Notice

Linear Technology Has Made A Best Effort To Design A Circuit That Meets Customer-Supplied Specifications. However, It Remains The Customer's Responsibility To Verify Proper And Reliable Operation In The Actual Application. Component Substitution And Printed Circuit Board Layout May Significantly Affect Circuit Performance Or Reliability. Contact Linear Technology At custhelp@linear.com For Assistance. This Circuit Is Provided To Linear Technology And Supplied For Use With Linear Technology Parts.

LINEAR TECHNOLOGY CORPORATION

1630 MCCARTHY BLVD.
MILPITAS, CA 95035
408-432-1900
408-434-0507 FAX

Title: High Efficiency 48V Buck-Boost DC/DC Converter

Document Number: LT04440ES6
Demo Circuit: 1046A
Date: Wednesday, August 23, 2006

QUICK START GUIDE FOR DEMONSTRATION CIRCUIT 1046A

HIGH EFFICIENCY 48V BUCK BOOST DC/DC SUPPLY

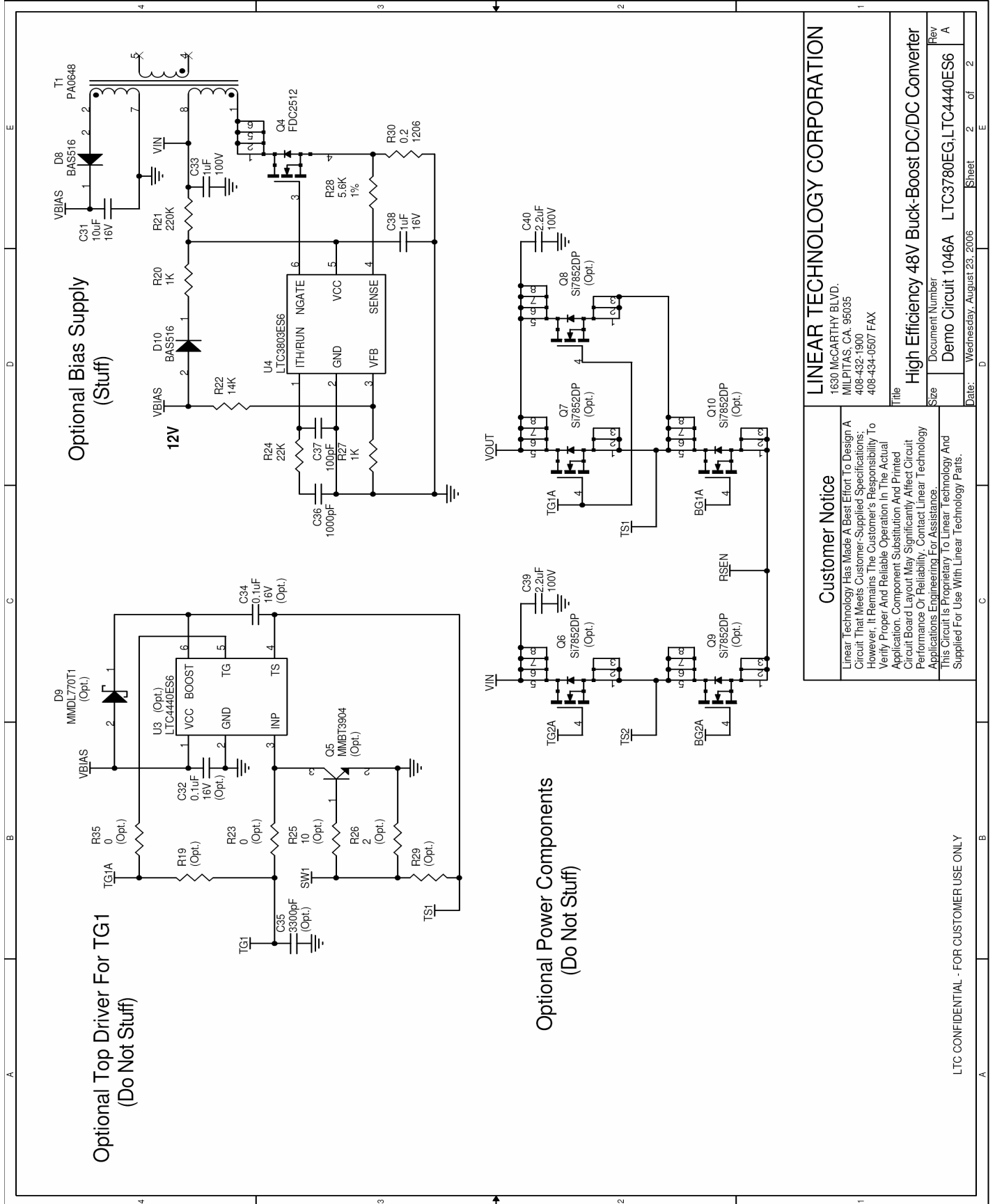

Optional Bias Supply
(Stuff)

Optional Top Driver For TG1
(Do Not Stuff)

Optional Power Components
(Do Not Stuff)

LINEAR TECHNOLOGY CORPORATION	
1630 McCARTHY BLVD. MILPITAS, CA. 95035 408-432-1900 408-434-0507 FAX	
Customer Notice	
Linear Technology Has Made A Best Effort To Design A Circuit That Meets Customer-Supplied Specifications; However, It Remains The Customer's Responsibility To Verify Proper And Reliable Operation In The Actual Application. Component Substitution And Printed Circuit Board Layout May Significantly Affect Circuit Performance Or Reliability. Contact Linear Technology Applications Engineering For Assistance.	
This Circuit Is Proprietary To Linear Technology And Supplied For Use With Linear Technology Parts.	
High Efficiency 48V Buck-Boost DC/DC Converter	
Size	Document Number
Rev	Demo Circuit 1046A
Part Number	LTC3780EG, LTC4440ES6
Date:	Wednesday, August 23, 2006
Sheet	2 of 2

LTC CONFIDENTIAL - FOR CUSTOMER USE ONLY