

TMCM-3351 Hardware Manual

Hardware Version V1.00 | Document Revision V1.01 • 2021-SEP-08

The TMCM-3351 is a three axes motor controller/driver board for 2-phase bipolar stepper motors. It is the direct successor of the TMCM-351 - mechanically and electrically compatible - with our latest generation of stepper driver and motion controller ICs supporting linear and S-shaped ramps and closed-loop operation with external ABN-encoders.

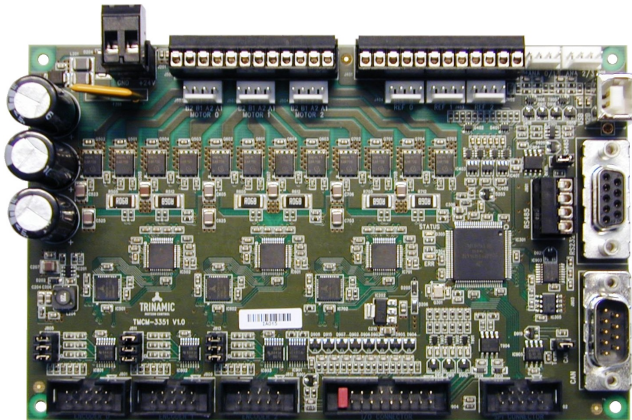

Features

- 3-axes controller/driver for 2-phase bipolar stepper motor
- Linear and S-shaped ramps and closed-loop operation with external encoder
- +11...28V DC supply voltage
- Up to 3A RMS motor current
- RS485, CAN, RS232 & USB interfaces
- multi-purpose inputs and outputs

Applications

- Laboratory Automation
- Manufacturing
- Semiconductor Handling
- Robotics
- Factory Automation
- Test & Measurement
- Life Science
- Biotechnology
- Liquid Handling

Simplified Block Diagram

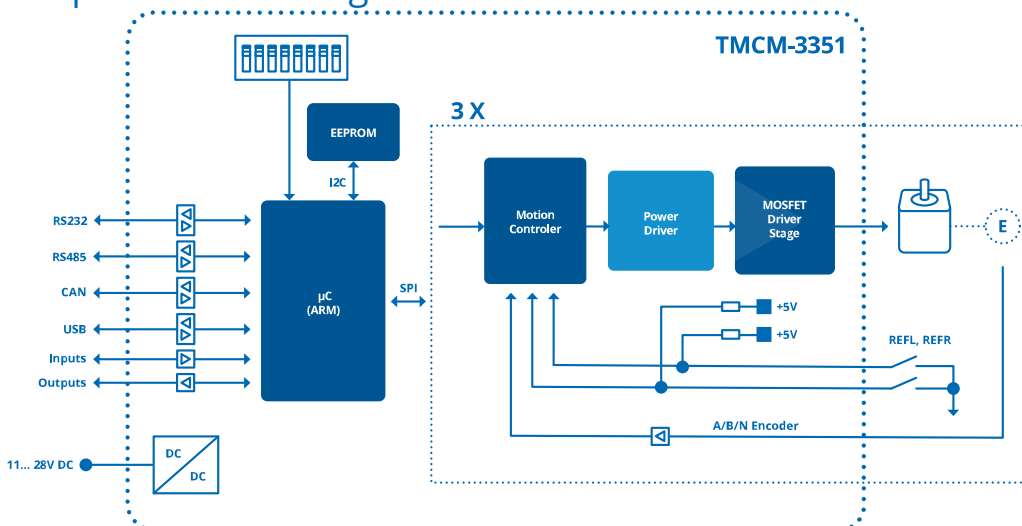

Contents

1	Features	4
2	Order Codes	5
3	Mechanical and Electrical Interfacing	6
3.1	Size of the Board	6
4	Connectors	7
4.1	Power Connector	9
4.2	Motor Connector	9
4.3	End Switch Connector	10
4.4	Analog Input Connector	11
4.5	USB Connector	11
4.6	RS232 Connector	12
4.7	CAN Connector	12
4.8	RS485 Connector	12
4.9	SPI Connector	13
4.10	I/O Connector	13
4.11	Encoder Connector	14
5	Jumper Settings	15
5.1	Encoder input termination	16
5.2	Enable all driver stages permanently	16
6	LEDs	17
7	Communication	18
7.1	RS485	18
7.2	USB	19
7.3	CAN	19
8	Motor Driver Current	21
9	Functional Description	23
10	Operational Ratings and Characteristics	24
11	Abbreviations used in this Manual	26
12	Figures Index	27
13	Tables Index	28
14	Supplemental Directives	29
14.1	Producer Information	29
14.2	Copyright	29
14.3	Trademark Designations and Symbols	29
14.4	Target User	29
14.5	Disclaimer: Life Support Systems	29
14.6	Disclaimer: Intended Use	29
14.7	Collateral Documents & Tools	30
15	Revision History	31
15.1	Hardware Revision	31



15.2 Document Revision 31



1 Features

The TMCM-3351 is a three axes stepper motor controller / driver board for 2-phase bipolar stepper motors. Linear ramps and S-shaped ramps as well as closed-loop operation with optional encoders are supported for each of the three axes. The TMCM-3351 offers a large number of general purpose digital and analog inputs and digital outputs. For communication a number of serial communication interfaces including RS485, CAN, USB and RS232 are available.

Electrical data

- Supply voltage: +24V DC (+11... +28V DC)
- Motor current: up to 3A RMS (programmable in software)

Mechanical data

- Board size: 160mm x 100mm, overall height 35mm without mating connectors
- 4 mounting holes for M3 screws

Stepper motor data

- Two phase bipolar stepper motors with up-to 3A RMS coil current
- Incremental (a/b/n) encoder (optional), differential and single ended (TTL + open-collector) encoder signals are supported

Interfaces

- 2 reference switch inputs per motor axis (6 altogether, internal pull-up resistors, +24V compatible)
- 8 general purpose inputs (+24V compatible)
- 8 general purpose outputs (open-collector, 6x 100mA, 2x 1A)
- 1 shutdown input for all three axes (enable / disable driver stage in hardware)
- 4 dedicated analog inputs (programmable 3.3V / 10V input range)
- SPI connector with three chip select signals for I/O extension (depending on firmware version)
- RS485 (2-wire), CAN, USB and RS232 serial communication interfaces

Features

- High efficient operation, low power dissipation
- integrated protection
- On the fly alteration of motor parameters (e.g. position, velocity, acceleration)
- Motion profile calculation in real time (linear and S-shaped ramps)
- Each axis individually and independently programmable
- Up to 256 microsteps per fullstep
- Closed-loop operation with external encoder

Software

- TMCL™ remote (direct mode) and standalone operation
- Fully supported by TMCL-IDE (PC based integrated development environment)
- Optional CANopen firmware



2 Order Codes

The TMCM-3351 is available with standard TMCL firmware or CANopen firmware.

TMCM-3351 Order Codes		
Order Code	Description	Size (LxWxH)
TMCM-3351-TMCL	3-axes stepper controller / driver, +24V, 3x 3A RMS, closed-loop with encoder, many GPIOs, RS485, CAN, USB and RS232 with TMCL firmware	160mm x 100mm x 35mm
TMCM-3351-CANOPEN	3-axes stepper controller / driver, +24V, 3x 3A RMS, closed-loop with encoder, many GPIOs, RS485, CAN, USB and RS232 with CANopen firmware	160mm x 100mm x 35mm

Table 1: TMCM-3351 Order Codes



3 Mechanical and Electrical Interfacing

3.1 Size of the Board

The TMC3351 three axes controller / driver board has a board size of 160mm x 100mm (standard euro board format). Four mounting holes are available for standard M3 screws - one in each corner. All four mounting holes are non-plated and isolated.

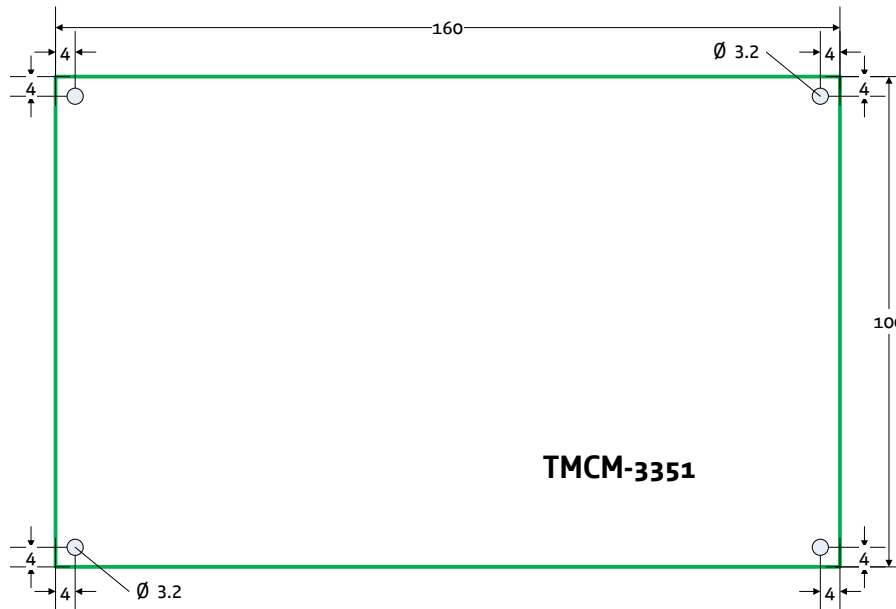

Figure 1: Board Dimensions and Positions of Mounting Holes (all Values in mm)



4 Connectors

The TMCM-3351 offers connectors for three stepper motors, related reference switches, related encoders (optional for closed-loop operation), a number of analog and digital inputs and outputs and several serial interfaces (RS485, CAN, USB and RS232).

NOTICE

Start with power supply OFF and do not connect or disconnect motor during operation! Motor cable and motor inductivity might lead to voltage spikes when the motor is (dis)connected while energized. These voltage spikes might exceed voltage limits of the driver MOSFETs and might permanently damage them. Therefore, always switch off / disconnect power supply or at least disable driver stage before connecting / disconnecting motor.

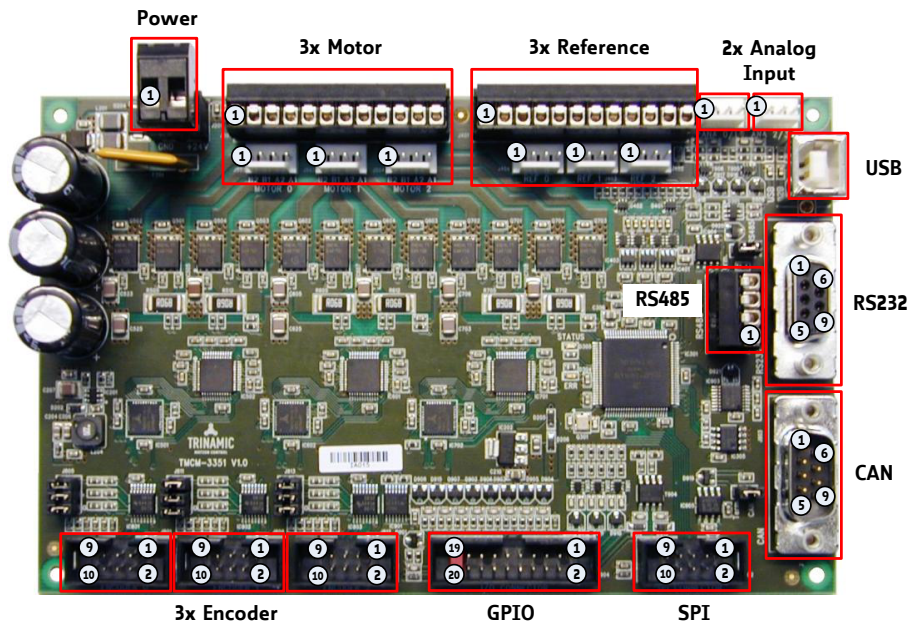

Figure 2: TMCM-3351 Connectors

Connector Types and Mating Connectors of the TMCM-3351		
Connector	Connector type on-board	Mating connector type
Power	RIA 320-02, 2 pins, 5mm pitch	RIA 349-02, screw type terminal block, pluggable , 2 pins, 5mm pitch
Motor	RIA 183-12, 12 pins, 3.5mm pitch	1x RIA 169-12 (12 pins) or e.g. 3x RIA 169-04 (4 pins, one connector for each motor), screw type terminal block, pluggable, 3.5mm pitch
	MOLEX type 6410, 2.54mm HH header, vertical friction lock	MOLEX type 2045, 2.54mm crimp housing, receptable, 4 pins



Connector	Connector type on-board	Mating connector type
Reference	RIA 183-12, 12 pins, 3.5mm pitch	1x RIA 169-12 (12 pins) or e.g. 3x RIA 169-04 (4 pins, one connector for each motor), screw type terminal block, pluggable, 3.5mm pitch
	MOLEX type 6410, 2.54mm HH header, vertical friction lock	MOLEX type 2045, 2.54mm crimp housing, receptable, 4 pins
Analog input	MOLEX type 6410, 2.54mm KK header, vertical friction lock	MOLEX type 2045, 2.54mm crimp housing, receptable, 4 pins
USB	USB, type B, 4 pins, vertical, female	USB, type B, 4 pins, male
RS232	DSUB, vertical, 9 pins, female	DSUB, vertical, 9 pins male
CAN	DSUB, vertical, 9 pins, male	DSUB, vertical, 9 pins female
RS485	RIA 183-4, 4 pins, 3.5mm pitch	RIA 169-4, 4 pins, screw type terminal block, pluggable, 3.5mm pitch
SPI	Amphenol type T821 low profile box header without locking bar, 2x5 pins, 2.54mm pitch	Amphenol type T812 low profile IDC socket connector, 2x5 pins, 2.54mm pitch
I/O	Amphenol type T821 low profile box header without locking bar, 2x10 pins, 2.54mm pitch	Amphenol type T812 low profile IDC socket connector, 2x10 pins, 2.54mm pitch
Encoder	Amphenol type T821 low profile box header without locking bar, 2x5 pins, 2.54mm pitch	Amphenol type T812 low profile IDC socket connector, 2x5 pins, 2.54mm pitch

Table 2: Connector Types and Mating Connectors of the TMCM-3351



4.1 Power Connector

A 2 pin, detachable screw connector is used for power supply input. All additional voltages required by the TMC3351 are generated on-board from this supply input.

Power Supply Connector Pin Assignment		
Pin	Label	Description
1	GND	Common system supply and signal ground
2	VDD	Power supply input, nom. +24V DC (+10V...+28.5VDC)

Table 3: Power Supply Connector Pin Assignment

4.2 Motor Connector

For the three motors 0...2 there are two connector options: either one detachable screw connector (can be used with either 12pin or 3x4pin mating connectors) intended for prototyping and smaller series or three crimp style connectors (Molex KK series) for higher volume / series.

NOTICE

Do not connect or disconnect motor during operation! Motor cable and motor inductivity might lead to voltage spikes when the motor is (dis)connected while energized. These voltage spikes might exceed voltage limits of the driver MOSFETs and might permanently damage them. Therefore, always switch off / disconnect power supply or at least disable driver stage before connecting / disconnecting motor.

Motor Connector (Detachable Screw Connector)		
Pin	Label	Description
1	Motor_0_B-	Motor 0, coil B
2	Motor_0_B+	Motor 0, coil B
3	Motor_0_A-	Motor 0, coil A
4	Motor_0_A+	Motor 0, coil A
5	Motor_1_B-	Motor 1, coil B
6	Motor_1_B+	Motor 1, coil B
7	Motor_1_A-	Motor 1, coil A
8	Motor_1_A+	Motor 1, coil A
9	Motor_2_B-	Motor 2, coil B
10	Motor_2_B+	Motor 2, coil B
11	Motor_2_A-	Motor 2, coil A
12	Motor_2_A+	Motor 2, coil A

Table 4: Motor Connector (Detachable Screw Connector)



Motor Connector (Crimp Style Connector)		
Pin	Label	Description
1	Motor_0/1/2_B-	Motor 0/1/2 coil B
2	Motor_0/1/2_B+	Motor 0/1/2 coil B
3	Motor_0/1/2_A-	Motor 0/1/2 coil A
4	Motor_0/1/2_A+	Motor 0/1/2 coil A

Table 5: Motor Connector (Crimp Style Connector)

4.3 End Switch Connector

For the stop switch inputs (two stop switches per motor axis are supported) there are two connector options: either one detachable screw connector (can be used with either 12pin or 3x4pin mating connectors) intended for prototyping and smaller series or three crimp style connectors (Molex KK series) for higher volume / series.

End Switch Connector (Detachable Screw Connector)		
Pin	Label	Description
1	STOP_0_R	Motor 0, right stop switch input
2	STOP_0_L	Motor 0, left stop switch input
3	GND	System / module ground
4	+5V	+5V supply output for active switches
5	STOP_1_R	Motor 1, right stop switch input
6	STOP_1_L	Motor 1, left stop switch input
7	GND	System / module ground
8	+5V	+5V supply output for active switches
9	STOP_2_R	Motor 2, right stop switch input
10	STOP_2_L	Motor 2, left stop switch input
11	GND	System / module ground
12	+5V	+5V supply output for active switches

Table 6: End Switch Connector (Detachable Screw Connector)

End Switch Connector (Crimp Style Connector)		
Pin	Label	Description
1	STOP_0/1/2_R	Motor 0/1/2, right stop switch input
2	STOP_0/1/2_L	Motor 0/1/2, left stop switch input
3	GND	System / module ground
4	+5V	+5V supply output for active switches



Pin	Label	Description
-----	-------	-------------

Table 7: End Switch Connector (Crimp Style Connector)

4.4 Analog Input Connector

The TMCM-3351 offers four dedicated analog inputs with programmable range (0...+3.3V or 0...+10V). There are two 4-pin connectors (Molex KK series) with two analog inputs available via each connector.

Analog Input Connector		
Pin	Label	Description
1	Analog_0/2	Analog input 0/2
2	GND	System / module ground
3	Analog_1/3	Analog input 1/3
4	GND	System / module ground

Table 8: Analog Input Connector

4.5 USB Connector

The TMCM-3351 includes one USB device interface for serial communication. A standard USB type B connector is integrated on-board. USB is one out of four different interfaces available for communication with the TMCM-3351.

The TMCM-3351 supports USB bus powered and self powered operation. During bus powered operation the on-board digital core logic including processor and non-volatile memory (EEPROM) will be supplied via USB. That is, just the USB connection is required for communication and power supply. This mode is intended for firmware updates, TMCL program download or parameter setting / read-out of the non-volatile (EEPROM) memory. Of course, motor operation is not possible in this mode due to limited voltage and power available via USB.

For USB self-powered operation an external power supply is required with power supply inputs via the main power supply connector. Please note that the TMCM-3351 might draw power from the USB connection depending on voltage levels.

USB Connector		
Pin	Label	Description
1	VBUS	+5V
2	USB_D-	Data-
3	USB_D+	Data+
4	GND	System / module ground

Table 9: USB Connector



4.6 RS232 Connector

The board includes one RS232 interface for serial connection. A standard DSUB 9pin female connector is integrated on-board for RS232 connection. RS232 is one out of four different interfaces available for communication with the TMCM-3351.

RS232 Connector		
Pin	Label	Description
2	RS232_TxD	RS232 transmit serial data
3	RS232_RxD	RS232 receive serial data
5	GND	System / module ground
1, 4, 6, 7, 8, 9	n.c.	Pins not connected

Table 10: RS232 Connector

For communication via RS232 transmit serial data of the TMCM-3351 has to be connected to RS232 receive serial data of the host / master and RS232 receive data of the TMCM-3351 to transmit data of the host / master - requiring a cross-connection / -cable.

In contrast to the TMCM-351 the TMCM-3351 does not require any jumper setting / selection in order to enable RS232 connection. RS232 communication is available after power-up (power supply input) without any further configuration.

4.7 CAN Connector

The board includes one CAN bus interface for serial connection. A standard DSUB 9pin male connector is integrated on-board for CAN bus connection. CAN is one out of four different interfaces available for communication with the TMCM-3351.

With CANopen firmware communication using the CANopen protocol is available via this connector.

CAN Connector		
Pin	Label	Description
2	CAN_L	CAN differential bus
7	CAN_H	CAN differnetial bus
3, 6	GND	System / module ground
1, 4, 5, 8, 9	n.c.	Pins not connected

Table 11: CAN Connector

The TMCM-3351 offers on-board line-termination for the CAN bus (120R). For proper operation the CAN bus should be terminated at both ends of the bus. For any intermediate nodes / bus connections please remove line termination jumper (see 5, also).

4.8 RS485 Connector

The board includes one RS485 bus interface for serial connection. A 4pin detachable screw connector is integrated on-board for RS485 bus connection. RS485 is one out of four different interfaces available for communication with the TMCM-3351.



RS485 Connector		
Pin	Label	Description
1	RS485+	RS485 differential bus (connected to pin 3)
2	RS485-	RS485 differential bus (connected to pin 4)
3	RS485+	RS485 differential bus (connected to pin 1)
4	RS485-	RS485 differential bus (connected to pin 2)

Table 12: RS485 Connector

The TMCM-3351 offers on-board line-termination for the RS485 bus (120R). For proper operation the RS485 bus should be terminated at both ends of the bus. For any intermediate nodes / bus connections please remove line termination jumper (see 5, also).

In contrast to the TMCM-351 the TMCM-3351 does not require any jumper setting / selection in order to enable RS485 connection. RS485 communication is available after power-up (power supply input) without any further configuration.

4.9 SPI Connector

For extension of the available inputs and outputs an SPI interface is available. A 2.54mm pitch two row Amphenol type T821 low profile box header is used.

SPI Connector			
Pin	Label	Pin	Label
1	SPI_MOSI	2	GND
3	SPI_MISO	4	GND
5	SPI_CLK	6	GND
7	SPI_SEL0	8	SPI_SEL2
9	SPI_SEL1	10	+5V_output

Table 13: SPI Connector

4.10 I/O Connector

The general purpose I/O connector offers 8 digital and analog inputs and 8 digital outputs. All inputs are +24V compatible. All outputs offer open collector driver stages. OUT_0...5 can sink up-to 100mA while OUT_6...7 are more powerful and can sink up to 2A. A 2.54mm pitch two row Amphenol type T821 low profile box header is used.

I/O Connector			
Pin	Label	Pin	Label
1	OUT_0	2	OUT_1
3	OUT_2	4	OUT_3
5	OUT_4	6	OUT_5



Pin	Label	Pin	Label
7	OUT_6	8	OUT_7
9	+5V_output	10	GND
11	IN_0	12	IN_1
13	IN_2	14	IN_3
15	IN_4	16	IN_5
17	IN_6	18	IN_7
19	/Shutdown	20	VDD

Table 14: I/O Connector

The /Shutdown input pin has to be connected to the supply voltage in order to enable the driver stages for all three stepper motor axes. A jumper between pin 19 and pin 20 can be used to permanently enable drivers (please refer to section 5 for more detailed information).

4.11 Encoder Connector

Three encoder connectors (one dedicated encoder interface and connector per axis) are available. A 2.54mm pitch two row Amphenol type T821 low profile box header is used. Incremental a/b/n encoder with differential or single ended (push-pull TTL or open-drain) output signals are supported.

For encoder with single ended output signals the non-inverting inputs of the encoder connector should be used (A+, B+ and N+). Please do not activate encoder line termination for single ended encoder signals (remove jumpers). Refer to section 5 for more details.

For encoder with differential output signals the non-inverting and inverting signal pairs should be connected (A+ and A-, B+ and B-, N+ and N-) and on-board line termination might be activated (setting jumpers - refer to section 5 for more details).

Incremental encoders with +24V push-pull output signals are not supported. Please use appropriate interface circuits for these types of encoders.

Encoder Connector			
Pin	Label	Pin	Label
1	GND	2	GND
3	Encoder_0/1/2_N+	4	Encoder_0/1/2_N-
5	Encoder_0/1/2_A+	6	Encoder_0/1/2_A-
7	+5V_output	8	+5V_output
9	Encoder_0/1/2_B+	10	Encoder_0/1/2_B-

Table 15: Encoder Connector



5 Jumper Settings

Most settings for the TMCM-3351 are done through software. Nevertheless, a few jumpers are available for configuration.

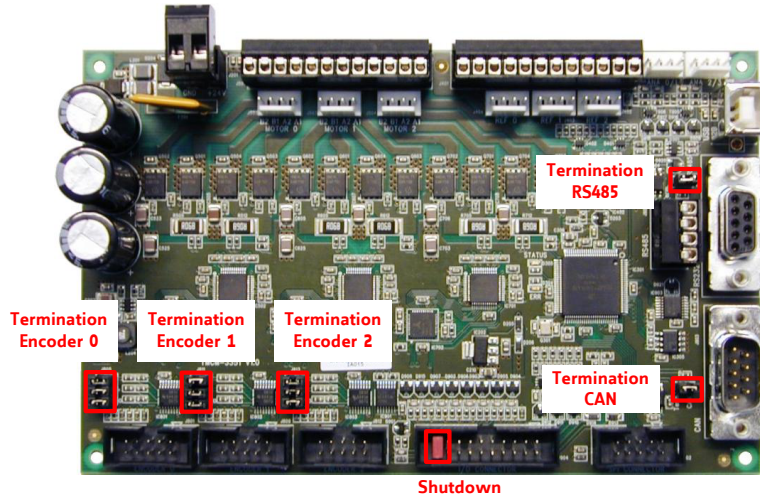

Figure 3: Jumper Settings

Jumper Settings	
Jumper	Description
Termination RS485	Jumper added - termination (120R resistor between RS485+ and RS485-) is enabled. For proper operation the RS485 bus should be terminated at both ends. Termination should be disabled (jumper removed) for any nodes in-between.
Termination CAN	Jumper added - termination (120R resistor between CAN_H and CAN_L) is enabled. For proper operation the CAN bus should be terminated at both ends. Termination should be disabled (jumper removed) for any nodes in-between.
Termination Encoder 0	Termination for encoder line receiver input 0. Encoder input 0 is related to motor axis 0. For differential encoder signals – especially with longer cables and / or noisy environment it is recommended to add jumpers for activation of line termination (120R resistor between each differential pair – A+ and A-, B+ and B-, N+ and N-).
Termination Encoder 1	Termination for encoder line receiver input 1. Encoder input 1 is related to motor axis 1. For differential encoder signals – especially with longer cables and / or noisy environment it is recommended to add jumpers for activation of line termination (120R resistor between each differential pair – A+ and A-, B+ and B-, N+ and N-).



Jumper	Description
Termination Encoder 2	Termination for encoder line receiver input 2. Encoder input 2 is related to motor axis 0. For differential encoder signals – especially with longer cables and / or noisy environment it is recommended to add jumpers for acitvation of line termination (120R resistor between each differential pair – A+ and A-, B+ and B-, N+ and N-)

Table 16: Jumper Settings

5.1 Encoder input termination

For enhanced reliability differential encoder signals should be terminated properly. The board offers termination resistors (120 Ohm) for all three encoder interface signals (a/b/n) for all three encoders. By setting jumpers, these resistors will be placed between the differential encoder signals. Do not set these jumpers in case encoders with single ended signals are used.

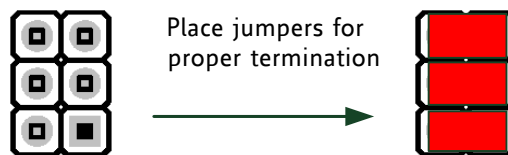

Figure 4: Encoder input termination

5.2 Enable all driver stages permanently

The /Shutdown input pin has to be connected to the supply voltage in order to enable the driver stages for all three stepper motor axes. A jumper between pin 19 and pin 20 can be used to permanently enable drivers.

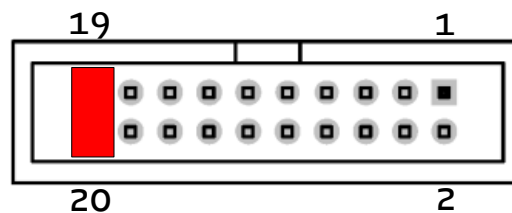

Figure 5: Enable all driver stages permanently



6 LEDs

Both on-board LEDs (one green and one red) are connected directly to the on-board microcontroller. Therefore, function of the LEDs is depending on firmware.

LED Description		
Status	Label	Description
LED Status (green)	STATUS	<i>with TMCL firmware:</i> LED flashing: normal operation LED permanently on: bootloader mode incl. firmware update LED flashing fast: reset to factory default settings
LED Error (red)	ERR	<i>with TMCL firmware:</i> LED off: normal operation LED permanently on: error

Table 17: LED Description

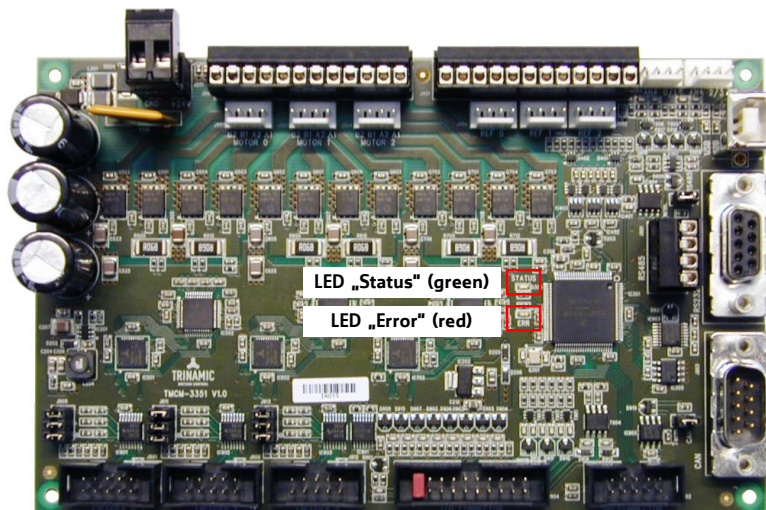

Figure 6: TMCM-3351 LEDs



7 Communication

7.1 RS485

For remote control and communication with a host system the TMCM-3351 provides a two wire RS485 bus interface. For proper operation the following items should be taken into account when setting up an RS485 network:

1. **BUS STRUCTURE:**

The network topology should follow a bus structure as closely as possible. That is, the connection between each node and the bus itself should be as short as possible. Basically, it should be short compared to the length of the bus.

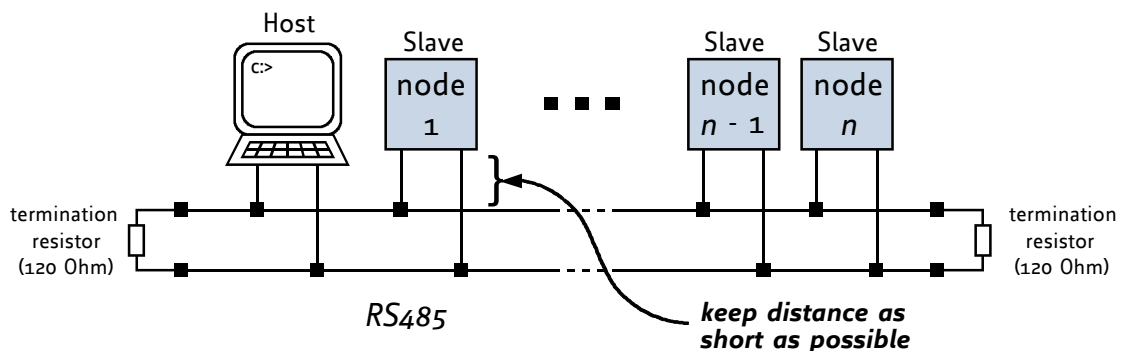

Figure 7: RS485 bus structure with termination resistors

2. **BUS TERMINATION:**

Especially for longer busses and/or multiple nodes connected to the bus and/or high communication speeds, the bus should be properly terminated at both ends. Termination resistor (120 Ohm) maybe added externally at both ends of the bus or the on-board termination maybe activated by adding a jumper (see 5).

3. **NUMBER OF NODES:**

The RS485 electrical interface standard (EIA-485) allows up to 32 nodes to be connected to a single bus. The bus transceiver used on the TMCM-3351 units (SN65HVD3082ED) has just 1/8th of the standard bus load and allows a maximum of 256 units to be connected to a single RS485 bus.

4. **NO FLOATING BUS LINES:**

Avoid floating bus lines while neither the host/master nor one of the slaves along the bus line is transmitting data (all bus nodes switched to receive mode). Floating bus lines may lead to communication errors. In order to ensure valid signals on the bus it is recommended to use a resistor network connecting both bus lines to GND resp. +5V. In contrast to the termination resistors this network is normally required just once per bus. Certain RS485 interface converters available for PCs already include these additional resistors (e.g. USB-2-485).



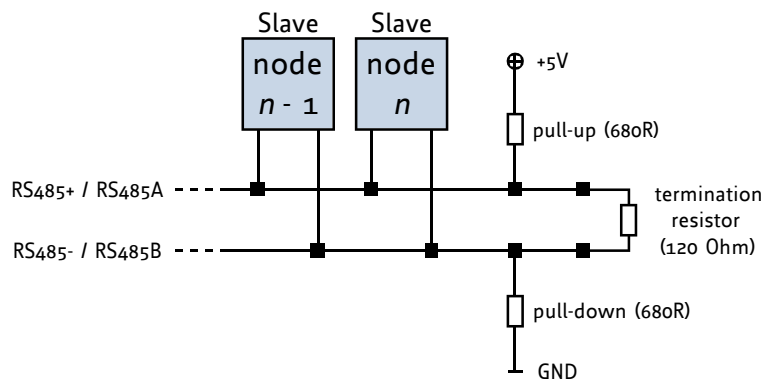

Figure 8: RS485 bus lines with resistor network

7.2 USB

For remote control and communication with a host system the TMCM-3351 provides a USB 2.0 full-speed (12Mbit/s) interface (USB Type B connector). As soon as a USB-Host is connected the module will accept commands via USB. The TMCM-3351 supports USB self powered operation (External power supplied via the power supply connector) and USB bus powered operation, also (no external power is supplied via the power supply connector). During USB bus powered operation, only the core digital circuit parts will be operational. That is, the microcontroller itself and also the EEPROM. Of course, any motor movement will not be possible in this mode. This mode has been implemented in order to enable configuration / parameter setting / read-out, firmware updates etc. by just connecting a USB cable between the module and a host PC. No other connection / additional power supply is required.

7.3 CAN

For remote control and communication with a host system the TMCM-3351 provides a CAN bus interface. For proper operation the following items should be taken into account when setting up a CAN network:

1. BUS STRUCTURE:

The network topology should follow a bus structure as closely as possible. That is, the connection between each node and the bus itself should be as short as possible. Basically, it should be short compared to the length of the bus.

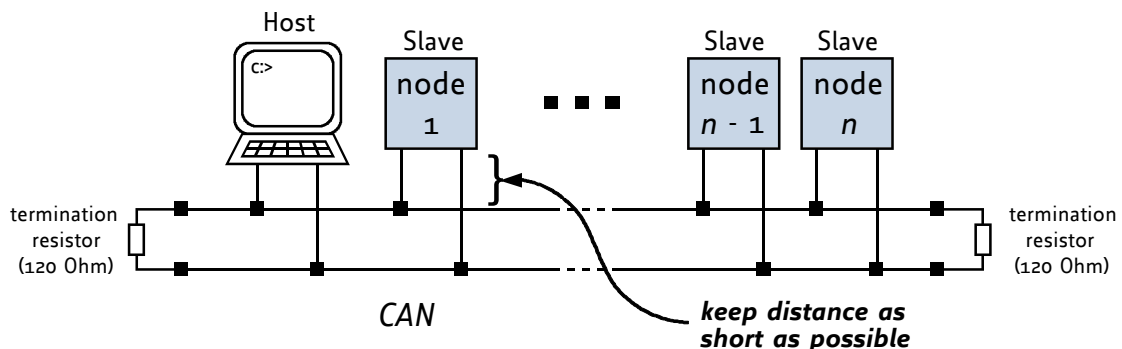

Figure 9: CAN bus structure with termination resistors

2. BUS TERMINATION:

Especially for longer busses and/or multiple nodes connected to the bus and/or high communication



speeds, the bus should be properly terminated at both ends. The TMCM-3351 does not integrate any termination resistor. Termination resistor (120 Ohm) maybe added externally at both ends of the bus or the on-board termination maybe activated by adding a jumper (see [5](#)).



8 Motor Driver Current

The on-board stepper motor driver operates current controlled. The driver current may be programmed in software with 32 effective current scaling steps (CS) in hardware.

Explanation of different columns in table below:

- Motor current setting in software (TMCL)** These are the values for TMCL axis parameter 6 (motor run current) and 7 (motor standby current). They are used to set the run / standby current using the following TMCL commands:
 SAP 6, 0, <value> // set run current
 SAP 7, 0, <value> // set standby current
 (read-out value with GAP instead of SAP. Please see separate TMCM-3351 firmware manual for further information)
- Current scaling** This is the effective current scaling in hardware. 32 different scaling steps are available in hardware.
- Motor current** Resulting motor current based on motor current setting. Motor current is listed as peak (sine peak) value (I_{PEAK}) and RMS-value (I_{RMS}). For stepper motors rated current is usually listed as I_{RMS} value.

Motor Current Settings			
Motor current setting in software (TMCL)	Current scaling step in hardware (CS)	Motor current $I_{PEAK}[A]$	Motor current $I_{RMS}[A]$
0..7	0	0.149	0.106
8..15	1	0.299	0,211
16..23	2	0.448	0.317
24..31	3	0.597	0.422
32..39	4	0.747	0.528
40..47	5	0.896	0.634
48..55	6	1.045	0.739
56..63	7	1.195	0.845
64..71	8	1.344	0.950
72..79	9	1.494	1.056
80..87	10	1.643	1.162
88..95	11	1.792	1.267
96..103	12	1.942	1.373
104..111	13	2.091	1.479
112..119	14	2.240	1.584
120..127	15	2.390	1.690
128..135	16	2.539	1.795



Motor current setting in software (TMCL)	Current scaling step in hardware (CS)	Motor current $I_{PEAK}[A]$	Motor current $I_{RMS}[A]$
136..143	17	2.688	1.901
144..151	18	2.838	2.007
152..159	19	2.987	2.112
160..167	20	3.136	2,218
168..175	21	3.286	2.323
176..183	22	3.435	2.429
184..191	23	3.585	2.535
192..199	24	3.734	2.640
200..207	25	3.883	2.746
208..215	26	4.033	2.851
216..223	27	4.182	2.957
224..231	28	4.331	3.063
232..239	29	4.481	3.168
240..247	30	4.630	3.274
248..255	31	4.779	3.380

Table 18: Motor Current Settings

In addition to the settings in the table the motor current may be switched off completely (free-wheeling) using axis parameter 204 (see TMC3351 TMCL Firmware Manual).



9 Functional Description

The TMCM-3351 is a highly integrated 3-axes controller/driver module for stepper motors. It offers separate motion controllers in hardware for all three axes supporting linear and S-shaped ramps, open-loop operation and closed-loop operation with external encoder. The TMCM-3351 can be controlled via one out of four available serial interfaces RS485, CAN, RS232 or USB. In addition, the module offers a larger number of digital inputs and outputs and analog inputs. All digital inputs accept +24V compatible signals and all outputs offer open-collector driver (low-side switches).

The TMCM-3351 comes with the PC based software development environment TMCL-IDE for the Trinamic Motion Control Language (TMCL™). Using predefined TMCL™ high level commands like *move to position* a rapid and fast development of motion control applications is guaranteed. Whereas the boot loader is installed during production and testing at TRINAMIC and remains usually untouched throughout the whole lifetime, the firmware can be updated by the user.

Communication traffic is kept low since all time critical operations, e.g. ramp calculation, are performed on-board. Full remote control of the device with feedback is possible. The firmware of the module can be updated via any of the serial interfaces.

The TMCM-3351 module contains the following main components:

- Microcontroller, responsible for overall control and communication
- Motion controller in hardware for ramp calculation in real-time, featuring linear and S-shaped ramps, open-loop operation and closed loop operation with external encoder.
- external encoder interface - one for each axis - supporting incremental a/b/n encoder with either single ended +5V push-pull (TTL), open-collector or differential signals
- 8 general purpose inputs, 8 general purpose outputs and 4 dedicated analog inputs
- 1 shutdown input for all three axes (enable / disable driver stage in hardware)
- RS485, CAN, RS232 and USB serial communication interfaces

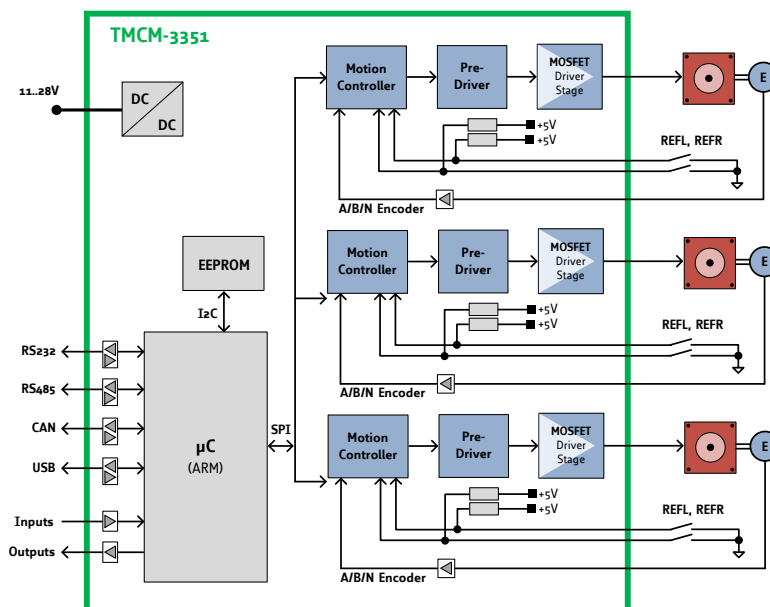

Figure 10: TMCM-3351 Block Diagram



10 Operational Ratings and Characteristics

NOTICE

Never exceed the absolute maximum ratings! Keep the power supply voltage below the upper limit of +30V! Otherwise the board electronics will seriously be damaged! Especially, when the selected operating voltage is near the upper limit a regulated power supply is highly recommended.

General operational Ratings of the Module					
Symbol	Parameter	Min	Typ	Max	Unit
V_{Power}	Power supply voltage	11	12...24	28	V
V_{USB}	Power supply via USB connector		5		V
I_{USB}	Current withdrawn from USB supply when USB bus powered (no other supply connected)		135		mA
I_{COIL}	Motor coil current for sine wave peak (chopper regulated, adjustable via software)	0		4500	mA
I_{MC}	Continuous motor current (RMS)	0		3300	mA
T_{ENV}	Environmental temperature at rated current (no forced cooling required)	-30		tbd	°C

Table 19: General operational Ratings of the Module

Operational Ratings of the general purpose I/Os					
Symbol	Parameter	Min	Typ	Max	Unit
$V_{OUT_0...7}$	Voltage at open drain outputs OUT_0...7	0		V_{Power}	V
$I_{OUT_0...5}$	Output sink current of open-collector outputs OUT_0...5			100	mA
$I_{OUT_6...7}$	Output sink current of open-drain outputs OUT_6...7			2000	mA
$V_{IN_0...7}$	Input voltage for IN_0...7			28	V
$V_{IN_L_0...7}$	Low level input voltage for IN_0...7	0		0.4	V
$V_{IN_H_0...7}$	High level input voltage for IN_0...7	4		28	V

Table 20: Operational Ratings of the general purpose I/Os

Operational Ratings of the CAN Interface					
Symbol	Parameter	Min	Typ	Max	Unit
N_{CAN}	Number of nodes connected to single CAN network			>110	
f_{CAN}	Maximum bit rate supported on CAN network		1000000	1000000	bit/s

Table 21: Operational Ratings of the CAN Interface



Operational Ratings of the RS485 Interface					
Symbol	Parameter	Min	Typ	Max	Unit
N_{RS485}	Number of nodes connected to single RS485 network			256	
f_{RS485}	Maximum bit rate supported on RS485 network		9600	1000000	bit/s

Table 22: Operational Ratings of the RS485 Interface

Operational Ratings of the RS232 Interface					
Symbol	Parameter	Min	Typ	Max	Unit
f_{RS232}	Maximum bit rate supported on RS232 interface			1000000	bit/s

Table 23: Operational Ratings of the RS232 Interface



11 Abbreviations used in this Manual

Abbreviation	Description
IDE	Integrated Development Environment
LED	Light Emmitting Diode
RMS	Root Mean Square value
TMCL	TRINAMIC Motion Control Language

Table 24: Abbreviations used in this Manual



12 Figures Index

1	Board Dimensions and Positions of Mounting Holes (all Values in mm) . . .	6	7	RS485 bus structure with termination resistors	18
2	TMCM-3351 Connectors	7	8	RS485 bus lines with resistor network	19
3	Jumper Settings	15	9	CAN bus structure with termination resistors	19
4	Encoder input termination	16	10	TMCM-3351 Block Diagram	23
5	Enable all driver stages permanently	16			
6	TMCM-3351 LEDs	17			



13 Tables Index

1	TMCM-3351 Order Codes	5	14	I/O Connector	14
2	Connector Types and Mating Connectors of the TMCM-3351	8	15	Encoder Connector	14
3	Power Supply Connector Pin Assignment	9	16	Jumper Settings	16
4	Motor Connector (Detachable Screw Connector)	9	17	LED Description	17
5	Motor Connector (Crimp Style Connector)	10	18	Motor Current Settings	22
6	End Switch Connector (Detachable Screw Connector)	10	19	General operational Ratings of the Module	24
7	End Switch Connector (Crimp Style Connector)	11	20	Operational Ratings of the general purpose I/Os	24
8	Analog Input Connector	11	21	Operational Ratings of the CAN Interface	24
9	USB Connector	11	22	Operational Ratings of the RS485 Interface	25
10	RS232 Connector	12	23	Operational Ratings of the RS232 Interface	25
11	CAN Connector	12	24	Abbreviations used in this Manual	26
12	RS485 Connector	13	25	Hardware Revision	31
13	SPI Connector	13	26	Document Revision	31



14 Supplemental Directives

14.1 Producer Information

14.2 Copyright

TRINAMIC owns the content of this user manual in its entirety, including but not limited to pictures, logos, trademarks, and resources. © Copyright 2021 TRINAMIC. All rights reserved. Electronically published by TRINAMIC, Germany.

Redistribution of sources or derived formats (for example, Portable Document Format or Hypertext Markup Language) must retain the above copyright notice, and the complete data sheet, user manual, and documentation of this product including associated application notes; and a reference to other available product-related documentation.

14.3 Trademark Designations and Symbols

Trademark designations and symbols used in this documentation indicate that a product or feature is owned and registered as trademark and/or patent either by TRINAMIC or by other manufacturers, whose products are used or referred to in combination with TRINAMIC's products and TRINAMIC's product documentation.

This Hardware Manual is a non-commercial publication that seeks to provide concise scientific and technical user information to the target user. Thus, trademark designations and symbols are only entered in the Short Spec of this document that introduces the product at a quick glance. The trademark designation /symbol is also entered when the product or feature name occurs for the first time in the document. All trademarks and brand names used are property of their respective owners.

14.4 Target User

The documentation provided here, is for programmers and engineers only, who are equipped with the necessary skills and have been trained to work with this type of product.

The Target User knows how to responsibly make use of this product without causing harm to himself or others, and without causing damage to systems or devices, in which the user incorporates the product.

14.5 Disclaimer: Life Support Systems

TRINAMIC Motion Control GmbH & Co. KG does not authorize or warrant any of its products for use in life support systems, without the specific written consent of TRINAMIC Motion Control GmbH & Co. KG.

Life support systems are equipment intended to support or sustain life, and whose failure to perform, when properly used in accordance with instructions provided, can be reasonably expected to result in personal injury or death.

Information given in this document is believed to be accurate and reliable. However, no responsibility is assumed for the consequences of its use nor for any infringement of patents or other rights of third parties which may result from its use. Specifications are subject to change without notice.

14.6 Disclaimer: Intended Use

The data specified in this user manual is intended solely for the purpose of product description. No representations or warranties, either express or implied, of merchantability, fitness for a particular purpose



or of any other nature are made hereunder with respect to information/specification or the products to which information refers and no guarantee with respect to compliance to the intended use is given.

In particular, this also applies to the stated possible applications or areas of applications of the product. TRINAMIC products are not designed for and must not be used in connection with any applications where the failure of such products would reasonably be expected to result in significant personal injury or death (safety-Critical Applications) without TRINAMIC's specific written consent.

TRINAMIC products are not designed nor intended for use in military or aerospace applications or environments or in automotive applications unless specifically designated for such use by TRINAMIC. TRINAMIC conveys no patent, copyright, mask work right or other trade mark right to this product. TRINAMIC assumes no liability for any patent and/or other trade mark rights of a third party resulting from processing or handling of the product and/or any other use of the product.

14.7 Collateral Documents & Tools

This product documentation is related and/or associated with additional tool kits, firmware and other items, as provided on the product page at: www.trinamic.com.



15 Revision History

15.1 Hardware Revision

Version	Date	Author	Description
V1.0	2017-MAY-04	GE	First prototypes

Table 25: Hardware Revision

15.2 Document Revision

Version	Date	Author	Description
0.90	2017-JUN-20	GE	First version, based on TMC351 hardware manual V1.07. / 2012-DEC-17
0.91	2017-JUL-11	GE	Chapter with motor current settings added, jumper settings explained in more detail.
1.00	2017-SEP-01	OK	Harmonized with firmware manuals.
1.01	2021-SEP-08	MM	Clarified connector type for SPI, I/O and Encoder interfaces. Order codes corrected.

Table 26: Document Revision

