

TMCM-1633 Hardware Manual

Hardware Version V1.00 | Document Revision V1.01 • 2021-Feb-03

The TMCM-1633 is a single axis controller module for brushless DC (BLDC) and PMSM motors. It offers field oriented control (FOC) with up-to 10A RMS phase currents at +48V DC supply. Besides hall sensor and incremental ABN encoder interfaces for connection to the motor, digital inputs and outputs can be used. A CAN interface allows communication with a CANopen master.

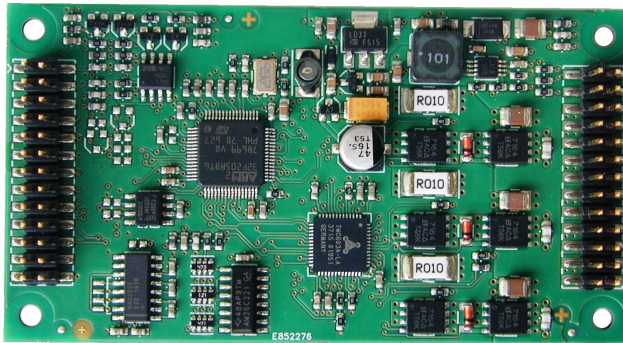

Features

- Single axis field oriented control for BLDC/PMSM motor
- Hall and ABN encoder support
- +14,5..48V DC supply voltage
- Up to 10A RMS peak motor current
- RS232 & CAN interface
- CANopen CiA 402 drive profile
- Torque, Velocity, and Position control

Applications

- Life Sciences
- Test & Measurement
- Robotics / Automation

Simplified Block Diagram

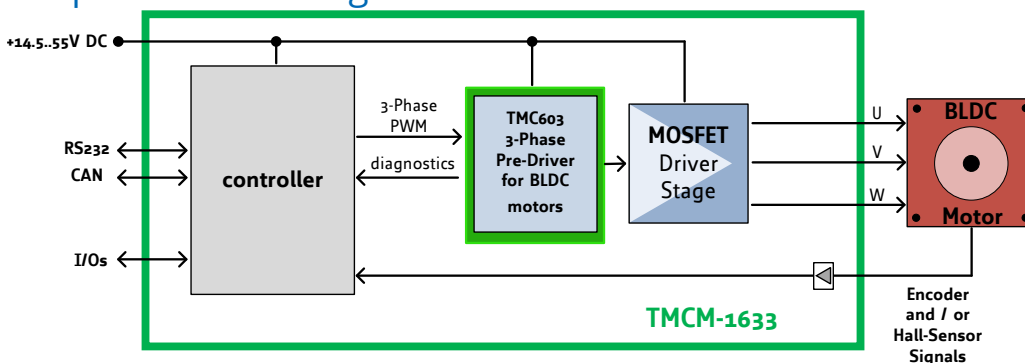

Contents

1 Features	3
1.1 General Features	3
2 Order Codes	4
3 Mechanical and Electrical Interfacing	5
3.1 TMC-1633 Dimensions and Weight	5
3.2 Mounting Considerations	5
4 Connectors	6
4.1 Power Supply and Motor Connector	8
4.1.1 Power supply requirements	9
4.2 I/O, Interface and Encoder Connector	9
4.2.1 Reset the module to factory defaults	10
4.2.2 Inputs	10
4.2.3 Encoder inputs	11
4.2.4 Outputs	12
5 Status LEDs	14
6 Functional Description	15
7 Operational Ratings and Characteristics	16
7.1 Absolute Maximum Ratings	16
8 Abbreviations used in this Manual	17
9 Figures Index	18
10 Tables Index	19
11 Supplemental Directives	20
11.1 Producer Information	20
11.2 Copyright	20
11.3 Trademark Designations and Symbols	20
11.4 Target User	20
11.5 Disclaimer: Life Support Systems	20
11.6 Disclaimer: Intended Use	20
11.7 Collateral Documents & Tools	21
12 Revision History	22
12.1 Hardware Revision	22
12.2 Document Revision	22



1 Features

TMCM-1633 is a highly integrated single axis controller/driver module for brushless DC motors (BLDC) with RS232 and CAN interface and support for CANopen. The unit (size: 50mm x 92.5mm) has been designed in order to be plugged onto a baseboard. It offers hall sensor (TTL or open-drain) and encoder (incremental a/b/n) inputs and additional inputs and outputs.

1.1 General Features

Main Characteristics

- Supply Voltage +24V or +48V DC nominal (+14.5 ... +50V DC max.)
- BLDC motors with hall sensors and / or encoder are supported
- 10A RMS phase current (programmable) peak
- CANopen firmware

Interfaces

- CAN
- RS232

Inputs

- 2 analog inputs and 2 digital inputs
- Encoder interface (incremental ABN with differential, 5V TTL or open-drain signalling)
- Hall sensor interface (5V TTL or open-drain)

Outputs

- 3 open-drain outputs

Software

- CANopen™



2 Order Codes

Order Code	Description	Size (LxWxH)
TMCM-1633-2C-CANopen	1-axis BLDC plug-in controller/driver module, FOC, 10A RMS peak, +48VDC, RS232 + CAN, with CANopen firmware	92.5mm x 50mm x 14mm

Table 1: Order code module



3 Mechanical and Electrical Interfacing

3.1 TCCM-1633 Dimensions and Weight

The module TCCM-1633 has a size of approximately 92.5mm x 50mm and an overall height of approx. 14mm including connectors. It offers four mounting holes (diameter: 3.2mm).

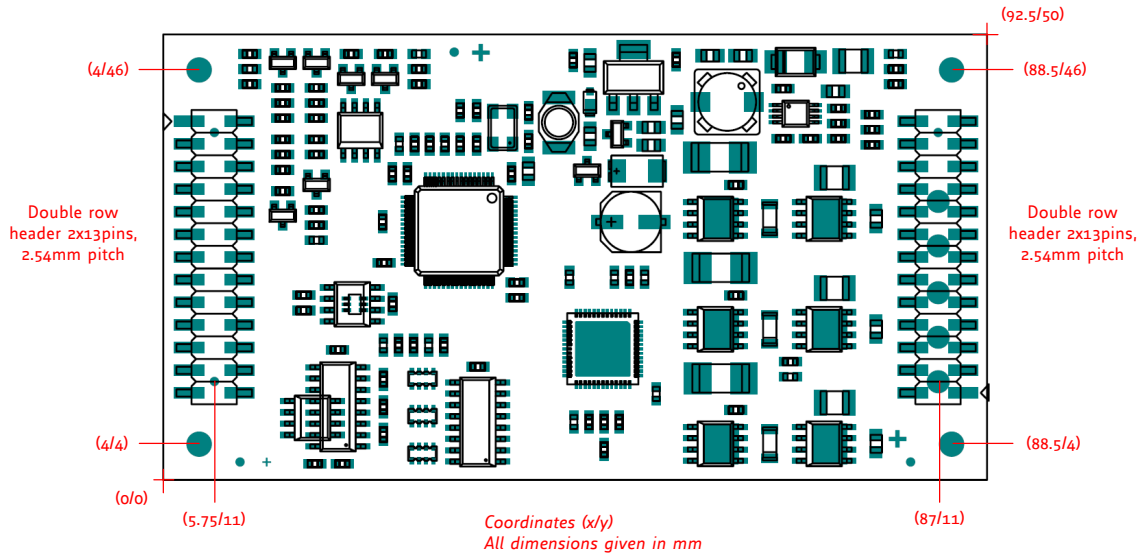

Figure 1: TCCM-1633 mechanical dimensions

Order Code	Description	Dimensions in mm	Weight in g
TCCM-1633-2C-CANopen	1-axis BLDC plug-in controller/-driver module, FOC, 10A RMS peak, +48VDC, RS232 + CAN, with CANopen firmware	92.5mm x 50mm x 14mm	≈ 29

Table 2: TCCM-1633size and weight

3.2 Mounting Considerations

TCCM-1633 has been designed as a plug-in module. It usually requires a baseboard for operation. Connection to the baseboard is made via two connectors at both ends of the bottom of the pcb. There are four mounting holes for securing the board / keeping it in position in addition to the connectors. Usually at least one screw hole at each end of the board should be used to avoid any disconnection of the board from a baseboard during transportation or operation (vibrations inside a machine etc.).



4 Connectors

The module offers two double row 2.54mm pitch standard connectors, one at each end of the board.

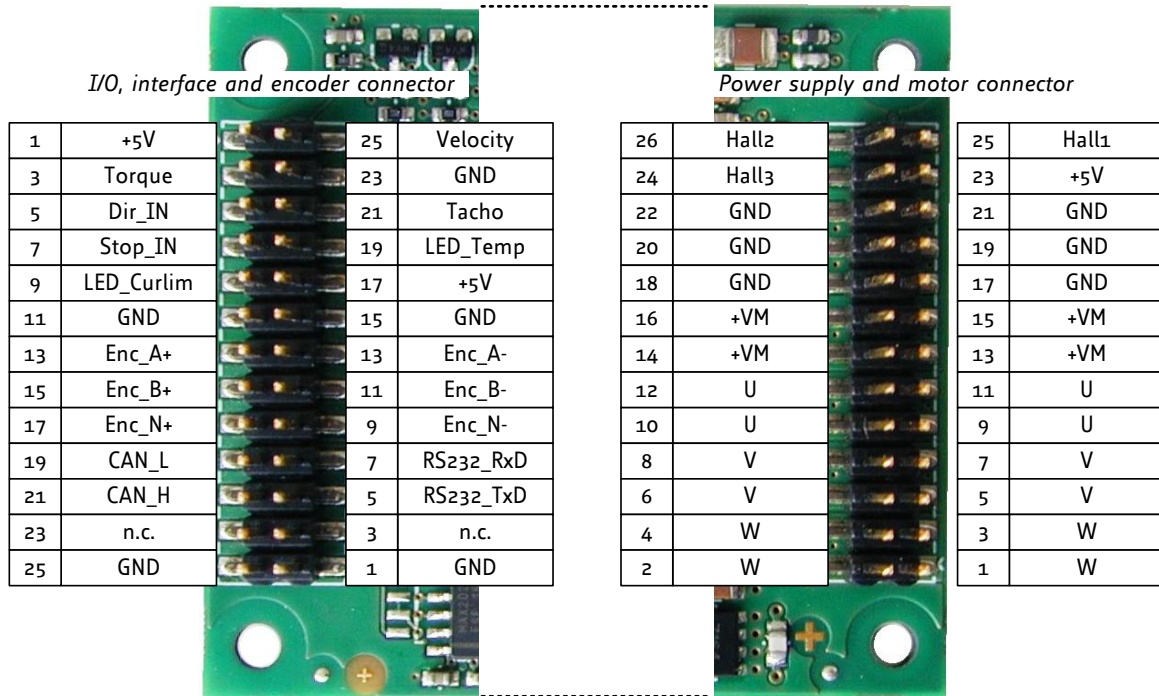

Figure 2: TMCM-1633 Connector

Connector	Connector type on-board	Mating connector type
I/O, interface and encoder	TSM-113-03-L-DV-K-A, 2x13 pins, double row, 2.54mm pitch, SMT vertical, Samtec or similar type	Samtec: SSW, SSQ, SSM, BSW, ESW, ESQ, BCS, SLW, CES, HLE, IDSS or IDSD series or any double row 2.54mm pitch 2x13pin female connector
Power supply and motor	TSM-113-03-L-DV-K-A, 2x13 pins, double row, 2.54mm pitch, SMT vertical, Samtec or similar type	Samtec: SSW, SSQ, SSM, BSW, ESW, ESQ, BCS, SLW, CES, HLE, IDSS or IDSD series or any double row 2.54mm pitch 2x13pin female connector

Table 3: Connector type and mating connector of the TMCM-1633

NOTICE

Do not plug-in or remove unit from baseboard during operation! This may result in permanent damage of the unit.

NOTICE

Pay attention to orientation of unit and alignment of pins when inserting unit! Please be careful not to insert the unit the other way round. Also, please make sure all pins are inserted into their mating pins.



Especially for higher motor current an assembly option with a detachable screw connector is available on request (minimum order quantity required). The 5pin connector will be assembled on top side of board and includes power supply input (+VM and GND) and motor coil connections (U, V, W):

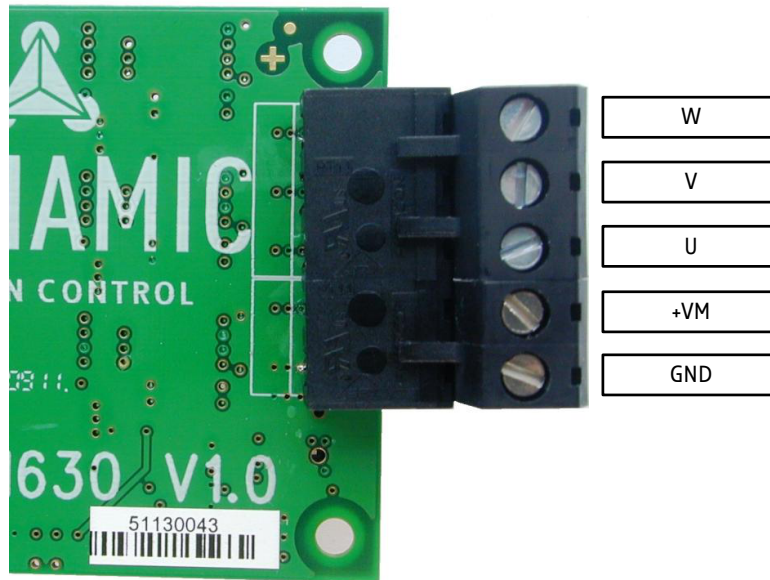

Figure 3: TMCM-1633 Connector

The signals are connected 1:1 to the signals with the same label on the double-row power supply and motor connector on the bottom side of the unit (see Figure 2). Please note that the "power supply and motor connector" on the bottom of the PCB is still required in case the Hall sensor inputs will be used.

Connector type on-board	Mating connector type
RIA AKL 330-05 5pin, 5.0mm pitch header connector	1x RIA AKL 349-05 5pin, 5.0mm pitch detachable screw connector (combined power supply and motor) or 1x RIA AKL 349-02 2pin, 5.0mm pitch detachable screw connector for power supply input (+VM and GND) and 1x RIA AKL 349-03 3pin, 5.0mm pitch detachable screw connector for motor coil connection (U, V, W)

Table 4: Connector type and mating connector for the high current connector option



4.1 Power Supply and Motor Connector

A double row 26pin header with 2.54mm pitch is used for connecting all motor related signals and power supply input.

Pin	Label	Description	Pin	Label	Description
1	W	Motor coil W	2	W	Motor coil W
3	W	Motor coil W	4	W	Motor coil W
5	V	Motor coil V	6	V	Motor coil W
7	V	Motor coil V	8	V	Motor coil W
9	U	Motor coil U	10	U	Motor coil U
11	U	Motor coil U	12	U	Motor coil U
13	VM	Supply input (positive)	14	VM	Supply input (positive)
15	VM	Supply input (positive)	16	VM	Supply input (positive)
17	GND	Supply input (power supply and signal ground)	18	GND	Supply input (power supply and signal ground)
19	GND	Supply input (power supply and signal ground)	20	GND	Supply input (power supply and signal ground)
21	GND	Supply input (power supply and signal ground)	22	GND	Supply input (power supply and signal ground)
23	GND	+5V output (100mA max.) for encoder and / or hall sensor supply	24	Hall3	Hall sensor 3 (+5V TTL or open-collector) signal input
25	Hall1	Hall sensor 1 (+5V TTL or open-collector) signal input	26	Hall2	Hall sensor 2 (+5V TTL or open-collector) signal input

Table 5: Power Supply and Motor Connector pin assignment

NOTICE

Do not connect or disconnect motor during operation! Motor cable and motor inductivity might lead to voltage spikes when the motor is (dis)connected while energized. These voltage spikes might exceed voltage limits of the driver MOSFETs and might permanently damage them. Therefore, always switch off / disconnect power supply or at least disable driver stage before connecting / disconnecting motor.

NOTICE

There is no reverse polarity protection at the supply input!

The module will short any reversed supply voltage and board electronics might get damaged.



4.1.1 Power supply requirements

The power supply should be able to deliver the required power and keep the supply voltage stable at the desired maximum motor current. In no case should the supply voltage exceed the upper or lower voltage limits. In order to be able to cope with high voltage spikes which might be caused by energy fed back from the motor during deceleration a sufficient power supply capacitor should be added on the baseboard close to the module. Depending on the motor and motor current please use a 4700uF or larger capacitor with suitable voltage rating. Additionally, a suitable suppressor diode might be useful.

4.2 I/O, Interface and Encoder Connector

A double row 26pin header with 2.54mm pitch is used for connecting all GPIO, communication (CAN + RS232) and encoder signals.

Pin	Label	Description	Pin	Label	Description
1	+5V	+5V analog reference as used by the internal ADC. Max. load 0.5mA	2	Velocity	Analog input (0-10V), may be used for velocity control in stand-alone mode
3	Torque	Analog input (0-10V), may be used for torque / max. motor current control in stand-alone mode	4	GND	Supply input (power supply and signal ground)
5	Dir_IN	Digital input (+5V TTL). On-board 10k pull-up resistor to +5V. May be used as direction input signal in stand-alone mode	6	Tacho	Digital output (open-drain). May be used as tacho signal output - e.g. toggles on each hall sensor change
7	Stop_IN	Digital input (+5V TTL). On-board 10k pull-up resistor to +5V. May be used as stop input signal in stand-alone mode	8	LED-Temp	Digital output (open-drain). Toggling with approx. 3Hz when temperature pre-warning is exceeded. Output will be permanently pulled low in case of overtemperature of the driver stage
9	LED-CurLim	Digital output (open-drain). Will be pulled low in case current limit has been reached	10	+5V	+5V output (100mA max.) for encoder and / or hall sensor supply
11	GND	Power supply and signal ground	12	GND	Power supply and signal ground
13	Enc_A+	Encoder A channel (non-inverting)	14	Enc_A-	Encoder A channel (inverting)
15	Enc_B+	Encoder B channel (non-inverting)	16	Enc_B-	Encoder B channel (inverting)
17	Enc_N+	Encoder N+ channel (non-inverting)	18	Enc_N-	Encoder N channel (inverting)
19	CAN_L	CAN bus signal (inverting)	20	RS232_RXD	RS232 receive data input
21	CAN_H	CAN bus signal (non-inverting)	22	RS232_TXD	RS232 transmit data output



Pin	Label	Description	Pin	Label	Description
23	n.c.	not connected / do not connect	24	n.c.	not connected / do not connect
25	GND	Power supply and signal ground	26	GND	Power supply and signal ground

Table 6: I/O, Interface and Encoder Connector pin assignment

4.2.1 Reset the module to factory defaults

In order to reset the module to factory default values please follow instructions listed below:

1. Switch off power cycle
2. Short input signal RS232_RXD with output signal RS232_TXD
3. Switch on power supply and wait some time
4. Switch off power supply
5. Remove short circuit

4.2.2 Inputs

The TMC-1633 offers two analog and two digital inputs. The four inputs are available at the 2x13pin "IO, interface and encoder" connector.

Pin	Label	Type	Description
2	Velocity	analog	Either general purpose analog input (0-10V signal) or optional velocity control input in stand alone mode
3	Torque	analog	Either general purpose analog input (0-10V signal) or optional torque control / motor max. current input in stand alone mode
5	Dir_IN	digital	Either general purpose digital input (+5V TTL compatible, internal 10k pull-up to +5V) or optional direction input in stand-alone mode.
7	Stop_IN	digital	Either general purpose digital input (+5V TTL compatible, internal 10k pull-up to +5V) or optional emergency stop input in stand-alone mode.



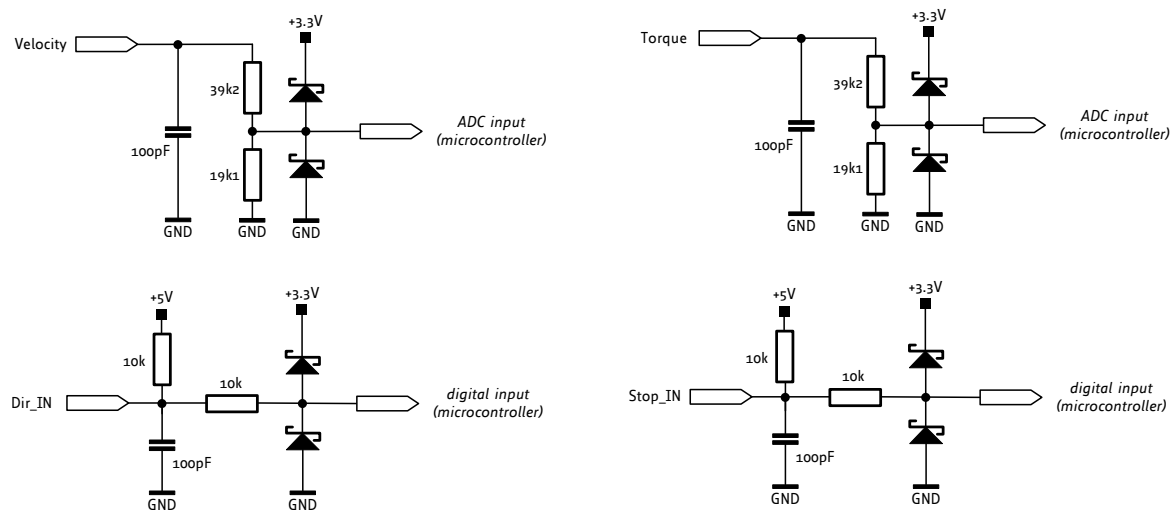

Figure 4: TMCM-1633 input circuit for the general purpose analog and digital inputs

4.2.3 Encoder inputs

The encoder input supports differential, +5V TTL push-pull and open-drain encoder A/B/N signals. As line receiver for differential encoder signals a standard AM26C32 differential line receiver is used.

Pin	Label	Description
13	Enc_A+	Encoder A channel differential non-inverting input. Maybe used for single ended (either TTL +5V push-pull or open-drain) channel A encoder signals, also. Please note: for non-differential signals on-board termination resistors might have to be removed
14	Enc_A-	Encoder A channel differential inverting input
15	Enc_B+	Encoder B channel differential non-inverting input. Maybe used for single ended (either TTL +5V push-pull or open-drain) channel B encoder signals, also. Please note: for non-differential signals on-board termination resistors might have to be removed
16	Enc_B-	Encoder B channel differential non-inverting input
17	Enc_N+	Encoder Null / Zero channel differential non-inverting input. Maybe used for single ended (either TTL +5V push-pull or open-drain) channel N encoder signals, also. Please note: for non-differential signals on-board termination resistors might have to be removed
18	Enc_N-	Encoder N channel differential inverting input



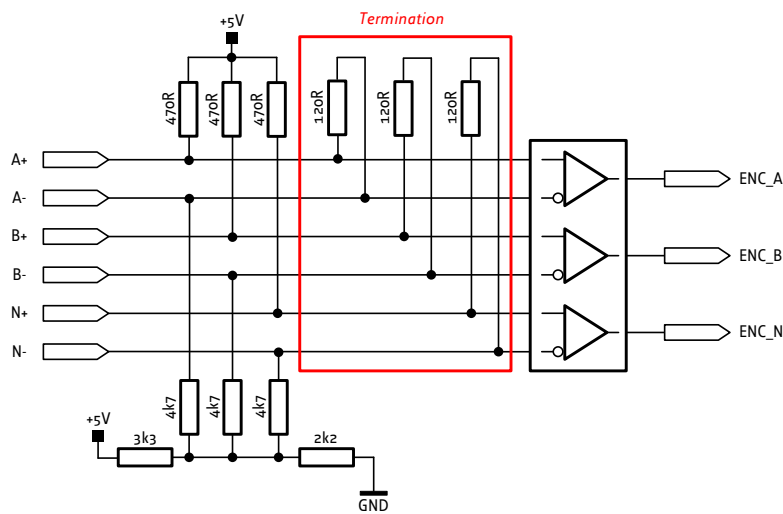

Figure 5: TMCM-1633 encoder input circuit

The TMCM-1633 does include 120R termination resistors for differential encoder signals. In case encoder with single ended +5V TTL push-pull or open-drain signals are used either a level converter should be inserted or it might be necessary to remove the line termination resistors. Please see figure 6 for location of resistor array.

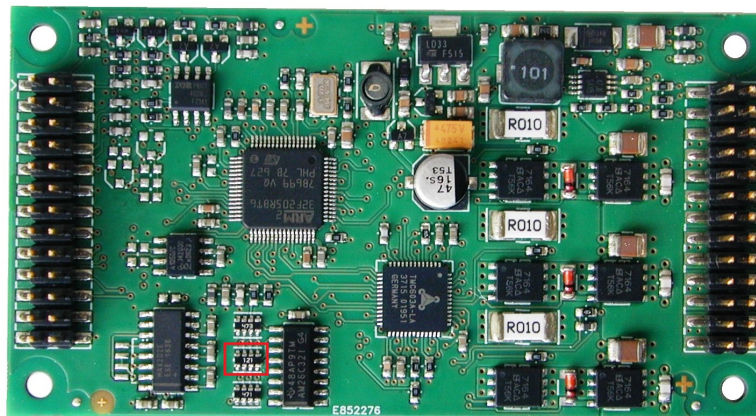

Figure 6: TMCM-1633 encoder termination resistor array (marked red)

4.2.4 Outputs

The TMCM-1633 offers three open-drain outputs. Two of them (*LED-Temp* and *LED-Curlim*) are connected to on-board LEDs, in addition. Please refer to chapter 5 on page 14, also.

Pin	Label	Description
6	Tacho	This open-drain output can sink a maximum of 1A when switched on. It may be used as general purpose output or tacho signal output, i.e. toggles on each hall sensor change.



Pin	Label	Description
8	LED-Temp	This open-drain output can sink a maximum of 1A when switched on. It will toggle with approx. 3Hz when temperature pre-warning threshold has been exceeded and will go permanently low in case of overtemperature of the driver stage.
9	LED-Curlim	This open-drain output can sink a maximum current of 1A when switched on. It will go in case current limit of the driver stage (programmable) has been reached.

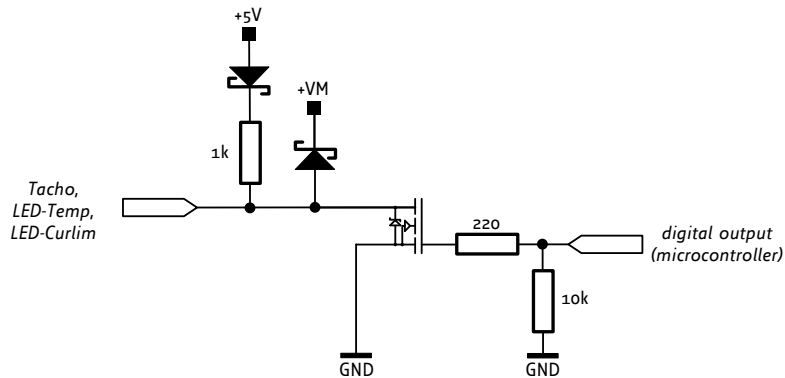

Figure 7: TMCM-1633 output circuit (same circuit design for Tacho, LED-Temp and LED-Curlim outputs)



5 Status LEDs

The TMCM-1633 offers four on-board LEDs for power, error indication, current overload and temperature warning. The LEDs are placed on the back side of the unit. This way they will be still visible when the unit is plugged onto a baseboard.

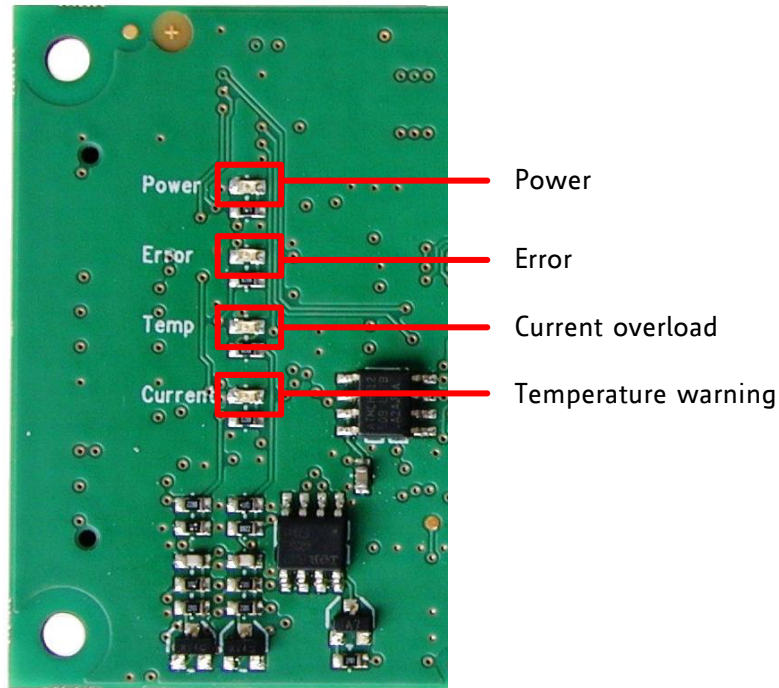

Figure 8: TMCM-1633 LEDs

LED	Color	Description	
Power	green	LED is ON, if the on-board +5V are available	
Error	red	LED is ON in case of error	
Current overload	red	Flash	The current limit LED flashes upon undervoltage switch off
		ON/Flash	Motor PWM is reduced as the motor current limit is exceeded
Temperature warning	red	Flash	Driver stage temperature has exceeded pre-warning threshold (100°C)
		ON	Driver stage temperature has exceeded 125°C. Driver stage will be switched off until temperature falls below 125°C.

Table 10: LED state description



6 Functional Description

The TMCM-1633 is a highly integrated single axis controller/driver module for brushless DC motors (BLDC) with RS232 and CAN interface and support for CANopen. The unit (size: 50mm x 92.5mm) has been designed in order to be plugged onto a baseboard. It offers hall sensor (TTL or open-drain) and encoder (incremental a/b/n) inputs.

In Figure 9 the main parts of the TMCM-1633 are shown:

- Microcontroller, responsible for overall control and 3-phase pwm generation
- Pre-driver (based on TMC603)
- power MOSFET driver bridge
- current measurement via three (low-side) shunts
- Encoder and hall sensor interfaces
- digital inputs and outputs
- CAN™ interface

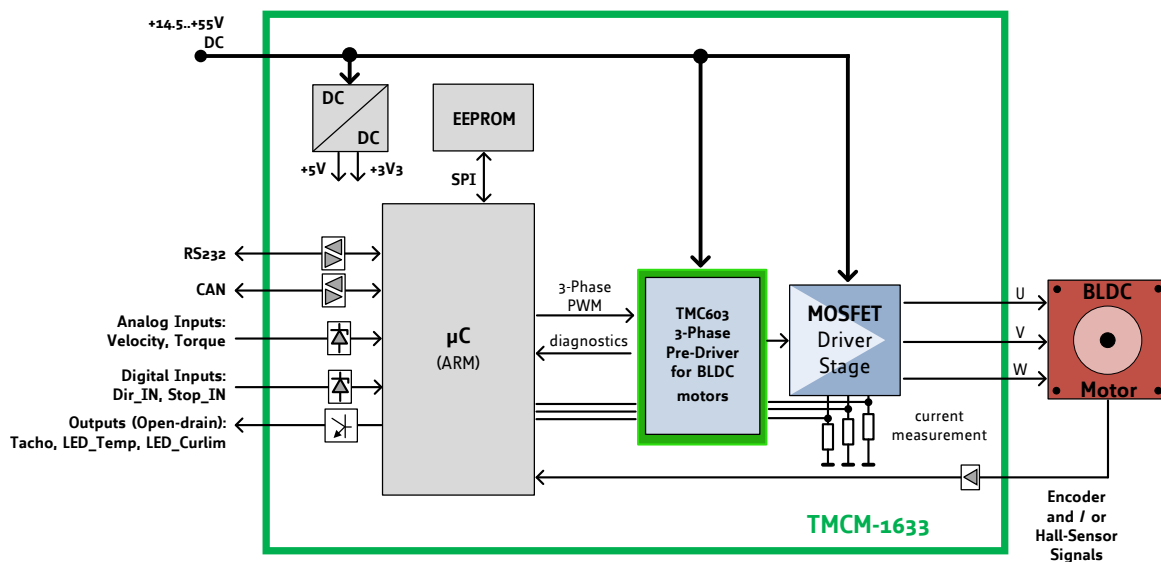

Figure 9: TMCM-1633 block diagram



7 Operational Ratings and Characteristics

7.1 Absolute Maximum Ratings

Symbol	Parameter	Min	Typ	Max	Unit
V_S	Power supply voltage for operation	14.5	24, 48	50	V
I_S	Power supply current	0.04		I_{MOT}	A
P_{ID}	Module idle power consumption		1.2		W
I_{+5V}	+5V output for supply of external circuits (e.g. encoder and / or hall sensors)			100	mA
I_{MC}	Continuous motor current at max. supply voltage		0 - 8	10	A
I_{MP}	Short time motor current e.g. during acceleration periods		0 - 10		A
V_{DIGI}	Input voltage on general purpose and hall sensor digital inputs	-0.3		+5.3V	V
I_O	Sink current on digital outputs (open-drain current)			1	A
V_{ANA}	Analog input voltage	0	0 - 10	24	V
f_{CHOP}	Chopper frequency		20		kHz
T_0	Environmental temperature for operation at max specified motor current (air flow might be required, depending on motor / voltage)	-25		+60	°C
T_{board}	Temperature of the module as measured by the on-board sensor (NTC)		<100	125	°C

Table 11: TMCM-1633 Operational Ratings

NOTICE

Never Exceed the absolute maximum ratings! Keep the power supply voltage below the upper limit of +50V! Otherwise the board electronics will seriously be damaged! Especially, when the selected operating voltage is near the upper limit a regulated power supply is highly recommended.



8 Abbreviations used in this Manual

Abbreviation	Description
BLDC	Brushless DC
FOC	Field Oriented Control
IDE	Integrated Development Environment
LED	Light Emmitting Diode
RMS	Root Mean Square value
TMCL	TRINAMIC Motion Control Language

Table 12: Abbreviations used in this Manual



9 Figures Index

1	TMCM-1633 mechanical dimensions .	5	6	TMCM-1633 encoder termination resistor array (marked red)	12
2	TMCM-1633 Connector	6	7	TMCM-1633 output circuit (same circuit design for Tacho, LED-Temp and LED-Curlim outputs)	13
3	TMCM-1633 Connector	7	8	TMCM-1633 LEDs	14
4	TMCM-1633 input circuit for the general purpose analog and digital inputs	11	9	TMCM-1633 block diagram	15
5	TMCM-1633 encoder input circuit . .	12			



10 Tables Index

1	Order code module	4	6	I/O, Interface and Encoder Connector pin assignment	10
2	TMCM-1633size and weight	5	10	LED state description	14
3	Connector type and mating connector of the TMCM-1633	6	11	TMCM-1633 Operational Ratings	16
4	Connector type and mating connector for the high current connector option	7	12	Abbreviations used in this Manual	17
5	Power Supply and Motor Connector pin assignment	8	13	Hardware Revision	22
			14	Document Revision	22



11 Supplemental Directives

11.1 Producer Information

11.2 Copyright

TRINAMIC owns the content of this user manual in its entirety, including but not limited to pictures, logos, trademarks, and resources. © Copyright 2021 TRINAMIC. All rights reserved. Electronically published by TRINAMIC, Germany.

Redistributions of source or derived format (for example, Portable Document Format or Hypertext Markup Language) must retain the above copyright notice, and the complete Datasheet User Manual documentation of this product including associated Application Notes; and a reference to other available product-related documentation.

11.3 Trademark Designations and Symbols

Trademark designations and symbols used in this documentation indicate that a product or feature is owned and registered as trademark and/or patent either by TRINAMIC or by other manufacturers, whose products are used or referred to in combination with TRINAMIC's products and TRINAMIC's product documentation.

This Hardware Manual is a non-commercial publication that seeks to provide concise scientific and technical user information to the target user. Thus, trademark designations and symbols are only entered in the Short Spec of this document that introduces the product at a quick glance. The trademark designation /symbol is also entered when the product or feature name occurs for the first time in the document. All trademarks and brand names used are property of their respective owners.

11.4 Target User

The documentation provided here, is for programmers and engineers only, who are equipped with the necessary skills and have been trained to work with this type of product.

The Target User knows how to responsibly make use of this product without causing harm to himself or others, and without causing damage to systems or devices, in which the user incorporates the product.

11.5 Disclaimer: Life Support Systems

TRINAMIC Motion Control GmbH & Co. KG does not authorize or warrant any of its products for use in life support systems, without the specific written consent of TRINAMIC Motion Control GmbH & Co. KG.

Life support systems are equipment intended to support or sustain life, and whose failure to perform, when properly used in accordance with instructions provided, can be reasonably expected to result in personal injury or death.

Information given in this document is believed to be accurate and reliable. However, no responsibility is assumed for the consequences of its use nor for any infringement of patents or other rights of third parties which may result from its use. Specifications are subject to change without notice.

11.6 Disclaimer: Intended Use

The data specified in this user manual is intended solely for the purpose of product description. No representations or warranties, either express or implied, of merchantability, fitness for a particular purpose



or of any other nature are made hereunder with respect to information/specification or the products to which information refers and no guarantee with respect to compliance to the intended use is given.

In particular, this also applies to the stated possible applications or areas of applications of the product. TRINAMIC products are not designed for and must not be used in connection with any applications where the failure of such products would reasonably be expected to result in significant personal injury or death (safety-Critical Applications) without TRINAMIC's specific written consent.

TRINAMIC products are not designed nor intended for use in military or aerospace applications or environments or in automotive applications unless specifically designated for such use by TRINAMIC. TRINAMIC conveys no patent, copyright, mask work right or other trade mark right to this product. TRINAMIC assumes no liability for any patent and/or other trade mark rights of a third party resulting from processing or handling of the product and/or any other use of the product.

11.7 Collateral Documents & Tools

This product documentation is related and/or associated with additional tool kits, firmware and other items, as provided on the product page at: www.trinamic.com.



12 Revision History

12.1 Hardware Revision

Version	Date	Author	Description
1.00	07.11.2016	GE	Initial version based on TMCM-1630-2C V1.1 with more powerful processor for CANopen firmware

Table 13: Hardware Revision

12.2 Document Revision

Version	Date	Author	Description
1.00	10.02.2017	GE	First release based on TMCM-1630 hardware manual.
1.01	07.09.2017	GE	Block diagram corrected

Table 14: Document Revision

