

Hardware Version V 1.1

HARDWARE MANUAL

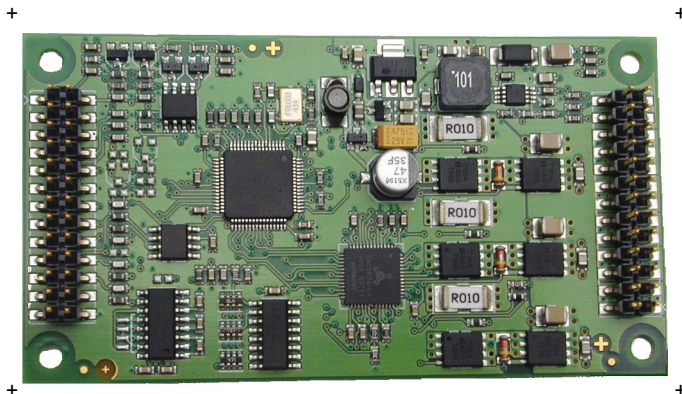

TMCM-1630

1-Axis BLDC
Controller / Driver
plug-in module
10A / 48V DC
RS232 / CAN or
RS485 / USB

TRINAMIC Motion Control GmbH & Co. KG
Hamburg, Germany

www.trinamic.com

Table of contents

1	Life support policy	3
2	Features	4
3	Order codes	5
4	Mechanical and electrical interfacing	6
4.1	Dimensions of the module	6
5	Connectors	7
5.1	Motor and power connector	9
5.1.1	Power supply requirements	9
5.2	Communication, GPIO, and encoder connector	10
5.2.1	Reset the module to factory defaults	10
5.2.2	Inputs	11
5.2.3	Open drain outputs	12
5.2.4	Encoder	13
6	LEDs	14
7	Operational ratings	15
8	Functional description	16
8.1	System architecture	16
8.1.1	Microcontroller	16
8.1.2	TMC6030A pre-driver	16
9	Revision history	17
9.1	Document revision	17
9.2	Hardware revision	17
10	References	17

1 Life support policy

TRINAMIC Motion Control GmbH & Co. KG does not authorize or warrant any of its products for use in life support systems, without the specific written consent of TRINAMIC Motion Control GmbH & Co. KG.

Life support systems are equipment intended to support or sustain life, and whose failure to perform, when properly used in accordance with instructions provided, can be reasonably expected to result in personal injury or death.

© TRINAMIC Motion Control GmbH & Co. KG 2012 - 2021

Information given in this data sheet is believed to be accurate and reliable. However neither responsibility is assumed for the consequences of its use nor for any infringement of patents or other rights of third parties, which may result from its use.

Specifications are subject to change without notice.



2 Features

The TMCM-1630 is a highly integrated single axis BLDC servo controller module with several interface-options. The highly integrated module (size: 50mm x 92.5 mm) has been designed in order to be plugged onto a baseboard. It integrates velocity and position control and offers hall sensor and incremental encoder (a/b/n) inputs. The module can be used in stand alone operation or remote controlled.

Applications

- Demanding single and multi-axis BLDC motor solutions

Electrical data

- Supply voltage: +24V DC or +48V DC nominal (+15... +55V DC max.)
- Motor current: up to 10A RMS (programmable) peak

Integrated motion controller

- High performance ARM Cortex™-M3 microcontroller for system control and communication protocol handling

Integrated motor driver

- High performance integrated pre-driver (TMC603A)
- High-efficient operation, low power dissipation (MOSFETs with low $R_{DS(ON)}$)
- Dynamic current control
- Integrated protection
- On the fly alteration of motion parameters (e.g. position, velocity, acceleration)

Interfaces

- Two standard assembly options:
 - RS232 and CAN (2.0B up to 1Mbit/s)
 - RS485 and USB (High-speed 12Mbit/s)
- 2 analogue and 2 digital inputs
- 3 open drain outputs

Motor type

- Block commutated 3 phase BLDC motors with optional hall sensors / optional encoder
- Motor power from a few Watts to nearly 500W
- Motor velocity up to 100,000 RPM (electrical field)
- Common supply voltages of 12V DC, 24V DC, 36V DC and 48V DC supported
- Coil current up to 10A peak

Software

- TMCL™ stand-alone operation or remote controlled operation
- TMCL™ program memory (non volatile) for up to 2048 TMCL™ commands
- TMCL™ PC-based application development software TMCL-IDE and TMCL-BLDC available for free
- CANopen: for CANopen support please consider using the TMCM-1633

Other

- Two double-row 2.54mm connectors
- ROHS compliant
- Size: 50x92.5mm²

Please see separate TMCL™ Firmware Manual for additional information

3 Order codes

Order code	Description	Dimensions [mm]
TMCM-1630-4U-TMCL	Single axis BLDC plug-in servo controller module with RS485 interface, USB interface and TMCL™ firmware	50 x 92.5 x 14*
TMCM-1630-2C-TMCL	Single axis BLDC plug-in servo controller module with RS232 interface, CAN interface, and TMCL™ firmware	50 x 92.5 x 14*

* Module height (14mm) including connectors

Table 3.1: Order codes

4 Mechanical and electrical interfacing

4.1 Dimensions of the module

The module has a size of 92.5mm x 50mm. It offers four mounting holes (diameter: 3.2mm). Maximum overall height of the module including connectors: approx. 14mm.

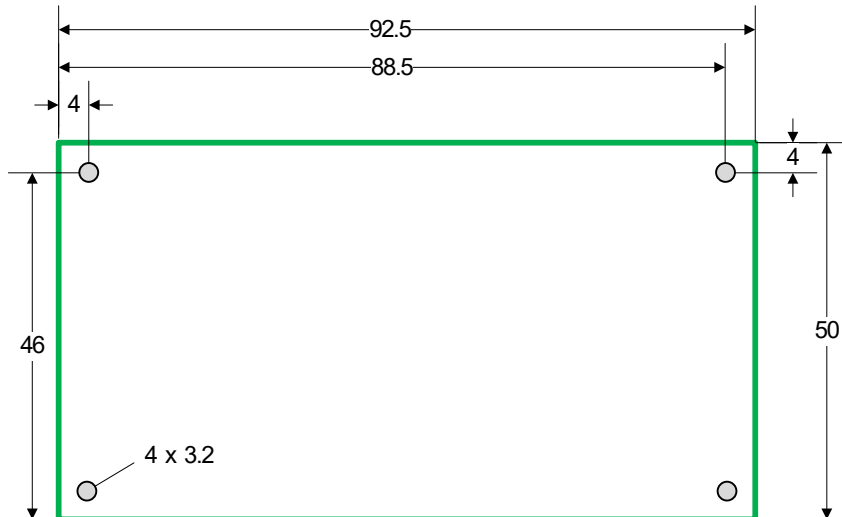

Figure 4.1: Size of module

5 Connectors

The module offers two double row 2.54mm pitch standard connectors, one at each end of the board.

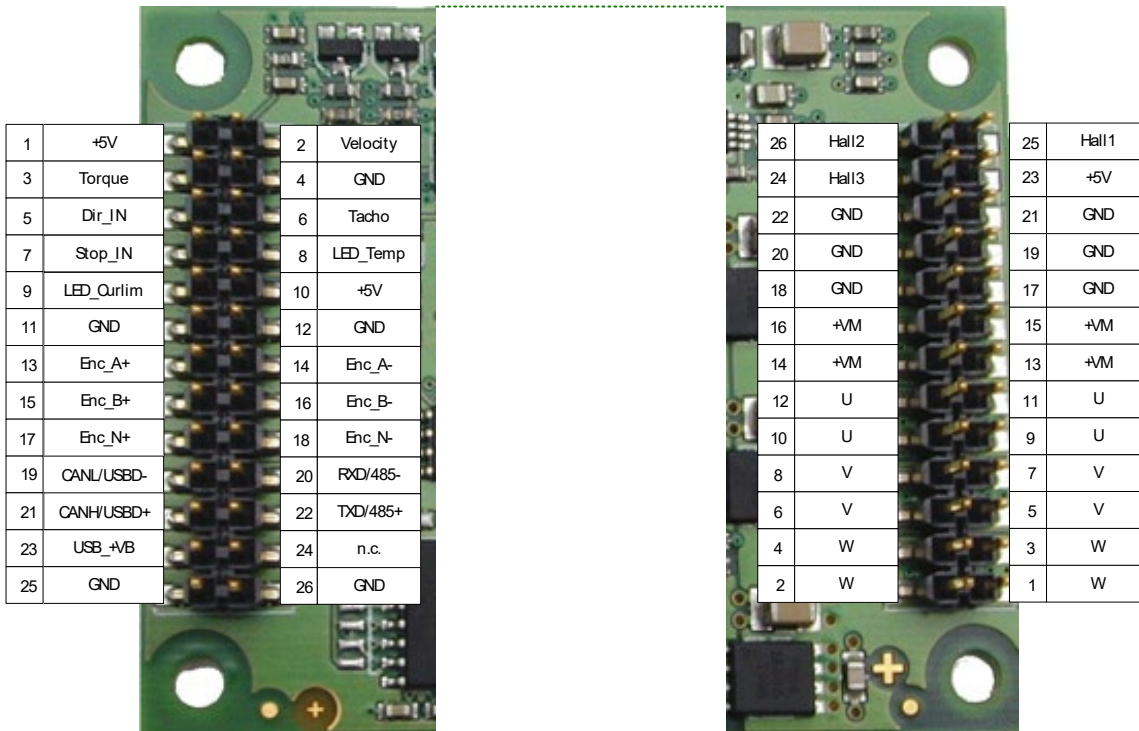

Figure 5.1: Connectors

Domain	Connector type	Mating connector type
I/Os, interfaces, encoder	TSM-113-03-L-DV-K-A, 2x13 poles, double row, 2.54mm pitch, SMD vertical, Samtec	SSW, SSQ, SSM, BSW, ESW, ESQ, BCS, SLW, CES, HLE , IDSS and IDSD series, Samtec
Power, motor	TSM-113-03-L-DV-K-A, 2x13 poles, double row, 2.54mm pitch, SMD vertical, Samtec	SSW, SSQ, SSM, BSW, ESW, ESQ, BCS, SLW, CES, HLE , IDSS and IDSD series, Samtec

Table 5.1: Connector type and mating connector of the TMCM-1630

Since the two connectors of the TMCM-1630 are similar be careful not to plug-in the module the other way round. Also, be sure to place the connectors exactly to their mating opponents. Not following these guidelines might cause permanent damage to the module when turning power supply on.

Especially for higher motor currents the module offers an assembly option for a detachable screw connector which will be assembled on the top side of the board. The 5 pin connector offers power supply (+VM and GND) and motor coil (U, V, W) connections:

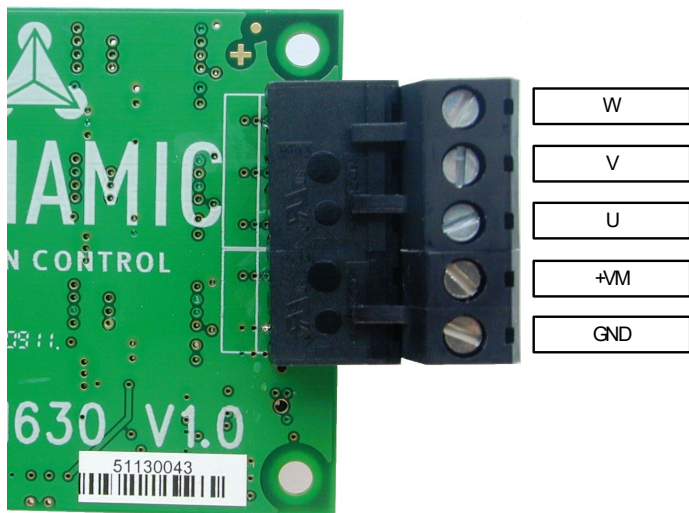

Figure 5.2: Additional detachable screw connector as assembly option

The signals are connected 1:1 to the signals with the same label on the two-row motor and power connector header on the bottom side of the board.

Connector type assembled on board	Mating connector type
RIA AKL 330-05 5pin, 5.0mm pitch connector	1x RIA AKL 349-05 5pin, 5.0mm pitch screw connector <u>or</u> 1x RIA AKL 349-02 2pin, 5.0mm pitch screw connector for power supply (+VM and GND) and 1x RIA AKL 349-03 3pin 5.0mm pitch screw connector for motor coil connection (U, V, W)

Table 5.2: Connector type and mating connector of the detachable screw connector

5.1 Motor and power connector

A double row 26 pin header with 2.54mm pitch is used for connecting all motor related signals and module power supply.

Pin	Label	Description	Pin	Label	Description
1	W	Motor coil W	2	W	Motor coil W
3	W	Motor coil W	4	W	Motor coil W
5	V	Motor coil V	6	V	Motor coil V
7	V	Motor coil V	8	V	Motor coil V
9	U	Motor coil U	10	U	Motor coil U
11	U	Motor coil U	12	U	Motor coil U
13	VM	Module driver supply voltage	14	VM	Module driver supply voltage
15	VM	Module driver supply voltage	16	VM	Module driver supply voltage
17	GND	Module ground (power supply and signal ground)	18	GND	Module ground (power supply and signal ground)
19	GND	Module ground (power supply and signal ground)	20	GND	Module ground (power supply and signal ground)
21	GND	Module ground (power supply and signal ground)	22	GND	Module ground (power supply and signal ground)
23	+5V	+5V output (100mA max.) for encoder and/or hall sensor supply	24	HALL3	Hall sensor 3 signal input, +5V compatible. Accepts either +5V TTL or open-drain signals (internal 10k pull-up resistor to +5V)
25	HALL1	Hall sensor 1 signal input, +5V compatible. Accepts either +5V TTL or open-drain signals (internal 10k pull-up resistor to +5V)	26	HALL2	Hall sensor 2 signal input, +5V compatible. Accepts either +5V TTL or open-drain signals (internal 10k pull-up resistor to +5V)

Table 5.3: Connector for motor related signals and power supply

5.1.1 Power supply requirements

The power supply should be designed in a way, that it supplies the nominal motor voltage at the desired maximum motor current. In no case shall the supply voltage exceed the upper or lower voltage limits. To be able to cope with high voltage spikes which might be caused by energy fed back from the motor during deceleration, a sufficient power supply capacitor should be added on the baseboard closed to the module. Depending on the motor and expected motor current please use a 4700 μ F or larger capacitor with suitable voltage rating. Additionally, a suitable suppressor (zener-) diode might be useful.

5.2 Communication, GPIO, and encoder connector

A double row 26 pin header with 2.54mm pitch is used for connecting all communication and GPIO signals.

Pin	Label	Description	Pin	Label	Description
1	+5V	5V analog reference as used by the internal DAC. Max. load 0.5mA	2	Velocity	Used for velocity control in stand alone operation by supplying external 0 – 10V signal
3	Torque	Used for max. motor current / torque control in stand alone operation by supplying external 0-10V signal	4	GND	Module ground (power supply and signal ground)
5	Dir_IN	5V TTL input. Tie to GND to inverse motor direction, leave open or tie to 5V otherwise.	6	Tacho	This pin outputs a tacho impulse, i.e. toggles on each hall sensor change
7	Stop_IN	Emergency stop. Tie this pin to GND to stop the motor (same as the <i>Motor Off</i> switch on PCB). The motor can be restarted via the interface, or by cycling the power supply	8	LED-Temp	5V TTL output: Toggling with 3Hz when temperature pre-warning threshold is exceeded, high when module shut down due to overtemperature
9	LED-Curlim	High, when module goes into current limiting mode	10	+5V	5V output as reference for external purpose
11	GND	GND reference	12	GND	GND reference
13	Enc_A+	Encoder A+ channel	14	Enc_A-	Encoder A- channel
15	Enc_B+	Encoder B+ channel	16	Enc_B-	Encoder B- channel
17	Enc_N+	Encoder N+ channel	18	Enc_N-	Encoder N- channel
19	CANL/USBD-	CAN low / USB D- bus line *)	20	RXD/485-	RXD signal for RS232 / inverting signal for RS485
21	CANH/USBD+	CAN high / USB D+ bus line *)	22	TXD/485+	TXD signal for RS232 / non inverting signal for RS485
23	USB_+VB	Use to detect availability of attached host system (e.g. PC)	24	n.c.	
25	GND	GND reference	26	GND	GND reference

Table 5.4: Connector for communication and GPIOs

*) Please note: USB interfaces do not provide the same level of robustness and noise immunity as fieldbus interfaces (CAN, RS485 etc.). Therefore, USB is not recommended as primary communication interface for production use in industrial or electrically noisy environments.

5.2.1 Reset the module to factory defaults

Interface	Description
RS232	Short RxD and TxD for resetting the module.
USB	Use your USB interface for resetting the module with the functions of TMCL-IDE. Please refer to the TMCL™ Firmware Manual.

Table 5.5: Reset the module to factory defaults

5.2.2 Inputs

The TMCM-1630 offers two analogue and two digital inputs.

Pin	Label	analogue/digital	Description
2	Velocity	analogue	Used for velocity control in stand alone operation by supplying external 0 – 10V signal
3	Torque	analogue	Used for max. motor current / torque control in stand alone operation by supplying external 0 – 10V signal
5	Dir_IN	digital	Direction input (+5V TTL compatible). Tie to GND to inverse motor direction, leave open or tie to +5V otherwise.
7	Stop_IN	digital	Emergency stop. Tie this pin to GND to stop the motor. The motor can be restarted via the interface, or by cycling the power supply

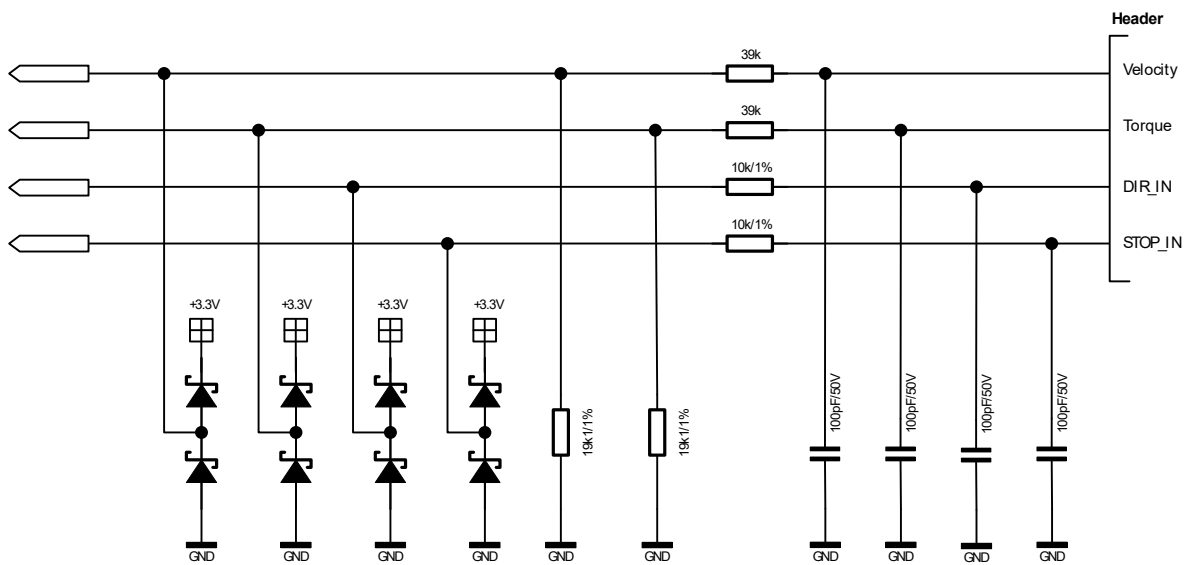

Figure 5.3: Internal circuit of analogue and digital inputs

5.2.3 Open drain outputs

The module offers three open drain outputs. Two of them (*LED-Temp* and *LED-Curlim*) power on-board LEDs, also. Please refer to paragraph 6 for more information about the LEDs.

Pin	Label	Description
6	Tacho	This pin outputs a tacho impulse, i.e. toggles on each hall sensor change
8	LED-Temp	+5V TTL output: Toggling with 3Hz when temperature pre-warning threshold is exceeded, low when module shut down due to overtemperature
9	LED-Curlim	Low when module goes into current limiting mode

Table 5.6: Outputs of the TMCM-1630

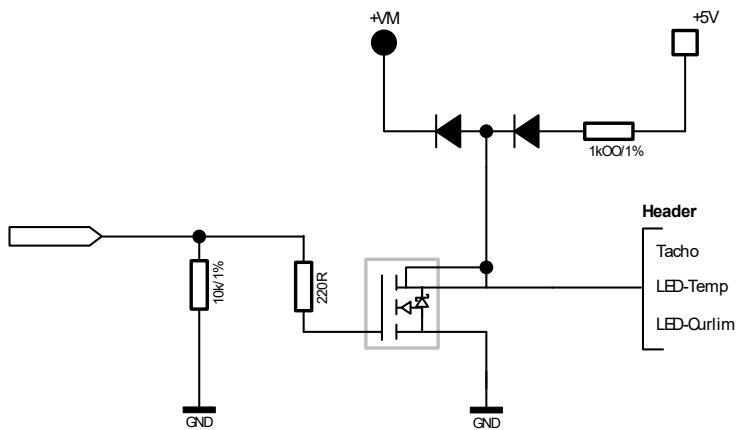

Figure 5.4: Internal circuit of the outputs

5.2.4 Encoder

Pin	Label	Description
13	Enc_A+	Encoder A+ channel
14	Enc_A-	Encoder A- channel
15	Enc_B+	Encoder B+ channel
16	Enc_B-	Encoder B- channel
17	Enc_N+	Encoder N+ channel
18	Enc_N-	Encoder N- channel

Table 5.7: Encoder channels of TMCM-1630

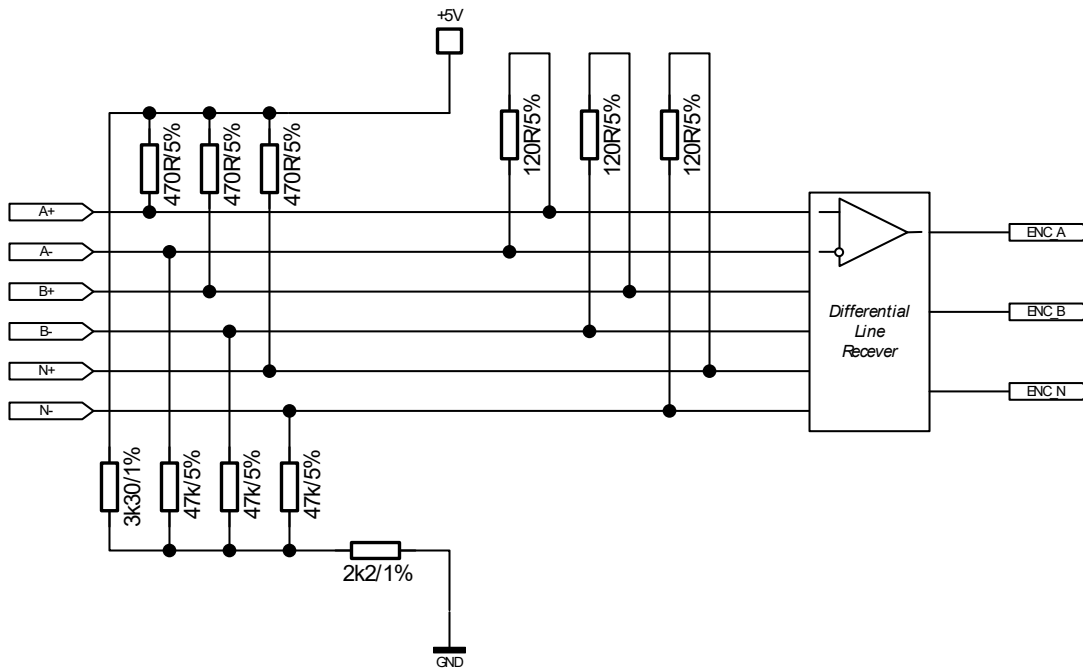

Figure 5.5: Internal circuit of the encoder channels

6 LEDs

The TMCM-1630 module has 4 on-board LEDs for power, error indication, current overload, and temperature warning. The LEDs are placed on the back of the module. You can plug the module on its baseboard and take a look at the LEDs on the backside of the module.

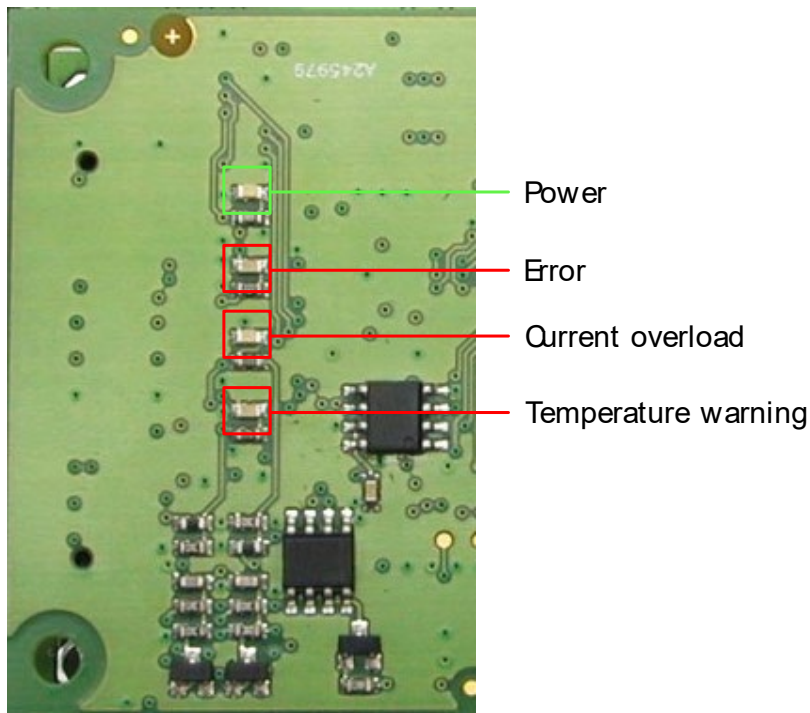

Figure 6.1: On-board LEDs

LED	Color	Description	
Power	green	LED is ON, if the on-board +5V are available	
Error	red	ON in case of error	
Current overload	red	Blink	The current limit LED blinks upon under voltage switch off
		ON/Flicker	Motor PWM is reduced due to exceeding the set motor current limit
Temperature warning	red	Blink	The power stage on the module has exceeded a critical temperature of 100°C (Pre-warning)
		ON	The power stage on the module has exceeded the critical temperature of 125°C. The motor becomes switched off, until temperature falls below 115°C. The measurement is correct to about +/-10°C

Table 6.1: LEDs signals and their meaning

7 Operational ratings

The operational ratings show the intended/the characteristic range for the values and should be used as design values. An operation within the limiting values is possible, but shall not be used for extended periods, because the unit life time may be shortened. In no case shall the limiting values be exceeded.

Symbol	Parameter	Min	Typ	Max	Unit
V_S	Power supply voltage for operation	15	24, 48	55	V
I_S	Power supply current	0.04		I_{MOT}	A
P_{ID}	Module idle power consumption		1.2		W
V_S	5 Volt (+-8%) output external load (hall sensors plus other load)			100	mA
I_{MC}	Continuous Motor current at V_{MF}		0 – 8	10	A
I_{MP}	Short time Motor current in acceleration periods		0 – 10		A
V_I	Logic input voltage on digital / hall sensor inputs	-0.3		$V_{CC}+$ 0.3	V
I_O	Sink current on digital outputs (open-drain outputs)			1	A
V_{IA}	Analog input voltage	-24	0 – 10	24	V
f_{CHOP}	Chopper frequency		20		kHz
E_x	Exactness of voltage and current measurement	-8		+8	%
T_{SL}	Motor output slope (U, V, W)		100		ns
T_O	Environment temperature operating	-25		+70	°C
T_{OF}	Environment temperature for operation at full specified current (air flow required, depending upon motor / voltage)	-25		+60	°C
T_{board}	Temperature of the module, as measured by the integrated sensor.		<100	125	°C

Table 7.1: Operational ratings

8 Functional description

In figure 8.1 the main parts of the TMCM-1630 module are shown. The module mainly consists of the Cortex™-M3 CPU, TRINAMICs highly integrated TMC603 BLDC motor pre-driver, the MOSFET driver stage, different interfaces (depends up-on which option you have chosen), the inputs, and the outputs (open drain).

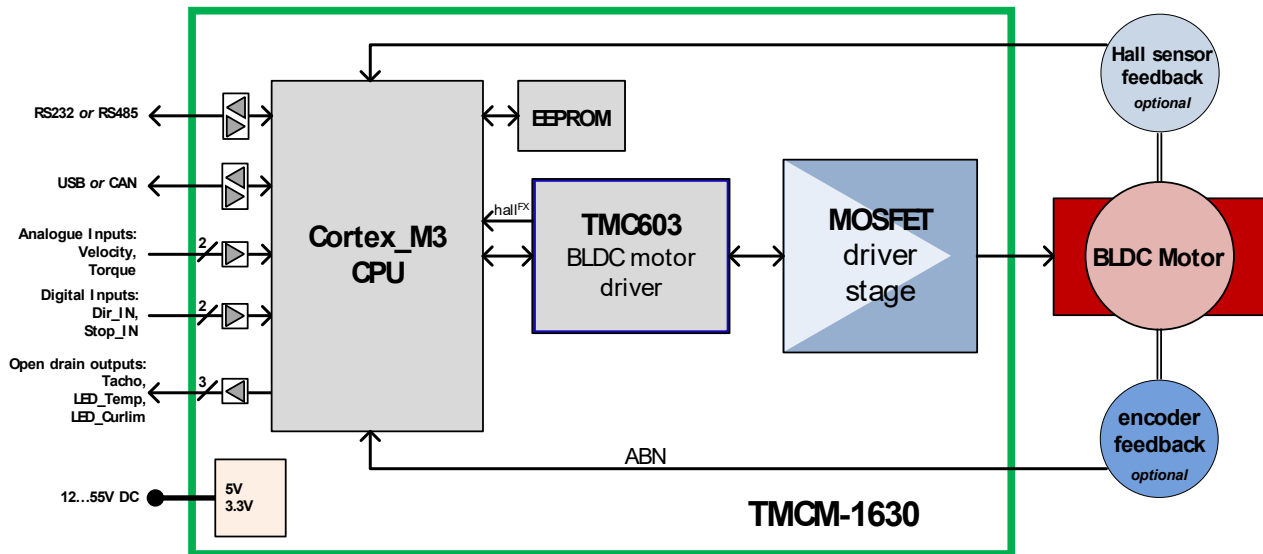

Figure 8.1: Main parts of the TMCM-1630

8.1 System architecture

The TMCM-1630 integrates a microcontroller with the TMCL™ Firmware or CANopen. The motion control real-time tasks are realized by the TMC603A.

8.1.1 Microcontroller

On this module, the ARM Cortex-M3™ CPU 32-bit processor is used to run the TMCL™ operating system and to control the TMC603A. The flash memory of the microcontroller holds the TMCL™ operating system. The EEPROM memory is used to permanently store configuration data. The microcontroller runs the TMCL™ or CANopen operating system which makes it possible to execute commands that are sent to the module from the host via the interface. The microcontroller interprets the commands and controls the TMC603A.

The TMCL™ operating system can be updated via the host interface. Please use the latest version of the TMCL-IDE to do this.

8.1.2 TMC603A pre-driver

The TMC603A is a three phase motor driver for highly compact and energy efficient drive solutions. It contains all power and analog circuitry required for a high performance BLDC motor system. The TMC603A is designed to provide the frontend for a microcontroller doing motor commutation and control algorithms. Protection and diagnostic features as well as a step down switching regulator reduce system cost and increase reliability.

9 Revision history

9.1 Document revision

Version	Date	Author	Description
1.00	2011-JUN-02	SD	Initial version
1.01	2011-NOV-07	SD	Minor changes
1.02	2012-JUN-11	SD	Hall signal description (connector) corrected.
1.03	2012-JUL-03	GE	Assembly option for 5pin detachable screw connector for power and motor coil connection on top side of module added.
1.04	2018-JAN-15	GE	Minor changes: <ul style="list-style-type: none"> Note on sensorless operation (hallFX™) removed Note on CANopen support under development removed (see TMCM-1633 for CANopen support) Several Updates / corrections
1.05	2018-JUN-25	GE	Minor changes: <ul style="list-style-type: none"> Type of document corrected: "Module for BLDC Motors" Document property title changed to TMCM-1630 Hardware Manual
1.06	2019-APR-03	GE	Changes: <ul style="list-style-type: none"> Min operating voltage corrected Hall sensor interface details added
1.07	2021-FEB-01	GE	Note on USB added: not recommended as primary communication interface in harsh / industrial environments

Table 9.1: Document revision

9.2 Hardware revision

Version	Date	Description
V1.0	2011-JAN-19	First version
V1.1	2012-OCT-17	<ul style="list-style-type: none"> Hall sensor input buffer replaced in order to avoid start-up issues with on-board switching regulator under certain conditions Filter circuit for CAN + RS232 removed Label "Current" and "Temp" corrected Minor corrections

Table 9.2: Hardware revision

10 References

[TMCM-1630]	TMCM-1630 TMCL™ Firmware Manual
[BB-1630]	BB-1630 Hardware Manual
[TMCL-IDE]	TMCL-IDE User Manual
[TMCL-BLDC]	TMCL-BLDC User Manual

Please refer to www.trinamic.com.