

RELIABILITY REPORT
FOR
MAX3089
PLASTIC ENCAPSULATED DEVICES

April 18, 2003

MAXIM INTEGRATED PRODUCTS

120 SAN GABRIEL DR.
SUNNYVALE, CA 94086

Written by



Jim Pedicord
Quality Assurance
Reliability Lab Manager

Reviewed by



Bryan J. Preeshl
Quality Assurance
Executive Director

Conclusion

The MAX3089 successfully meets the quality and reliability standards required of all Maxim products. In addition, Maxim's continuous reliability monitoring program ensures that all outgoing product will continue to meet Maxim's quality and reliability standards.

Table of Contents

I.Device Description	V.Quality Assurance Information
II.Manufacturing Information	VI.Reliability Evaluation
III.Packaging Information	
IV.Die InformationAttachments

I. Device Description

A. General

The MAX3089 high-speed transceiver for RS-485/RS-422 communication contains one driver and one receiver. This device features fail-safe circuitry, which guarantees a logic-high receiver output when the receiver inputs are open or shorted. This means that the receiver output will be a logic high if all transmitters on a terminated bus are disabled (high impedance). The MAX3089's slew rate is selectable between 115kbps, 500kbps, and 10Mbps by driving a selector pin with a single three-state driver.

This transceiver typically draws 375 μ A of supply current when unloaded, or when fully loaded with the driver disabled.

This device has a 1/8-unit-load receiver input impedance that allows up to 256 transceivers on the bus. The MAX3089 is selectable between half-duplex and full-duplex operation. It also features independently programmable receiver and transmitter output phase via separate pins.

B. Absolute Maximum Ratings

<u>Item</u>	<u>Rating</u>
Supply Voltage (V_{CC})	+7V
Control Input Voltage (/RE, DE)	-0.3V to ($V_{CC} + 0.3V$)
Special Input Voltage (H/F, SRL, TXP, RXP)	-0.3V to ($V_{CC} + 0.3V$)
Driver Input Voltage (DI)	-0.3V to ($V_{CC} + 0.3V$)
Driver Output Voltage (A,B, Y, Z)	$\pm 13V$
Receiver Input Voltage (A, B)	$\pm 13V$
Receiver Input Voltage, Full Duplex (A, B)	$\pm 25V$
Receiver Output Voltage (RO)	-0.3V to ($V_{CC} + 0.3V$)
Storage Temp.	-65°C to +150°C
Lead Temp. (10 sec.)	+300°C
Continuous Power Dissipation ($T_A = +70^\circ C$)	
14-Pin SO	941mW
14-Pin PDIP	1067mW
Derates above +70°C	
14-Pin SO	11.76mW/°C
14-Pin PDIP	13.33mW/°C

II. Manufacturing Information

- A. Description/Function: Fail-Safe, High-Speed (10Mbps), Slew-Rate-Limited RS-485/RS-422 Transceiver
- B. Process: S3 (Standard 3 micron silicon gate CMOS)
- C. Number of Device Transistors: 631
- D. Fabrication Location: Oregon, USA
- E. Assembly Location: Philippines or Malaysia
- F. Date of Initial Production: March, 1997

III. Packaging Information

- | | | |
|-------------------------|--------------------------|--------------------------|
| A. Package Type: | 14-Lead SO | 14-Lead PDIP |
| B. Lead Frame: | Copper | Copper |
| C. Lead Finish: | Solder Plate | Solder Plate |
| D. Die Attach: | Silver-filled Epoxy | Silver-filled Epoxy |
| E. Bondwire: | Gold (1.3 mil dia.) | Gold (1.3 mil dia.) |
| F. Mold Material: | Epoxy with silica filler | Epoxy with silica filler |
| G. Assembly Diagram: | # 05-1901-0154 | # 05-1901-0153 |
| H. Flammability Rating: | Class UL94-V0 | Class UL94-V0 |

IV. Die Information

- A. Dimensions: 85 x 140 mils
- B. Passivation: $\text{Si}_3\text{N}_4/\text{SiO}_2$ (Silicon nitride/ Silicon dioxide)
- C. Interconnect: Aluminum/Si (Si = 1%)
- D. Backside Metallization: None
- E. Minimum Metal Width: 3 microns (as drawn)
- F. Minimum Metal Spacing: 3 microns (as drawn)
- G. Bondpad Dimensions: 5 mil. Sq.
- H. Isolation Dielectric: SiO_2
- I. Die Separation Method: Wafer Saw

V. Quality Assurance Information

A. Quality Assurance Contacts:

Jim Pedicord (Manager, Rel Operations)
Bryan Preeshl (Executive Director of QA)
Kenneth Huening (Vice President)

B. Outgoing Inspection Level: 0.1% for all electrical parameters guaranteed by the Datasheet.
0.1% For all Visual Defects.

C. Observed Outgoing Defect Rate: < 50 ppm

D. Sampling Plan: Mil-Std-105D

VI. Reliability Evaluation

A. Accelerated Life Test

The results of the 135°C biased (static) life test are shown in **Table 1**. Using these results, the Failure Rate (λ) is calculated as follows:

$$\lambda = \frac{1}{\text{MTTF}} = \frac{1.83}{192 \times 4389 \times 560 \times 2} \quad (\text{Chi square value for MTTF upper limit})$$

└ Thermal acceleration factor assuming a 0.8eV activation energy

$$\lambda = 1.94 \times 10^{-9} \quad \lambda = 1.94 \text{ F.I.T. (60\% confidence level @ 25°C)}$$

This low failure rate represents data collected from Maxim's reliability qualification and monitor programs. Maxim also performs weekly Burn-In on samples from production to assure the reliability of its processes. The reliability required for lots which receive a burn-in qualification is 59 F.I.T. at a 60% confidence level, which equates to 3 failures in an 80 piece sample. Maxim performs failure analysis on lots exceeding this level. The following Burn-In Schematic (Spec. # 06-5189) shows the static circuit used for this test. Maxim also performs 1000 hour life test monitors quarterly for each process. This data is published in the Product Reliability Report (**RR-1M**).

B. Moisture Resistance Tests

Maxim evaluates pressure pot stress from every assembly process during qualification of each new design. Pressure Pot testing must pass a 20% LTPD for acceptance. Additionally, industry standard 85°C/85%RH or HAST tests are performed quarterly per device/package family.

C. E.S.D. and Latch-Up Testing

The RS86-9 die type has been found to have all pins able to withstand a transient pulse of $\pm 3000\text{V}$, per Mil-Std-883 Method 3015 (reference attached ESD Test Circuit). Latch-Up testing has shown that this device withstands a current of $\pm 250\text{mA}$.

Table 1
Reliability Evaluation Test Results

MAX3089xxD

TEST ITEM	TEST CONDITION	FAILURE IDENTIFICATION	PACKAGE	SAMPLE SIZE	NUMBER OF FAILURES
Static Life Test (Note 1)					
	Ta = 135°C Biased Time = 192 hrs.	DC Parameters & functionality		560	0
Moisture Testing (Note 2)					
Pressure Pot	Ta = 121°C P = 15 psi. RH= 100% Time = 168hrs.	DC Parameters & functionality	SO	77	0
			PDIP	77	0
85/85	Ta = 85°C RH = 85% Biased Time = 1000hrs.	DC Parameters & functionality		77	0
Mechanical Stress (Note 2)					
Temperature Cycle	-65°C/150°C 1000 Cycles Method 1010	DC Parameters & functionality		77	0

Note 1: Life Test Data may represent plastic DIP qualification lots.

Note 2: Generic Package/Process data

Attachment #1

TABLE II. Pin combination to be tested. ^{1/} ^{2/}

	Terminal A (Each pin individually connected to terminal A with the other floating)	Terminal B (The common combination of all like-named pins connected to terminal B)
1.	All pins except V_{PS1} ^{3/}	All V_{PS1} pins
2.	All input and output pins	All other input-output pins

^{1/} Table II is restated in narrative form in 3.4 below.

^{2/} No connects are not to be tested.

^{3/} Repeat pin combination I for each named Power supply and for ground

(e.g., where V_{PS1} is V_{DD} , V_{CC} , V_{SS} , V_{BB} , GND, $+V_S$, $-V_S$, V_{REF} , etc).

3.4 Pin combinations to be tested.

- a. Each pin individually connected to terminal A with respect to the device ground pin(s) connected to terminal B. All pins except the one being tested and the ground pin(s) shall be open.
- b. Each pin individually connected to terminal A with respect to each different set of a combination of all named power supply pins (e.g., V_{SS1} , or V_{SS2} or V_{SS3} or V_{CC1} , or V_{CC2}) connected to terminal B. All pins except the one being tested and the power supply pin or set of pins shall be open.
- c. Each input and each output individually connected to terminal A with respect to a combination of all the other input and output pins connected to terminal B. All pins except the input or output pin being tested and the combination of all the other input and output pins shall be open.

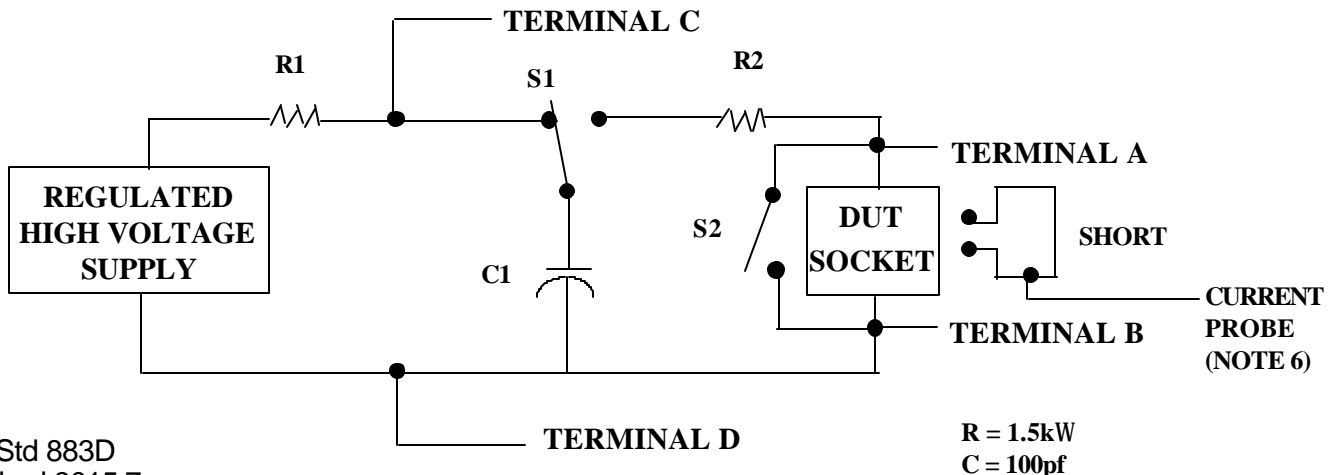

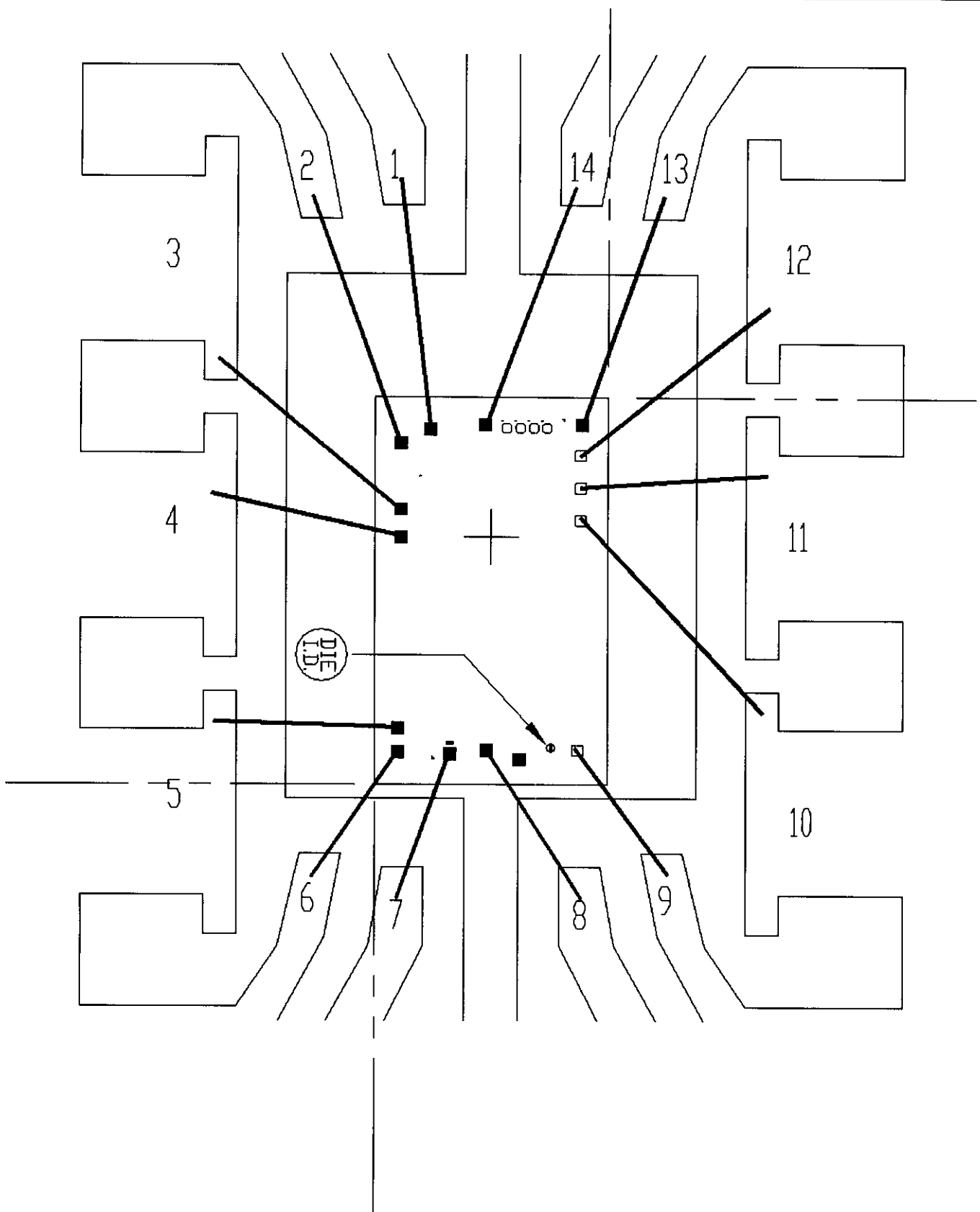

PKG.CODE: P14-4

APPROVALS

DATE

MAXIM

CAV./PAD SIZE:
150 X 190

PKG.
DESIGN

BUILDSHEET NUMBER:
05-1901-0153

REV.:
A

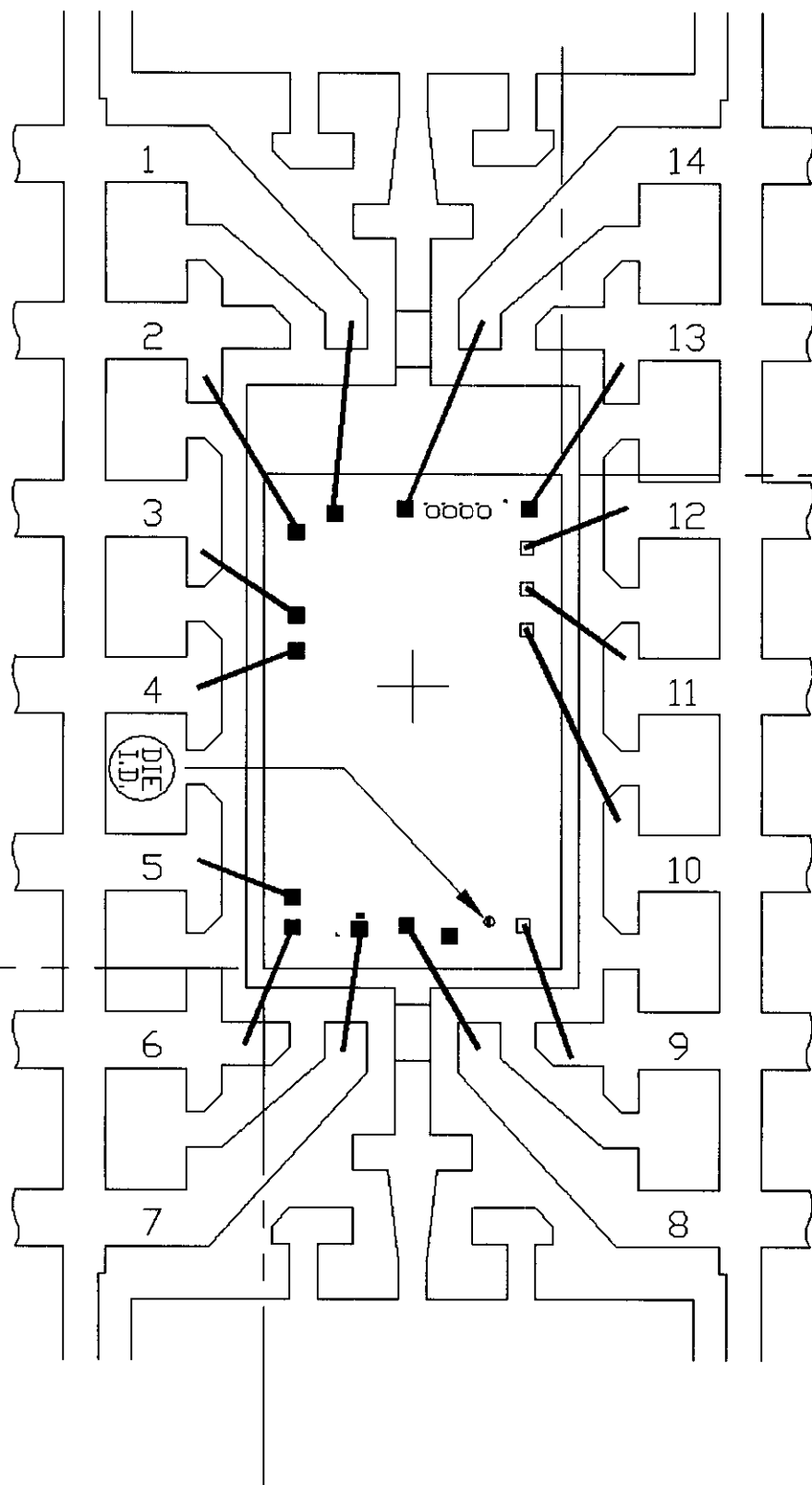

PKG.CODE: S14-4

APPROVALS

DATE

MAXIM

CAV./PAD SIZE:
95X170

PKG.
DESIGN

BUILDSHEET NUMBER:
05-1901-0154

REV.:
A

ONCE PER SOCKET

ONCE PER BOARD

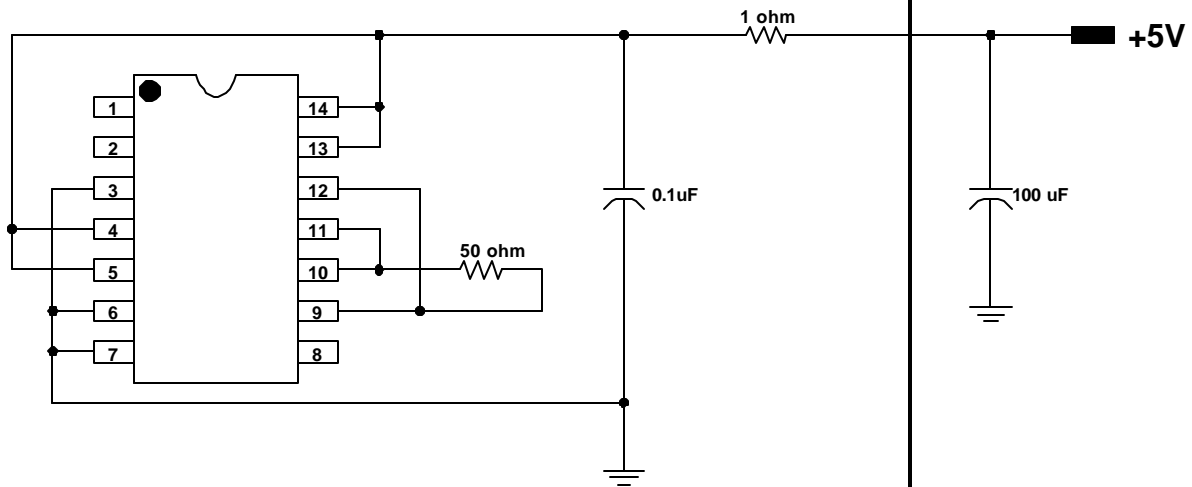

DEVICES: MAX489/491/3080/3083/3086
PACKAGE: 14 - NSO
MAX. EXPECTED CURRENT= 50mA

DRAWN BY: HAK TAN
NOTES: