

## MAX33048E Shield Evaluation Kit

Evaluates: **MAX33048E**

### General Description

The MAX33048E Shield evaluation kit (EV kit) is a fully assembled and tested printed circuit board (PCB) that demonstrates the functionality of the MAX33048E, a 20Mbps full-duplex RS-485 transceiver with  $\pm 25V$  fault protection, extended -7V to +12V common-mode range, and  $\pm 40kV$  ESD Human Body Model (HBM) for A/B and Y/Z data lines. The shield features a digital isolator which is used as a level translator between the RS-485 transceiver and the controller interface.

### Features

- Easy Evaluation of the MAX33048E
- I/O Interface Compatibility from 1.71V to 5.5V
- Proven PCB Layout
- Arduino®/Arm® Mbed™ Platform Compatible
- Fully Assembled and Tested

[Ordering Information](#) appears at end of data sheet.

### Quick Start

#### Required Equipment

- MAX33048E Shield
- 3.3V or 5V, 500mA DC power supply
- Signal/function generator that can generate a 10MHz square wave signal
- Oscilloscope

#### Procedure

1. Place the MAX33048E Shield EV kit on a nonconductive surface to ensure that nothing on the PCB gets shorted to the workspace.
2. Verify that all jumpers are in their default position as shown in [Table 1](#) and [Table 2](#).
3. With +3.3V power supply disabled, connect the positive terminal to VCC\_EXT test point and IOREF test point. Connect the negative terminal to the GND test points (TP18 or TP20).
4. Set the function generator to output a 10MHz square wave between 0V to 3.3V.
5. Connect the positive terminal of the function generator to pin DI and negative terminal to any GND test point on the shield board.
6. Connect Driver output Y to Receiver input A and Z to B.
7. Turn on the +3.3V DC Power Supply, and then enable function generator output.

Connect oscilloscope probes on RO and verify that both signals are 10MHz, 3.3V square waves.

### EV Kit Photo

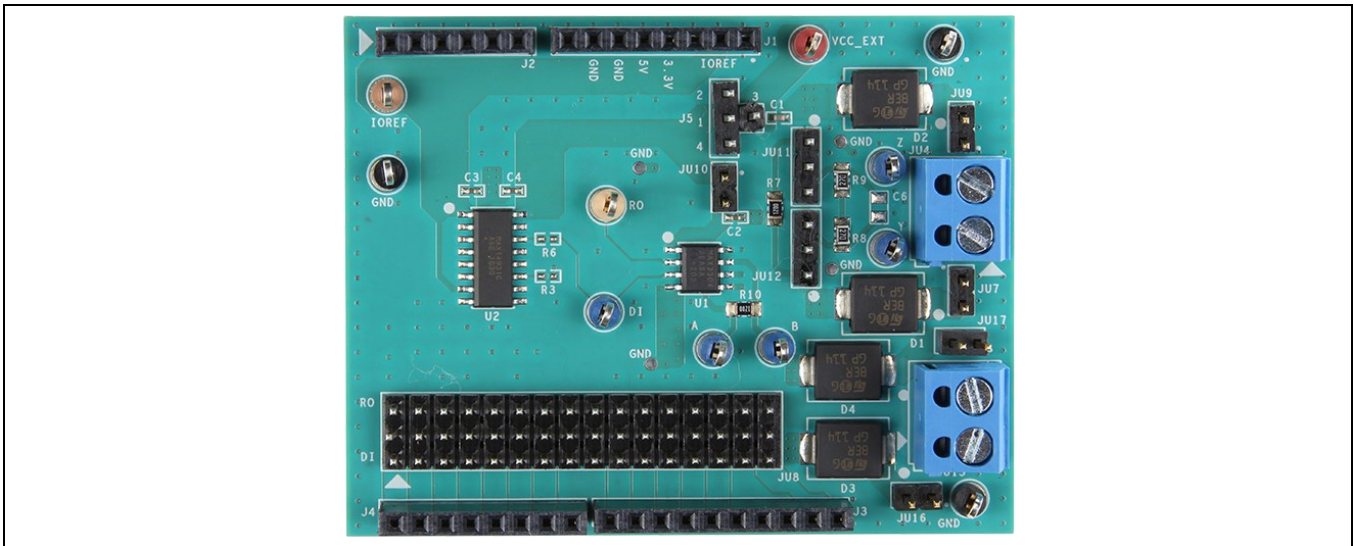

Table 1. Jumper Settings

JUMPER	SHUNT POSITION	DESCRIPTION
JU7	1-2	TVS Diode (DNI) connected to port Y
	Open*	TVS Diode (DNI) disconnected from port Y
JU9	1-2	TVS Diode (DNI) connected to port Z
	Open*	TVS Diode (DNI) disconnected from port Z
JU10	1-2*	Connects VCC pin of U1 to supply rail
	Open	Disconnects VCC pin of U1 from supply rail
JU11 and JU12	1-2*	Connects 120Ω between Y and Z
	2-3	Connects 54Ω between Y and Z
	Open	No load is connected between Y and Z
JU14	1	Driver output Y
	2	Driver output Z
JU15	1	Receiver input A
	2	Receiver input B
JU16	1-2	TVS Diode (DNI) connected to port A
	Open*	TVS Diode (DNI) disconnected from port A
JU17	1-2	TVS Diode (DNI) connected to port B
	Open*	TVS Diode (DNI) disconnected from port B
J5	1-2	VCC connects to onboard 3.3V
	1-3*	VCC connects to VCC_EXT
	1-4	VCC connects to onboard 5.0V
	Open	No supply to U1

\*Default jumper state.

Table 2. DI and RO Jumper Settings

JUMPER	SHUNT POSITION	DESCRIPTION
JU8	1-2	Connects DI to D0
	4-5	Connects DI to D1
	7-8	Connects DI to D2
	10-11	Connects DI to D3
	13-14	Connects DI to D4
	16-17	Connects DI to D5
	19-20	Connects DI to D6
	22-23	Connects DI to D7
	25-26	Connects DI to D8
	28-29	Connects DI to D9
	31-32	Connects DI to D10
	34-35	Connects DI to D11
	37-38	Connects DI to D12
	40-41	Connects DI to D13
	43-44	Connects DI to D14
	46-47	Connects DI to D15
	2-3	Connects RO to D0
	5-6	Connects RO to D1
	8-9	Connects RO to D2
	11-12	Connects RO to D3
	14-15	Connects RO to D4
	17-18	Connects RO to D5
	20-21	Connects RO to D6
	23-24	Connects RO to D7
	26-27	Connects RO to D8
	29-30	Connects RO to D9
	32-33	Connects RO to D10
	35-36	Connects RO to D11
	38-39	Connects RO to D12
	41-42	Connects RO to D13
	44-45	Connects RO to D14
	47-48	Connects RO to D15

## Detailed Description of Hardware

The MAX33048E Shield EV kit is a fully assembled and tested circuit board for evaluating the MAX33048E, a fault-protected full-duplex RS-485 transceiver (U1) with  $\pm 25V$  of fault protection. The Shield EV kit is designed to evaluate the MAX33048E alone or in a RS-485 system. The MAX33048E Shield EV kit can also enable the Arduino or Mbed platform to communicate on a RS-485 bus. The MAX14931 digital isolator is used as a level translator with a 1.71V to 5.5V supply range. Remove the  $0\Omega$  resistor R6 (default) to apply the transmitter input signal directly on the DI test point. Likewise, remove the  $0\Omega$  resistor R3 (default) to measure the receiver output signal directly on the RO test point.

The shield also features an option for TVS diodes (D1/D2 and D3/D4) that can be connected to the Y/Z and A/B lines using JU16/JU17 and JU7/JU9 respectively if external protection is desired beyond the device's built-in protection.

### Powering the Board

The MAX33048E Shield EV kit requires two power supplies: one 3V to 5.5V supply for the MAX33048E (U1) transceiver applied at the VCC\_EXT test point and one 1.71V to 5.5V supply for the microcontroller domain applied at the IOREF test point. When the shield EV kit board is used with an Arduino/Mbed platform, the power supply for U1 can also come from the Arduino/Mbed platform's 3.3V or 5V rail. Place the shunt on 1-3 position of J5 to connect V<sub>CC</sub> to VCC\_EXT pin. Place the shunt of J5 on the 1-2 position or the 1-4 position to connect the V<sub>CC</sub> of U1 to the Arduino/Mbed platform's 3.3V or 5V supply rail. In this scenario, IOREF is directly taken from the Arduino/Mbed platform header.

### On-Board Termination

A properly terminated RS-485 bus is terminated at each end with the characteristic impedance of the cable. For CAT5 or CAT6 cables, this is typically 120 $\Omega$  on each end for a 54 $\Omega$  load on the RS-485 driver. The MAX33048E Shield EV kit features a selectable 54 $\Omega$  or 120 $\Omega$  load circuit between the Y and Z driver outputs and fixed 120 $\Omega$  between A and B receiver inputs. If the board is evaluated in a system and connected at the end of the cable, select 120 $\Omega$  termination. The termination resistors on the MAX33048E Shield EV kit should be changed to 54 $\Omega$  with a 100pF load to simulate a complete system load during evaluation.

### DI and RO Configuration

Digital channels for DI and RO are selected through JU8, which consists of three columns and 16 rows. The columns labeled DI and RO are connected to MAX33048E through the digital isolator (MAX14931FASE+ (U2)). The middle column contains the digital I/O pins D0 to D15 from the Arduino/Mbed platform header. This provides flexibility for the user to select different resources on the microcontroller to transmit and receive signals to and from the RS-485 transceiver. [Table 2](#) shows the list of JU8 jumper options. For single-channel performance verification, driver input can connect to test point DI and probe to test point RO directly.

### Flexible Interface Options

The MAX33048E Shield EV kit allows multiple points of connection to the MAX33048E transceiver. The shield EV kit board can be placed on an Arduino/Mbed platform header to connect all the digital pins (DI and RO) through the J3 and J4 headers. These signals can also be connected directly at their respective test points on the board, bypassing the digital isolator (U2). The Y/Z signals are connected to a terminal block (JU4) and A/B signals to JU15 to easily connect to twisted pair cables. Alternately, the Y/Z and A/B test points can be used.

### PCB Layout for Thermal Dissipation

PCB layout can affect the performance of the transceiver in conditions with a high common-mode voltage at high ambient temperatures. The layout of the MAX33048E Shield EV kit is designed to maximize thermal performance in such cases. The GND pad is connected to a large copper plane on the top layer, with vias throughout the plane connecting to the GND plane on the bottom layer. A thick trace from the V<sub>CC</sub> pad to JU10 allows for greater heat dissipation at the V<sub>CC</sub> pin.

## Ordering Information

PART	TYPE
MAX33048ESHLD#	EV Kit

#Denotes RoHS-compliant.

## MAX33048E Shield EV Kit Bill of Materials

ITEM	QTY	REF DES	MFG PART #	MANUFACTURER	VALUE	DESCRIPTION
1	5	A, B, DI, Y, Z	5127	KEYSTONE	N/A	TEST POINT; BLUE; PHOSPHOR BRONZE WIRE SILVER PLATE FINISH;
2	1	C1	GRM155R60J106M E44	MURATA	10UF	CAP; SMT (0402); 10UF; 20%; 6.3V; X5R; CERAMIC
3	3	C2-C4	C0402C104J4RAC	KEMET;MURATA	0.1UF	CAP; SMT (0402); 0.1UF; 5%; 16V; X7R; CERAMIC
4	1	C6	08051A500FAT2A	AVX	50PF	CAP; SMT (0805); 50PF; 1%; 100V; C0G; CERAMIC
5	4	D1-D4	SM15T30CA	ST MICROELECTRONICS	25.6V	DIODE; TVS; SMC (DO- 214AB); VRM=25.6V; IPP=36A
6	1	IOREF	5125	KEYSTONE	N/A	TEST POINT; ; BROWN; NOT FOR COLD TEST
7	2	J1, J4	SSQ-108-24-G-S	SAMTEC	SSQ-108-24-G-S	CONNECTOR; FEMALE; THROUGH HOLE;
8	1	J2	SSQ-106-24-G-S	SAMTEC	SSQ-106-24-G-S	CONNECTOR; FEMALE; THROUGH HOLE;
9	1	J3	SSQ-110-24-G-S	SAMTEC	SSQ-110-24-G-S	CONNECTOR; FEMALE; THROUGH HOLE
10	1	J5	PEC04SAAN	SULLINS ELECTRONICS CORP.	PEC04SAAN	CONNECTOR; MALE; THROUGH HOLE; BREAKAWAY; STRAIGHT; 4PINS
11	2	JU4, JU15	OSTTA024163	ON-SHORE TECHNOLOGY INC.	OSTTA024163	CONNECTOR; FEMALE; THROUGH HOLE;
12	5	JU7, JU9, JU10, JU16, JU17	PCC02SAAN	SULLINS	PCC02SAAN	CONNECTOR; MALE; THROUGH HOLE;
13	1	JU8	TSW-116-07-T-T	SAMTEC	TSW-116-07-T-T	CONNECTOR; MALE; THROUGH HOLE; 0.025IN SQ POST HEADER; STRAIGHT; 48PINS
14	2	JU11, JU12	PEC03SAAN	SULLINS	PEC03SAAN	CONNECTOR; MALE; THROUGH HOLE
15	2	R7, R10	CRCW0805120RFK	VISHAY DALE	120	RES; SMT (0805); 120; 1%; +/-100PPM/DEGC; 0.1250W
16	2	R8, R9	ERA-6AHD270	PANASONIC	27	RES; SMT (0805); 27; 0.50%; +/-50PPM/DEGC; 0.1250W
17	1	RO	5012	KEYSTONE	N/A	TEST POINT; PIN DIA=0.125IN;
18	8	SU1, SU2, SU5, SU8- SU12	2SN-BK-G	SAMTEC	2SN-BK-G	TEST POINT; JUMPER; STR

19	3	TP18-TP20	5011	KEYSTONE	N/A	TEST POINT; PIN DIA=0.125IN;
20	1	U1	MAX33048EASA+	MAXIM	MAX33048EASA+	EVKIT PART - IC; MAX33048EASA+
21	1	U2	MAX14931CASE+	MAXIM	MAX14931CASE+	IC; DISO; 3/1 CHANNEL
22	1	VCC_EXT	5010	KEYSTONE	N/A	TEST POINT; PIN DIA=0.125IN;
23	1	PCB	MAX33048ESHIELD	MAXIM	PCB	PCB:MAX33048ESHIELD
24	2	R3, R6	ERJ-2GE0R00	PANASONIC	NL	RES; SMT (0402); 0; JUMPER; JUMPER; 0.1000W

MAX33048E Shield EV Kit Schematic

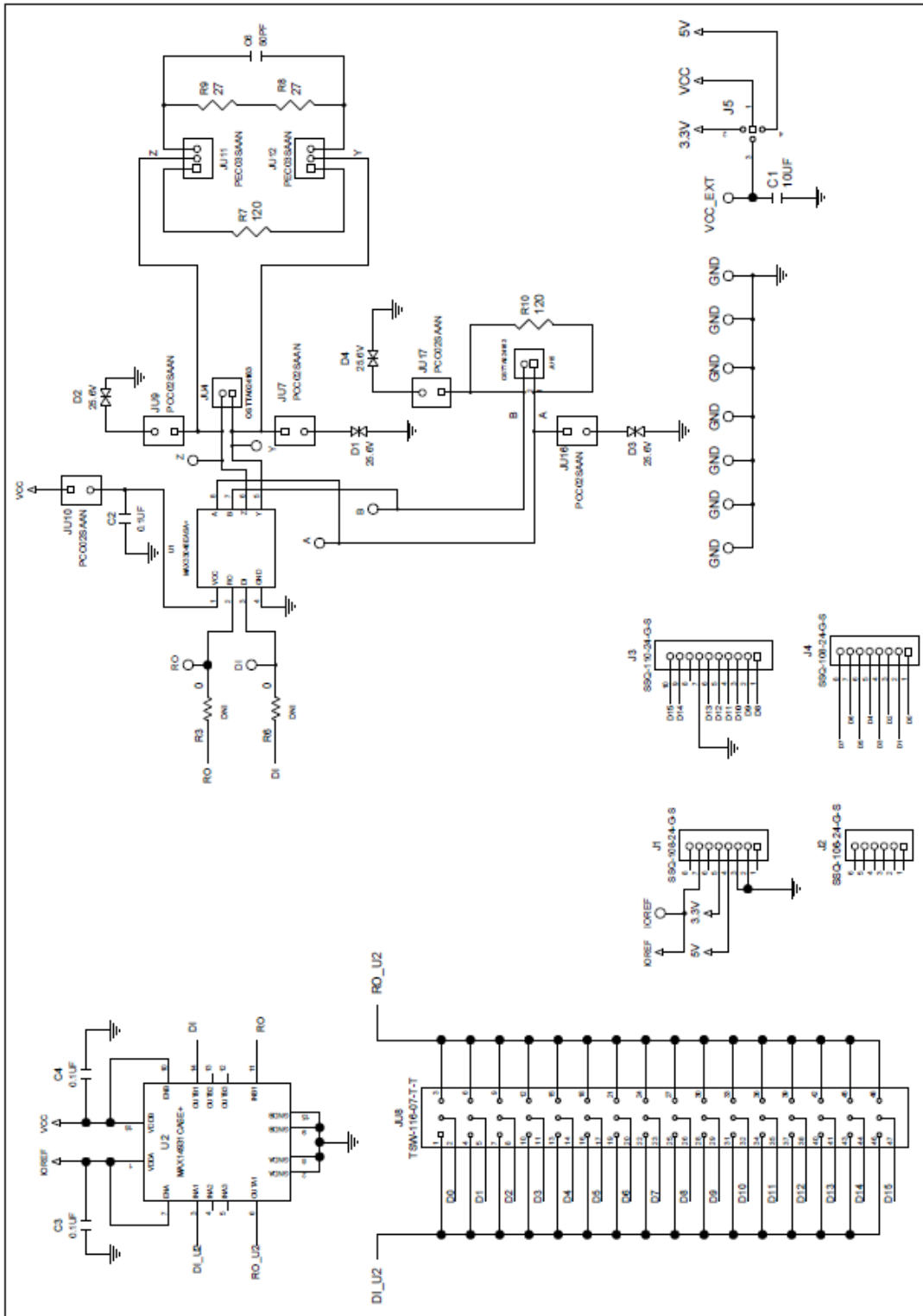

MAX33048E Shield EV Kit PCB Layout

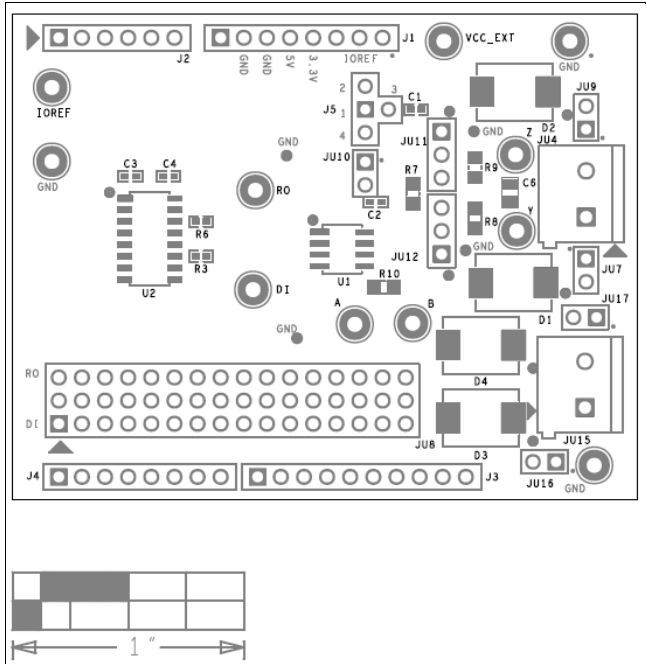

MAX33048E Shield EV Kit PCB Layout—Top Silkscreen

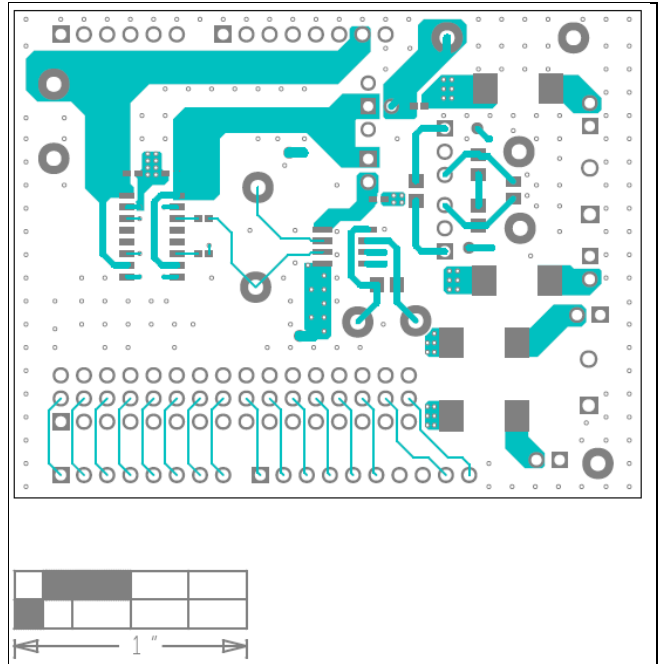

MAX33048E Shield EV Kit PCB Layout—Top Layer

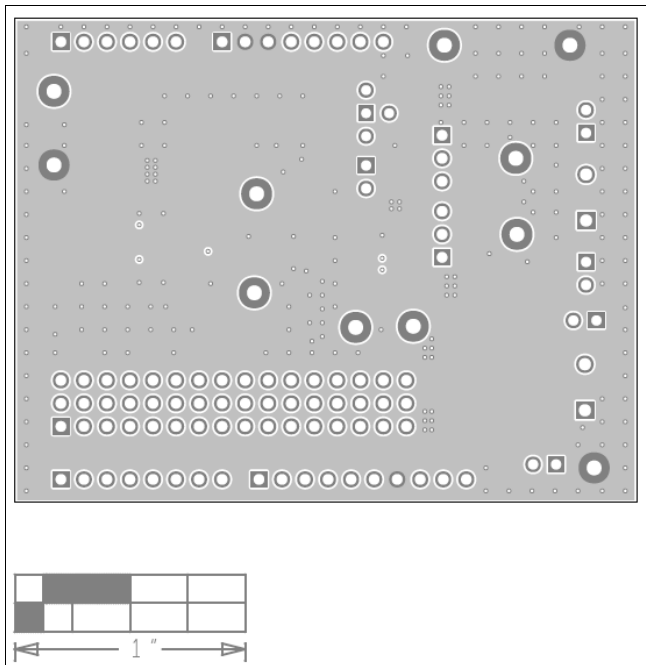

MAX33048E Shield EV Kit PCB Layout—Second Layer

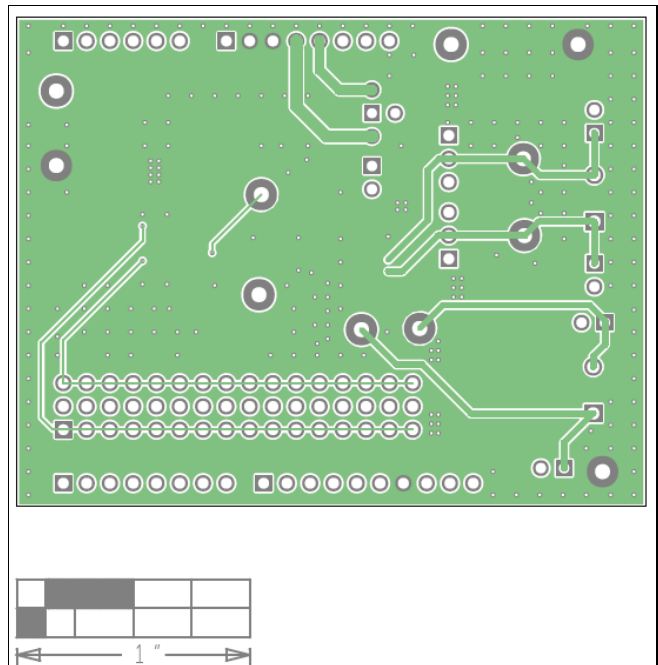

MAX33048E Shield EV Kit PCB Layout—Third Layer



MAX33048E Shield EV Kit PCB Layout (continued)

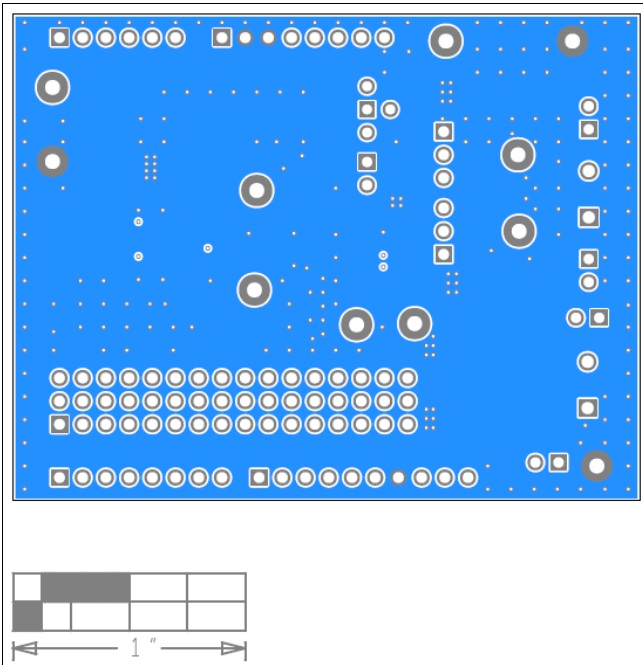

MAX33048E Shield EV Kit PCB Layout—Bottom Layer

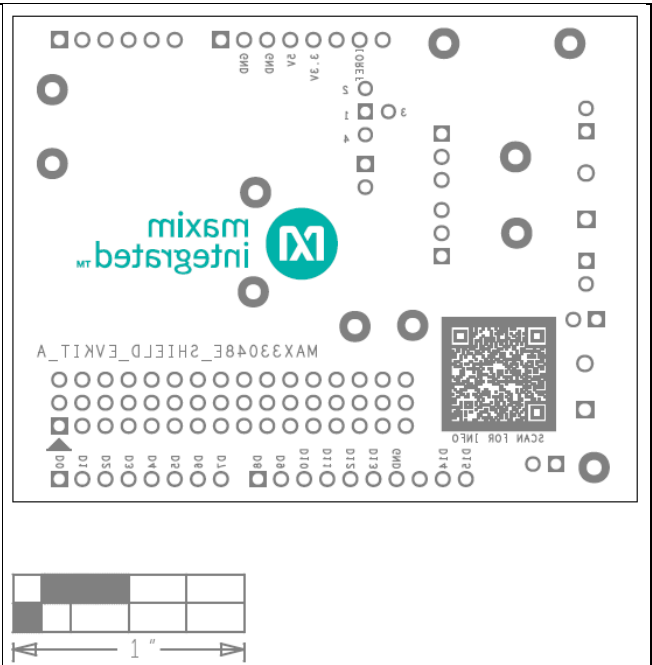

MAX33048E Shield EV Kit PCB Layout—Bottom Silkscreen

Revision History

REVISION NUMBER	REVISION DATE	DESCRIPTION	PAGES CHANGED
0	7/22	Initial release	—

Arduino® is a trademark of Arduino SA

Arm and Mbed are registered trademarks or trademarks of Arm Limited (or its subsidiaries) in the US and/or elsewhere.

