High Efficiency $\pm 2A$ Programmable Device Power Supply with 16-Bit Settings

FEATURES

- ▶ Programmable FV, FI, MI, MV, FNMV Functions
- ▶ Integrated Current-Sense Resistors with Measurement Ranges of $\pm 5\mu A$ up to $\pm 2A$
- ▶ Efficient Switching Supply Driver
 - ▶ Integrated Power Switches
 - ▶ Silent Switcher[®] Architecture
- ▶ 30V FV Span with up to $\pm 2A$ Drive
- ▶ Integrated Digital PID FV and FI Control Loops
- ▶ Gangable for Higher Current
- ▶ Kelvin Voltage Senses and Alarms
- ▶ Current and Voltage Clamping
- ▶ SPI or 2-Wire Serial Interface
- ▶ Supports Augmented Output Current
- ▶ 10mm x 12.75mm 166-Ball BGA

APPLICATIONS

- ▶ Automatic Test Equipment (ATE)
- ▶ Device Power Supply

GENERAL DESCRIPTION

The LT8740 is a two-channel programmable device power supply (DPS) with very high efficiency, integration, and performance. The part consists of two switching power supplies providing up to $\pm 2A$ of current each at output voltages spanning 30V. Current sensing resistors are integrated, supporting accurate output current measurement in ranges spanning $\pm 5\mu A$ up to $\pm 2A$. A linear drive stage is also included, allowing no-switching ripple output drive of up to $\pm 25mA$. Output currents in excess of $\pm 2A$ can be achieved by paralleling or ganging multiple DPS channels and/or devices.

The LT8740 also includes the required ADCs and DACs to set the programmable output, regulated under digital PID control, and clamp the output current and voltage. Output voltage and current can be measured digitally using the internal ADCs.

Open-drain alarm outputs are provided for overcurrent, overtemperature, or other programmable fault events. The DPS functions are controlled through a simple serial interface running at clock speeds of up to 40 MHz.

High Efficiency $\pm 2A$ Programmable Device Power Supply with 16-Bit Settings

TYPICAL APPLICATION

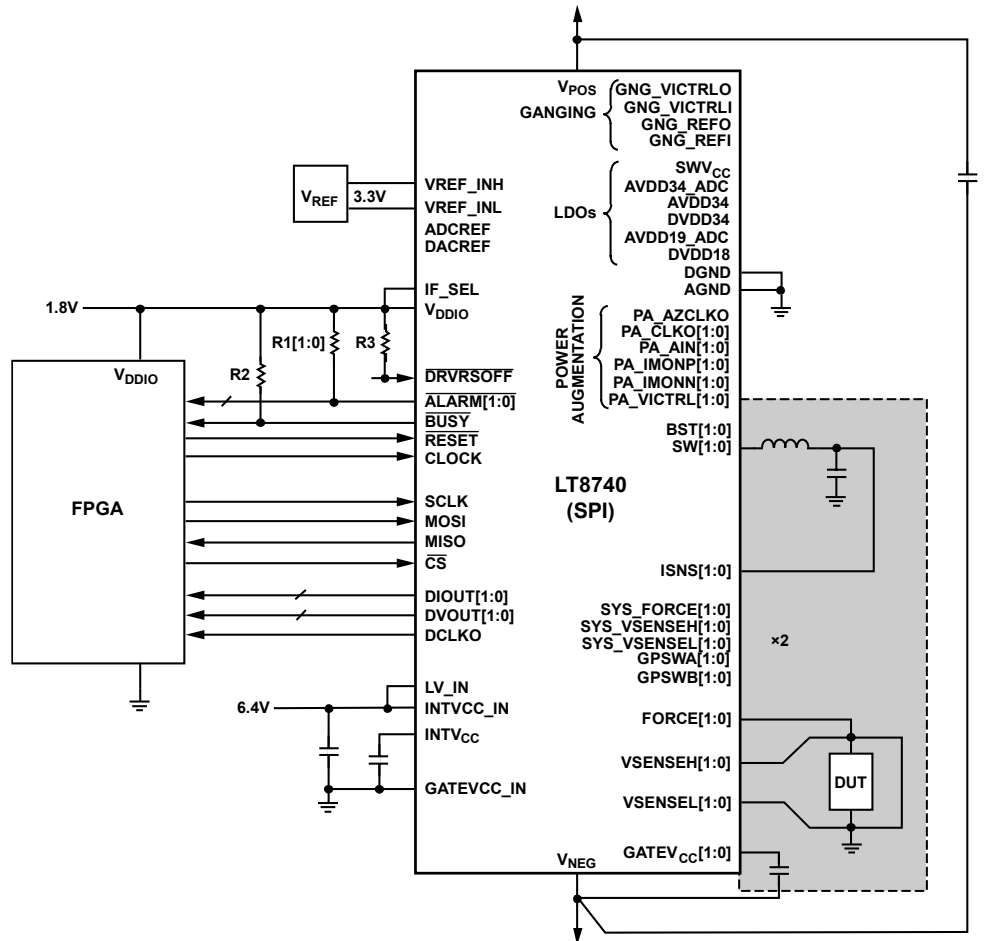

Figure 1. Simplified Dual Channel $\pm 2A$, 30V Span DPS Schematic for ATE Applications (SPI)

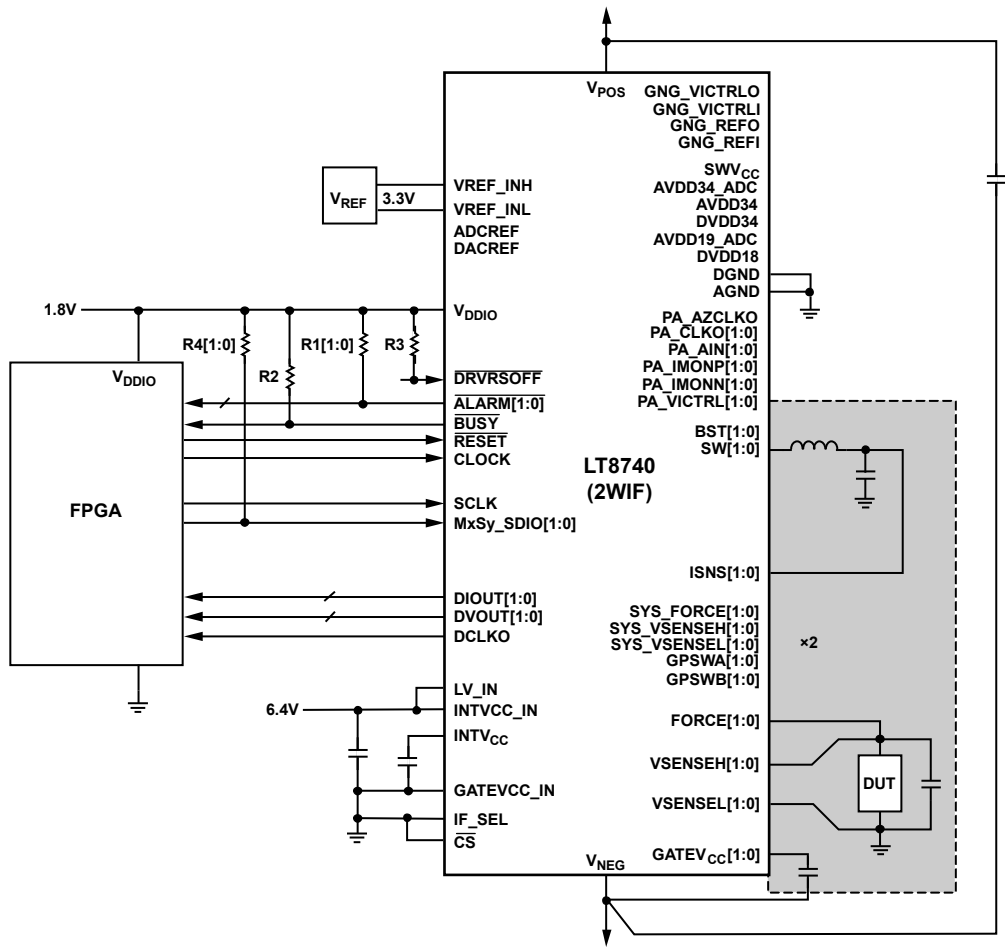

Figure 2. Simplified Dual Channel $\pm 2A$, 30V Span DPS Schematic for ATE Applications (2WIF)

ALL INFORMATION CONTAINED HEREIN IS PROVIDED "AS IS" WITHOUT REPRESENTATION OR WARRANTY. NO RESPONSIBILITY IS ASSUMED BY ANALOG DEVICES FOR ITS USE, NOR FOR ANY INFRINGEMENTS OF PATENTS OR OTHER RIGHTS OF THIRD PARTIES THAT MAY RESULT FROM ITS USE. SPECIFICATIONS ARE SUBJECT TO CHANGE WITHOUT NOTICE. NO LICENCE, EITHER EXPRESSED OR IMPLIED, IS GRANTED UNDER ANY ADI PATENT RIGHT, COPYRIGHT, MASK WORK RIGHT, OR ANY OTHER ADI INTELLECTUAL PROPERTY RIGHT RELATING TO ANY COMBINATION, MACHINE, OR PROCESS, IN WHICH ADI PRODUCTS OR SERVICES ARE USED. TRADEMARKS AND REGISTERED TRADEMARKS ARE THE PROPERTY OF THEIR RESPECTIVE OWNERS. ALL ANALOG DEVICES PRODUCTS CONTAINED HEREIN ARE SUBJECT TO RELEASE AND AVAILABILITY.