

4V to 20V, 100mA, Ultra-Low Quiescent Current, Linear Regulator

GENERAL DESCRIPTION

The ADPL42001 ultra-low quiescent current, high-voltage linear regulator is ideal for use in industrial and battery-operated systems. The device operates from a 4V to 20V input voltage, delivers up to 100mA of load current, and consumes only 8 μ A of quiescent current at no load. The device consumes only 0.9 μ A current when in shutdown. Output voltage is adjustable in the 0.6V to 18V voltage range. Feedback voltage accuracy is $\pm 2\%$ over temperature.

An open-drain PGOOD pin provides a power-good signal to the system, achieving successful regulation of the output voltage. The device also incorporates an enable pin (EN) that allows the user to turn the part on or off. The device has a thermal shutdown feature that shuts down the part when the die temperature exceeds 165°C. The ADPL42001 operates over the -40°C to +125°C industrial temperature range and is available in a 6-lead, compact TSOT and a 6-pin (3mm x 3mm) TDFN packages.

APPLICATIONS

- ▶ Battery-Powered Equipment
- ▶ Post Regulator for Switching Power Supplies
- ▶ Body Electronics and Lighting

BENEFITS AND FEATURES

- ▶ Easy to Use
 - ▶ Only 4 External Components Required
 - ▶ Stable with Tiny 4.7 μ F, 0805 Output Capacitor
 - ▶ All Ceramic Capacitors, Compact Layout
- ▶ Reduces Number of Linear Regulators to Stock
 - ▶ Wide 4V to 20V Input Voltage Range
 - ▶ Adjustable 0.6V to 18V Output
 - ▶ Up to 100mA Load Current Capability
- ▶ Operates Reliably in Adverse Industrial Environments
 - ▶ Built-In Output Voltage Monitoring with PGOOD Pin
 - ▶ High-Voltage ENABLE Input
 - ▶ Low 8 μ A Quiescent Current
 - ▶ Low Dropout Voltage of 560mV at 100mA
 - ▶ Overload Protection
 - ▶ Overtemperature Protection
 - ▶ Wide -40°C to +125°C Ambient Operating Temperature Range/-40°C to +150°C Junction Temperature Range

Ordering Information appears at end of data sheet.

TYPICAL APPLICATION CIRCUIT

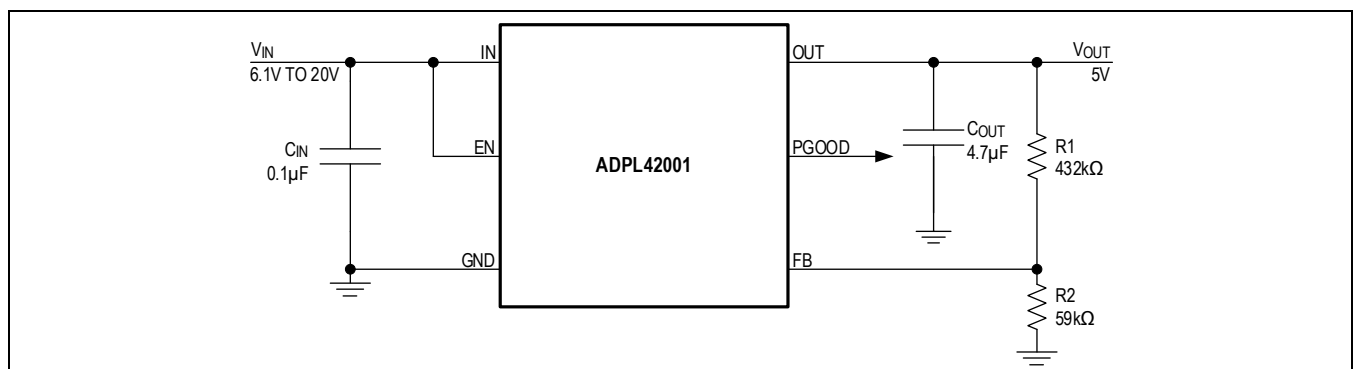

SPECIFICATIONS

Table 1. Electrical Characteristics

($V_{IN} = V_{EN} = 12V$, $V_{FB} = V_{OUT}$, PGOOD = OPEN, GND = 0V, $C_{OUT} = 4.7\mu F$, $T_A = -40^\circ C$ to $+125^\circ C$, unless otherwise noted. Typical values are at $T_A = +25^\circ C$. All voltages are referenced to GND, unless otherwise noted.) ⁽¹⁾

PARAMETER	SYMBOL	CONDITIONS	MIN	TYP	MAX	UNITS
INPUT SUPPLY (V_{IN})						
Input Voltage Range	V_{IN}		4		20	V
Input Supply Current	I_{IN-SH}	$V_{EN} = 0V$, shutdown mode		0.9	1.8	μA
	I_{IN-Q}	$V_{EN} = V_{IN}$, $I_{LOAD} = 0mA$		8	15	μA
ENABLE (EN)						
EN Threshold	V_{ENR}	V_{EN} rising	2			V
	V_{ENF}	V_{EN} falling			0.6	V
EN Leakage Current	I_{EN}	$T_A = +25^\circ C$	-100		+100	nA
FEEDBACK (FB)						
FB Regulation Voltage	V_{FB-REG}		0.588	0.6	0.612	V
FB Input Leakage Current	I_{FB}	$V_{FB} = 0.6V$, $T_A = 25^\circ C$	-25		+25	nA
CURRENT LIMIT						
Current Limit Threshold	I_{LIMIT}	$V_{IN} = 5.5V$, $V_{OUT} = 4.5V$	101	140	165	mA
PGOOD						
PGOOD Rising Threshold	$V_{PGOOD-RISE}$	V_{FB} rising	89.5	92	94.5	%
PGOOD Falling Threshold	$V_{PGOOD-FALL}$	V_{FB} falling	87	89.5	92	%
PGOOD Output Level Low		$I_{PGOOD} = 1mA$			0.2	V
PGOOD Output Leakage Current		$V_{PGOOD} = 5.5V$, $T_A = +25^\circ C$			1	μA
OUTPUT VOLTAGE						
Dropout Voltage	V_{DO}	$V_{IN} = 4.5V$, $I_{LOAD} = 50mA$		280	550	mV
Dropout Voltage	V_{DO}	$V_{IN} = 4.5V$, $I_{LOAD} = 100mA$		560	1100	mV
Line Regulation		$V_{IN} = 4V$ to $20V$, $V_{OUT} = FB$, $I_{LOAD} = 1mA$		0.1		%
Load Regulation		$0.1mA < I_{LOAD} < 100mA$, $V_{OUT} = FB$		0.5	1.2	%
THERMAL SHUTDOWN						
Thermal-Shutdown Threshold		Temperature rising		165		$^\circ C$
Thermal-Shutdown Hysteresis				15		$^\circ C$

¹ All electrical specifications are 100% production tested at $T_A = +25^\circ C$. Specifications over the operating temperature range are guaranteed by design and characterization.

ABSOLUTE MAXIMUM RATINGS

Table 2. Absolute Maximum Ratings

PARAMETER	RATING
IN to GND	-0.3V to +22V
EN, OUT to GND	-0.3V to IN + 0.3V
FB, PGOOD to GND	-0.3V to +6V
Output Short-Circuit Duration	Continuous
Operating Temperature Range ⁽¹⁾	-40°C to +125°C
Junction Temperature	+150°C
Storage Temperature Range	-65°C to +160°C
Lead Temperature (soldering 10s)	+300°C

¹ Junction temperature greater than +125°C degrades operating lifetimes.

Stresses beyond those listed under Absolute Maximum Ratings may cause permanent damage to the device. These are stress ratings only, functional operation of the product at these or any other conditions above those indicated in the operational section of this specification is not implied. Operation beyond the maximum operating conditions for extended periods may affect product reliability.

PIN CONFIGURATIONS AND FUNCTION DESCRIPTIONS

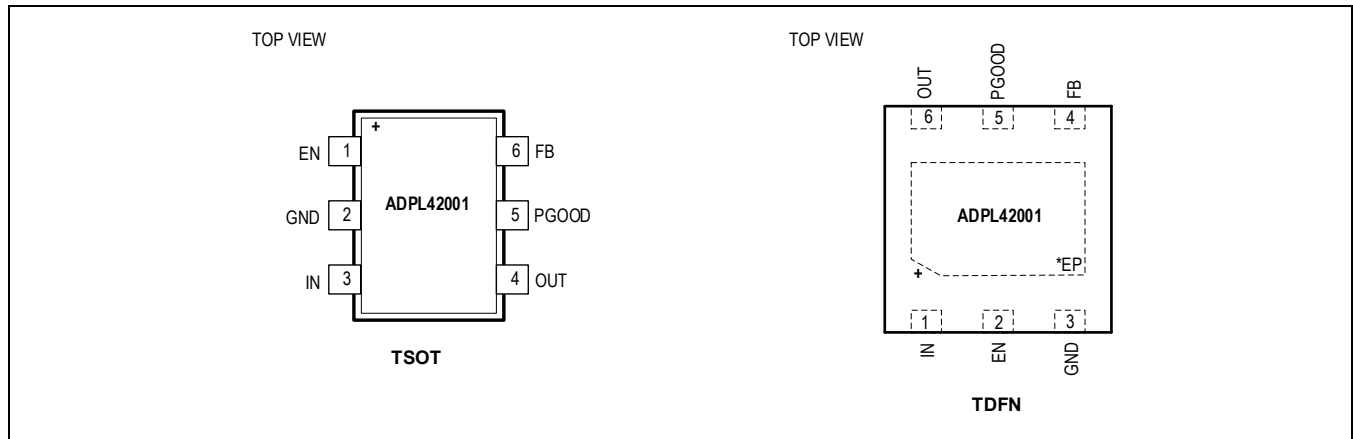

Pin Descriptions

Table 3. Pin Descriptions

PIN		NAME	DESCRIPTION
TSOT	TDFN		
1	2	EN	Active-High, Enable Input. Force EN high (or connect to IN) to turn the regulator on. Pull EN to GND to place the device in a low-power shutdown mode.
2	3	GND	Ground. Connect GND to the ground plane.
3	1	IN	Power-Supply Input. Decouple to GND with a 0.1 μ F capacitor; place the capacitor close to the IN and GND pins.
4	6	OUT	Regulator Output. Connect at least 4.7 μ F, 0805 capacitor from OUT to GND.
5	5	PGOOD	Open-Drain PGOOD Output. Pull up PGOOD to an external power supply. PGOOD pulls low if FB drops below 89% of its set value. PGOOD goes high after FB rises above 92% of its set value. The PGOOD pin can be left floating if not used.
6	4	FB	Output Feedback Connection. Connect FB to a resistor divider between V_{OUT} and GND to adjust the output voltage from 0.6V to 18V.
—	—	EP	Exposed Pad (TDFN Only). Always connect EP to the GND pin of the IC. Connect EP to a large GND plane with several thermal vias for best thermal performance. Refer to the ADPL42001ATT EV kit user guide for an example of the correct method for EP connection and thermal vias.

TYPICAL PERFORMANCE CHARACTERISTICS

($V_{IN} = V_{EN} = 7V$, $V_{OUT} = 5V$, $C_{OUT} = 4.7\mu F$ $T_A = +25^\circ C$, unless otherwise noted.)

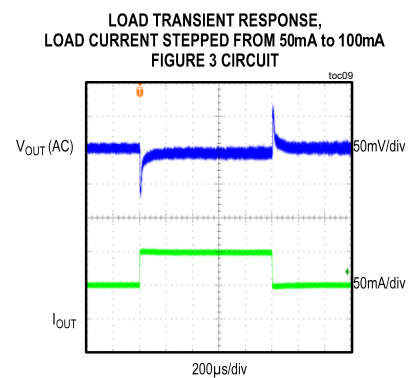
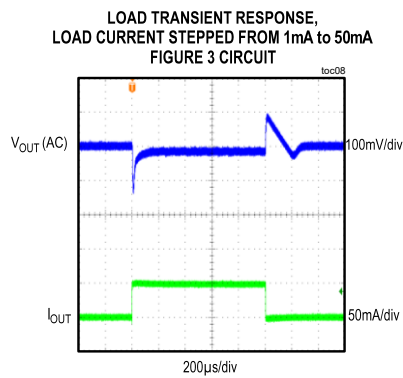
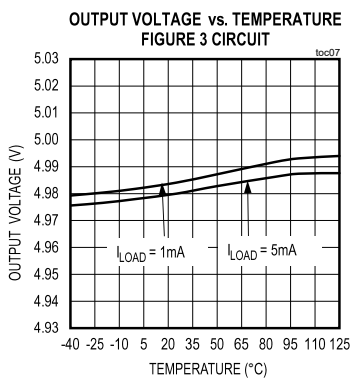
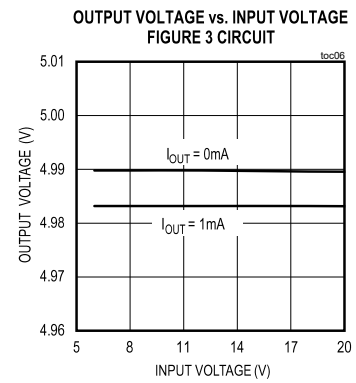
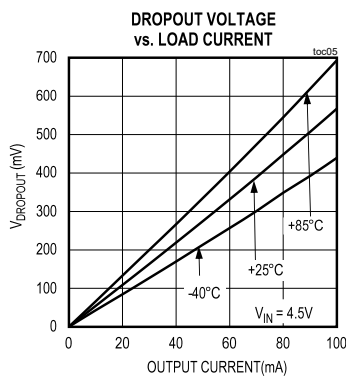
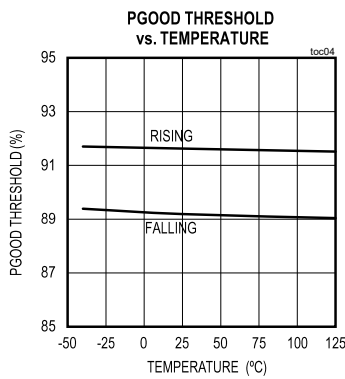
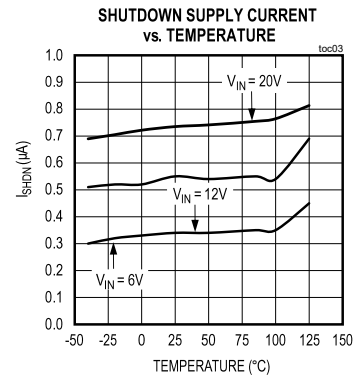
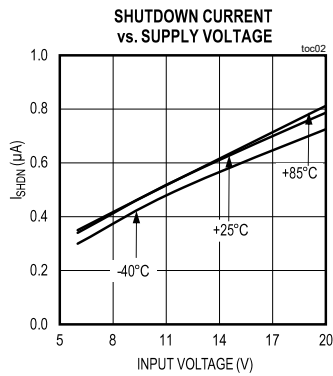
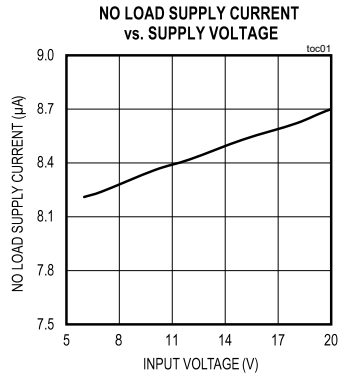

INPUT-VOLTAGE STEP RESPONSE
WITH 100mA LOAD CURRENT
FIGURE 3 CIRCUIT

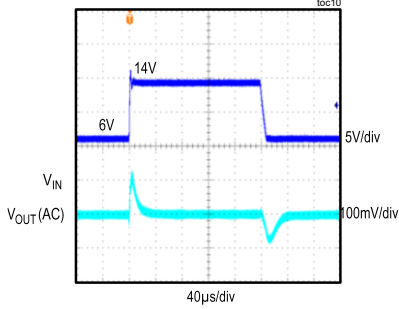

STARTUP RESPONSE
WITH NO LOAD
FIGURE 3 CIRCUIT

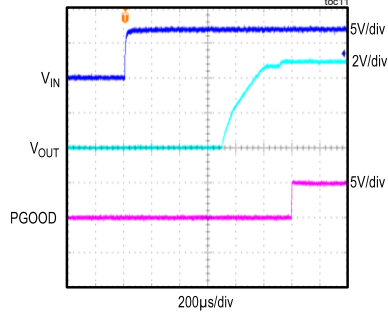

STARTUP RESPONSE
WITH 100mA LOAD
FIGURE 3 CIRCUIT

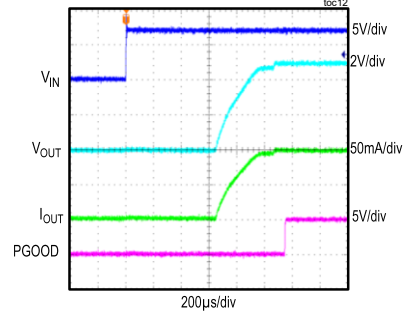

STARTUP RESPONSE
WITH ENABLE (NO LOAD)
FIGURE 3 CIRCUIT

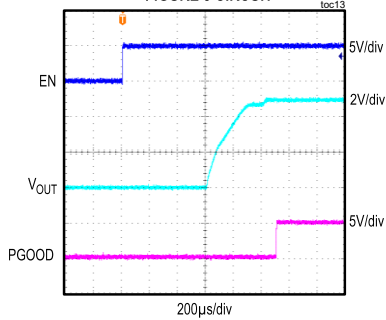

STARTUP RESPONSE
WITH ENABLE AND 100mA LOAD
FIGURE 3 CIRCUIT

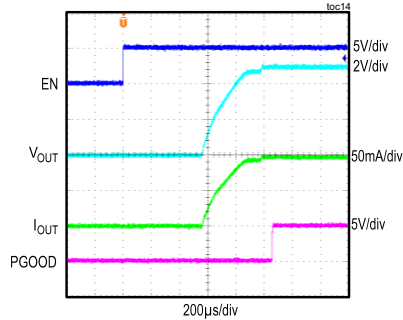

POWER SUPPLY REJECTION RATIO
FIGURE 3 CIRCUIT

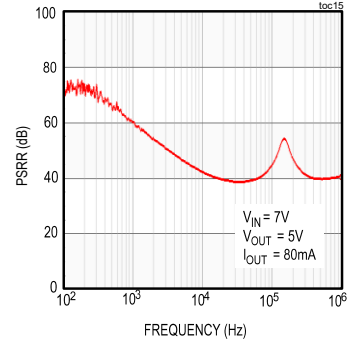

FUNCTIONAL DIAGRAM

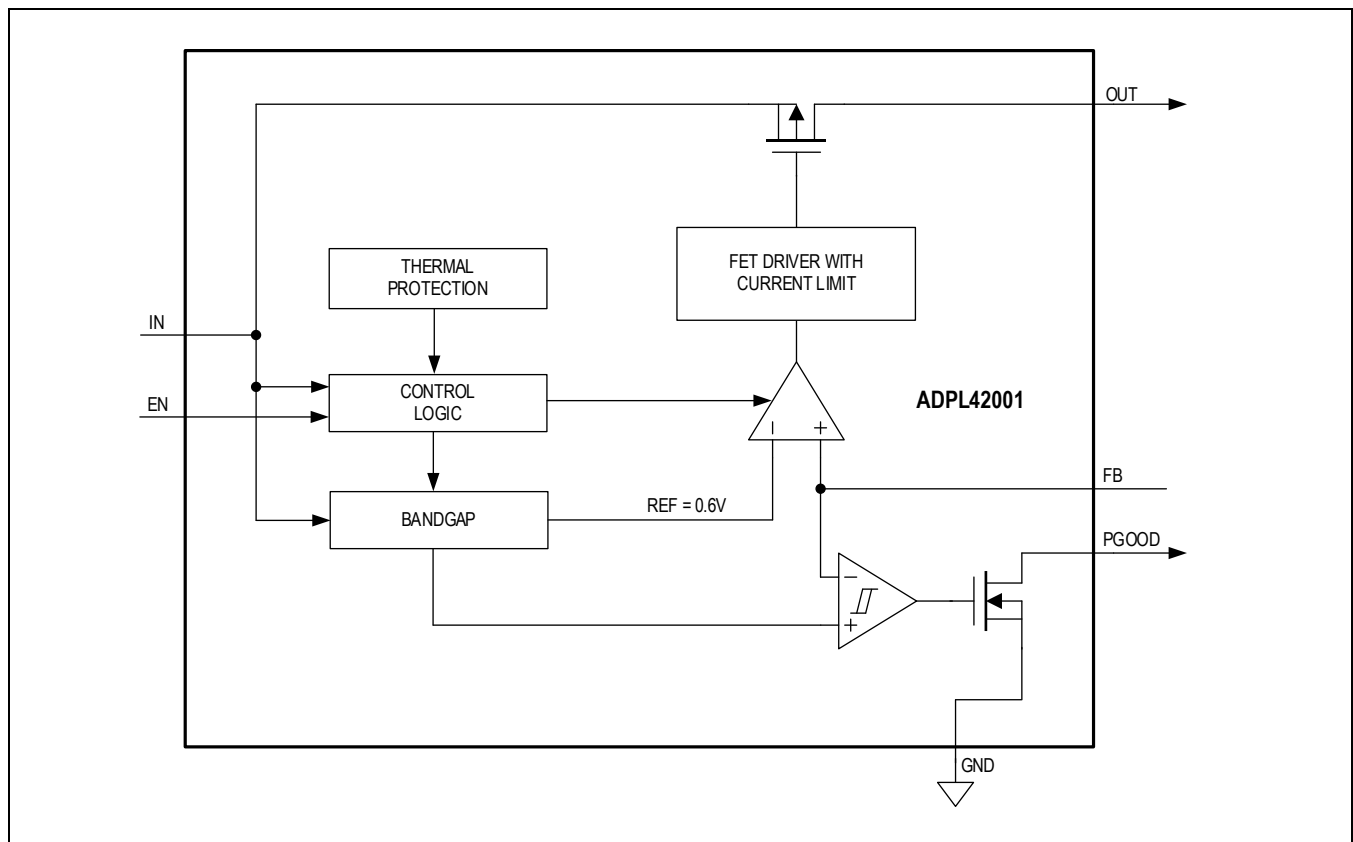

Figure 1. Block Diagram

THEORY OF OPERATION

The ADPL42001 ultra-low quiescent current, high-voltage linear regulator is ideal for use in industrial and battery-operated systems. The device operates from a 4V to 20V input voltage, delivers up to 100mA of load current and consumes only 8 μ A of quiescent current at no load. The device consumes only 0.9 μ A current when in shutdown. Output voltage is adjustable from 0.6V to 18V voltage range. Feedback voltage accuracy is $\pm 2\%$ over temperature.

An open-drain PGOOD pin provides a power-good signal to the system upon achieving successful regulation of the output voltage. The device also incorporates an enable pin (EN) that allows the user to turn the part on or off. The device has a thermal shutdown feature that shuts down the part when the die temperature exceeds 165°C. The ADPL42001 operates over the -40°C to +125°C industrial temperature range and is available in a compact, 6-lead TSOT and a 6-pin (3mm x 3mm) TDFN packages.

EN Input

EN is an active-high, logic-level enable input that turns the device on or off. Drive EN high to turn the device on. While in shutdown, the device consumes only 0.9 μ A (typ). EN withstands voltages up to $V_{IN} + 0.3V$, allowing it to be driven by high input-level voltages, or be connected to IN for always-on operation.

Thermal Protection

When the junction temperature exceeds +165°C, an internal thermal sensor turns the pass transistor off, allowing the device to cool. The thermal sensor turns the pass transistor on again after the junction temperature cools by 15°C. This results in a cycled output during continuous thermal-overload conditions. Thermal protection protects the ADPL42001 in the event of fault conditions.

Output Short-Circuit Current Limit

The ADPL42001 features a 140mA (typ) current limit. The output can be shorted to GND for an indefinite period without damage to the device. During a short-circuit event, the power dissipated across the internal pass transistor can quickly heat the device. When the die temperature reaches +165°C, the ADPL42001 shuts down and automatically restarts once the die temperature cools by 15°C.

APPLICATIONS INFORMATION

Output Voltage Setting

The output voltage can be programmed from 0.6V to 18V. Set the output voltage by connecting a resistor divider from output to FB to GND. Choose R2 = 59kΩ, then calculate R1 with the following equation:

$$R1 = 98.3 \times (V_{OUT} - 0.6)k\Omega$$

Output Capacitor Selection

If the output voltage is less than 1.8V, use a low-ESR 10μF(min) 0805 ceramic output capacitor for good load transient response. If the output voltage is greater than or equal to 1.8V, use a low-ESR 4.7μF(min) 0805 ceramic output capacitor.

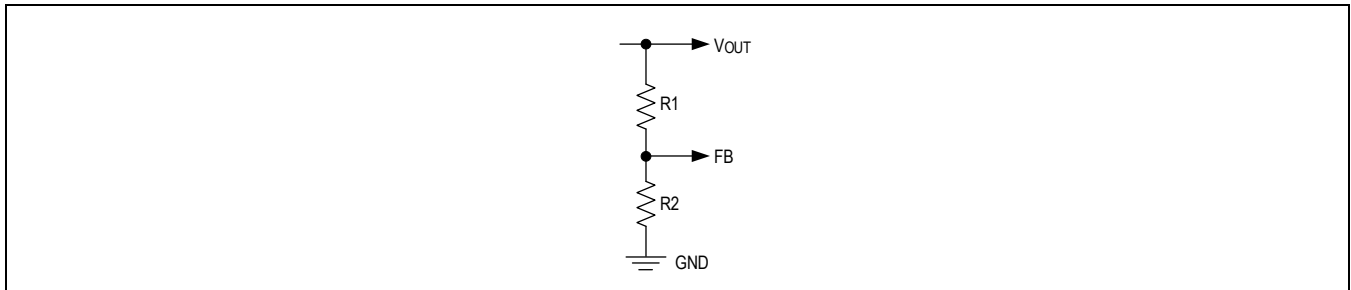

Figure 2. Setting the Output Voltage

Available Output Current Calculation

At a particular operating condition, the power loss that leads to the temperature rise of the part is estimated as follows:

$$P_{LOSS} = (V_{IN} - V_{OUT}) \times I_{LOAD}$$

where V_{IN} is the input voltage, V_{OUT} is the output voltage, and I_{LOAD} is the load current.

For a multilayer board, the thermal performance metrics for the packages are given in [Table 4](#).

The junction temperature of the ADPL42001 can be estimated at any given maximum ambient temperature (T_{A_MAX}) from the equation below:

$$T_J = T_{A_MAX} + (\theta_{JA} \times P_{LOSS})$$

Junction temperature greater than +125°C degrades operating lifetimes. Calculate the maximum allowable output current, using the following formula:

$$I_{\text{LOAD(MAX)}} = \frac{(125 - T_{\text{A_MAX}})}{\theta_{\text{JA}} \times (V_{\text{IN}} - V_{\text{OUT}})}$$

Example: $T_{\text{A_MAX}} = +70^{\circ}\text{C}$, $V_{\text{IN}} = 24\text{V}$, $V_{\text{OUT}} = 5\text{V}$, $\theta_{\text{JA}} = 42^{\circ}\text{C/W}$ for TDFN package

$$I_{\text{LOAD(MAX)}} = \frac{(125 - 70)}{42 \times (24 - 5)} \cong 69\text{mA}$$

Table 4. Thermal Resistance

PACKAGE TYPE	θ_{JA}	θ_{JC}	UNIT
6 TSOT	110	50	$^{\circ}\text{C/W}$
6 TDFN	42	9	$^{\circ}\text{C/W}$

Package thermal resistances were obtained using the method described in JEDEC specification JESD51-7, using a four-layer board.

TYPICAL APPLICATION CIRCUIT

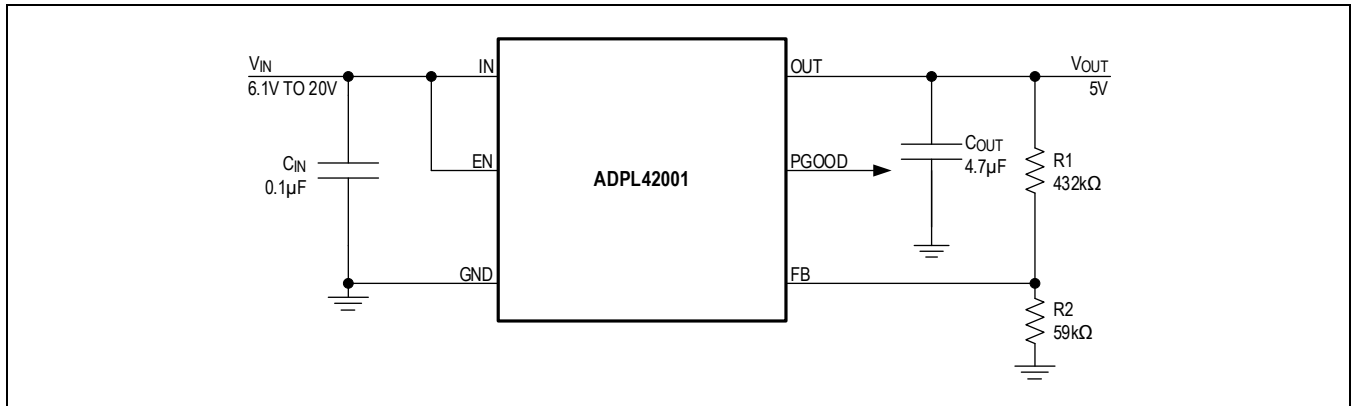

Figure 3. Application Circuit for 5V Output

OUTLINE DIMENSIONS

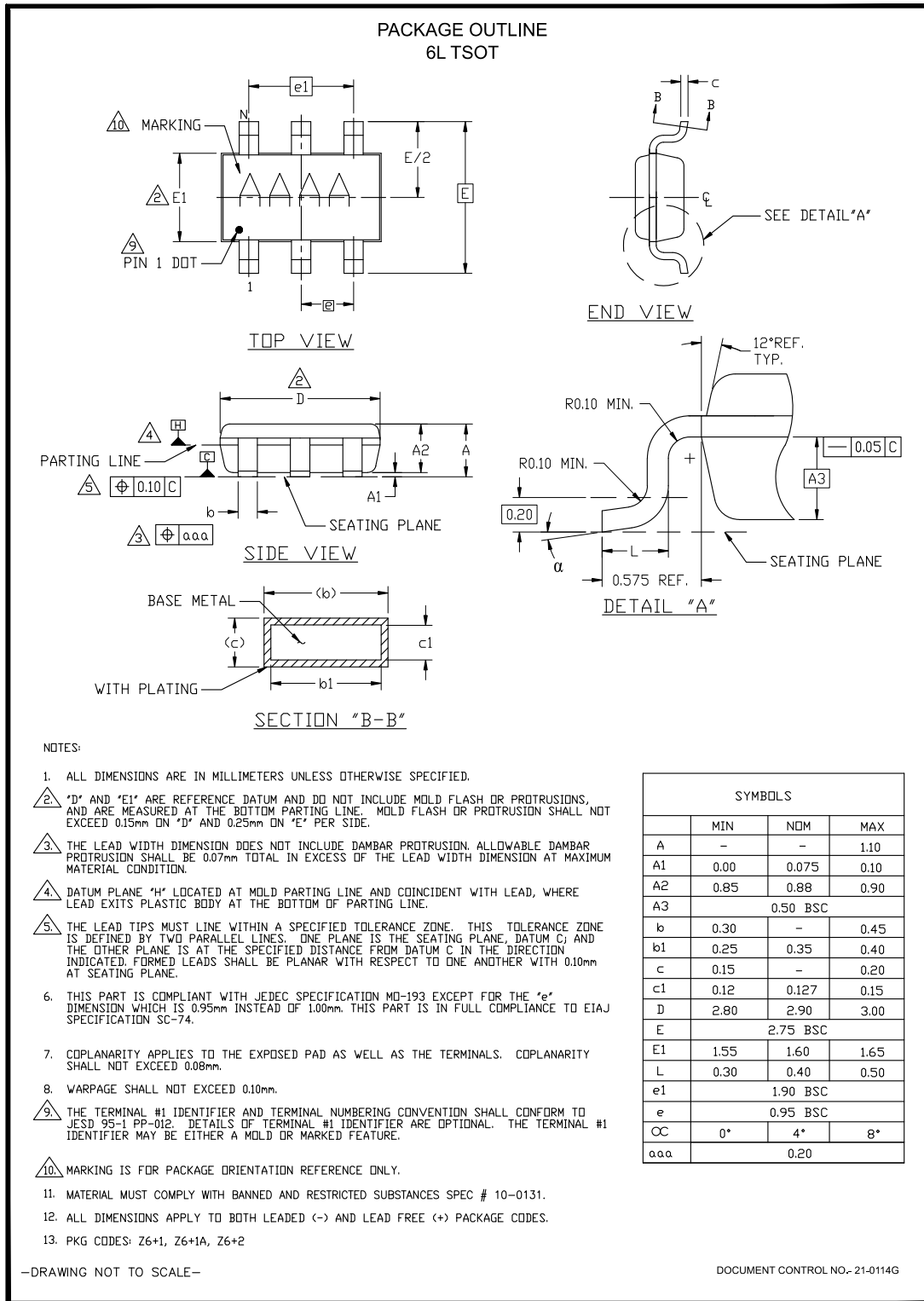

Figure 4. 6 TSOT Package Outline

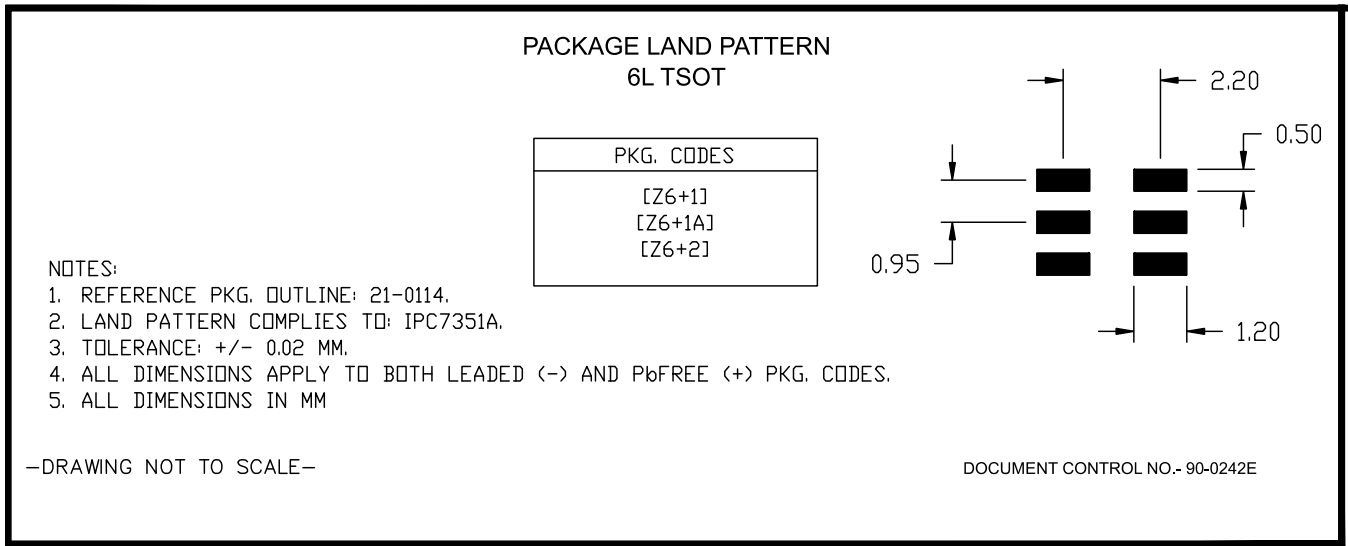

Figure 5. 6 TSOT Land Pattern

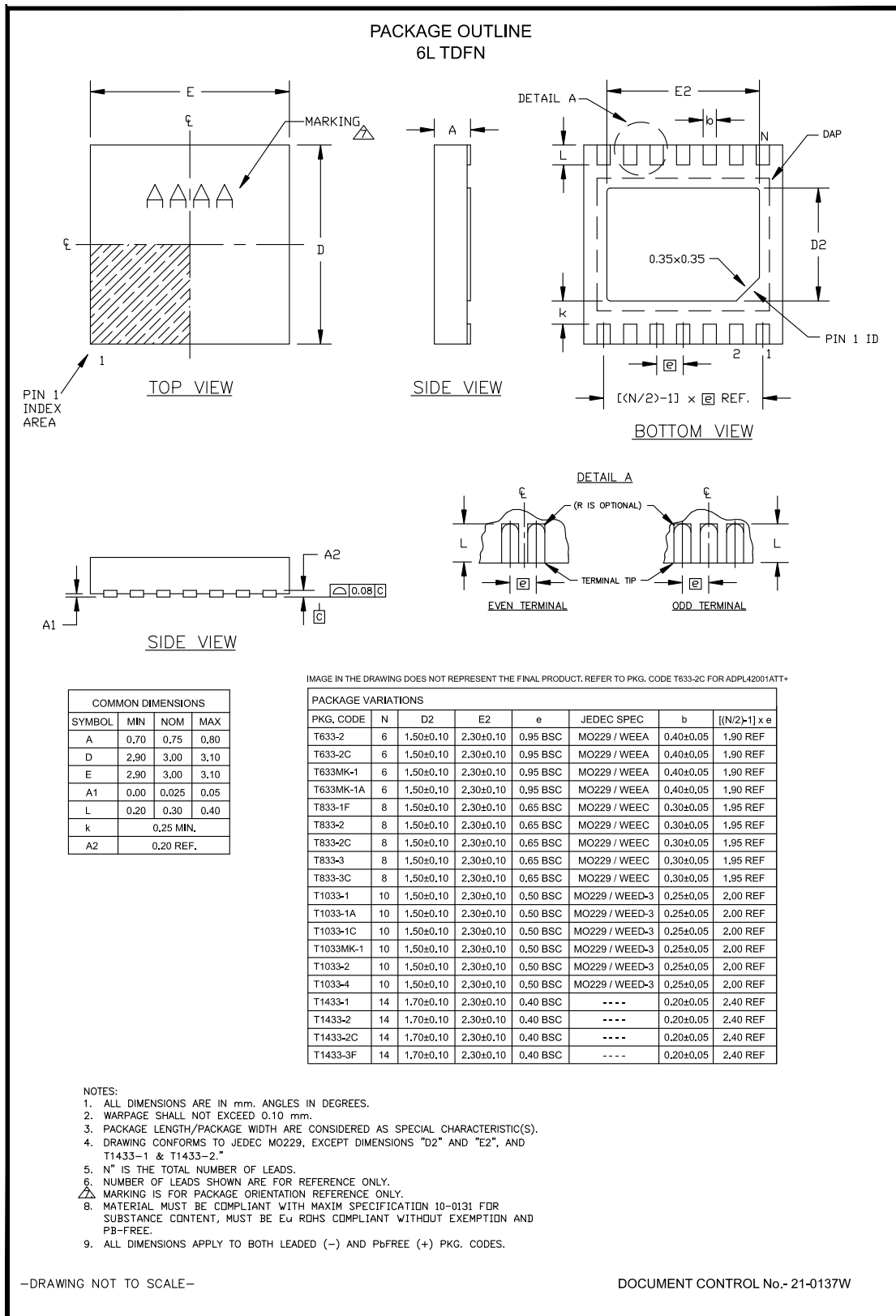

Figure 6. 6 TDFN Package Outline

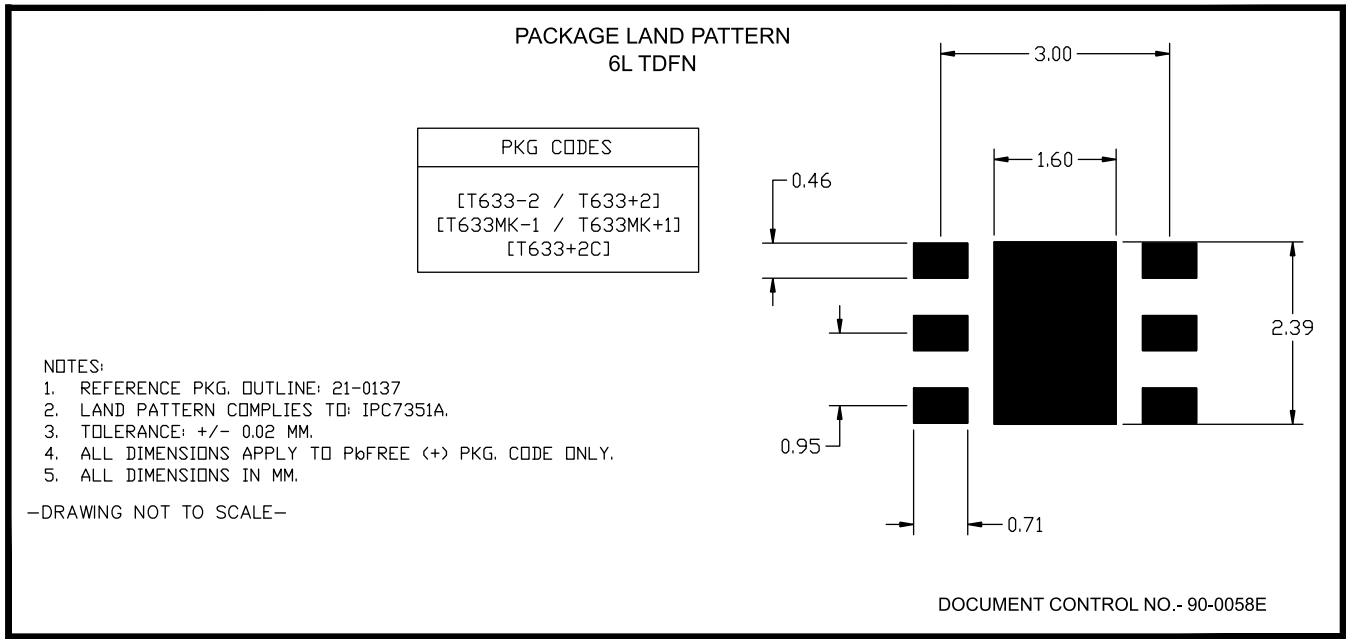

Figure 7. 6 TDFN Land Pattern

ORDERING INFORMATION

Table 5. Ordering Guide

PART	PIN-PACKAGE	TEMP RANGE
ADPL42001AZT+	6 TSOT	-40°C to +125°C
ADPL42001AZT+T	6 TSOT	-40°C to +125°C
ADPL42001ATT+	6 TDFN-EP*	-40°C to +125°C
ADPL42001ATT+T	6 TDFN-EP*	-40°C to +125°C

*EP = Exposed pad.

+Denotes a lead(Pb)-free/RoHS-compliant package.

T = Tape and reel.

REVISION HISTORY

REVISION NUMBER	REVISION DATE	DESCRIPTION	PAGES CHANGED
0	09/24	Initial release	—

ALL INFORMATION CONTAINED HEREIN IS PROVIDED "AS IS" WITHOUT REPRESENTATION OR WARRANTY. NO RESPONSIBILITY IS ASSUMED BY ANALOG DEVICES FOR ITS USE, NOR FOR ANY INFRINGEMENTS OF PATENTS OR OTHER RIGHTS OF THIRD PARTIES THAT MAY RESULT FROM ITS USE. SPECIFICATIONS ARE SUBJECT TO CHANGE WITHOUT NOTICE. NO LICENCE, EITHER EXPRESSED OR IMPLIED, IS GRANTED UNDER ANY ADI PATENT RIGHT, COPYRIGHT, MASK WORK RIGHT, OR ANY OTHER ADI INTELLECTUAL PROPERTY RIGHT RELATING TO ANY COMBINATION, MACHINE, OR PROCESS WHICH ADI PRODUCTS OR SERVICES ARE USED. TRADEMARKS AND REGISTERED TRADEMARKS ARE THE PROPERTY OF THEIR RESPECTIVE OWNERS. ALL ANALOG DEVICES PRODUCTS CONTAINED HEREIN ARE SUBJECT TO RELEASE AND AVAILABILITY.