

General Description

The MAX31091 evaluation kit (EV kit) is a fully assembled and tested PCB to evaluate the MAX31091 automotive temperature range spread-spectrum EconOscillator™. The EV kit operates from a single 3.3V supply. The EV kit also provides header pins to control the dither percentage (no dither, 1%, 2%, and 4%). An SMA connector for the clock output is included to easily facilitate the connection of test equipment.

EV Kit Contents

- Assembled circuit board including MAX31091AUA/V+033

Features

- Easy Evaluation of the MAX31091
- +3.3V Single-Supply Operation
- Proven PCB Layout
- Fully Assembled and Tested

[Ordering Information](#) appears at end of data sheet.

EV Kit Photo

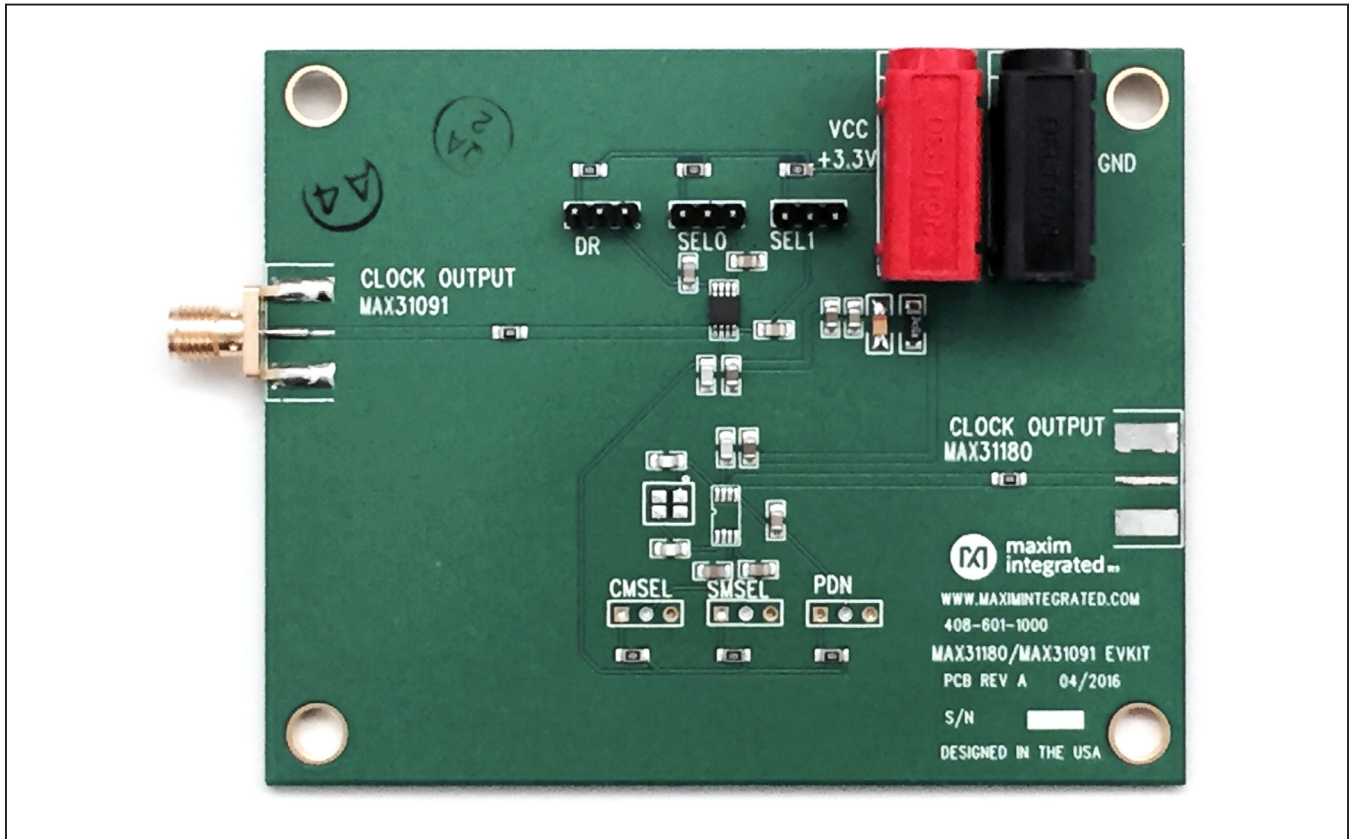

EconOscillator is a trademark of Maxim Integrated Products, Inc.

Quick Start

Required Equipment and Accessories

- One DC power supply capable of supplying +3.3V
- One multimeter for measuring the current
- One spectrum analyzer
- One SMA cable
- MAX31091 EV kit

Procedure

The EV kit is fully assembled and tested. Follow the steps below to verify board operation:

Note: To configure the SEL0 and SEL1, 3 pin Headers, set the jumper to the right side of the header for “0” position and left side for the “1” position

- 1) Place the EV kit on a nonconductive surface to ensure that nothing on the PCB is shorted to the workspace.
- 2) With the output set to +3.3V and disabled, connect the positive terminal of the DC supply through a mutimeter to the **red (VCC/+3.3V)** and negative terminal to **black (GND)** banana jacks of the MAX31091 EV kit.
- 3) Connect an SMA Cable to the MAX31091 CLOCK OUTPUT SMA connector of the MAX31091 EV kit and connect the other end of the cable to the spectrum analyzer.
- 4) Set the jumper on SEL1 on the position connected to GND (0).
- 5) Set the jumper on SEL0 on the position connected to GND (0). GND (0) position of the SEL1 and SEL0 set the Device Output to the “No dither” mode. [Table 1](#) shows the Dither Magnitude (percentage) of MAX31091AUA/V at different positions of the SEL1 and SEL0.
- 6) Set the center frequency of the spectrum analyzer to 33.3MHz, reference level to 30dBm, and span = 10MHz. [Table 2](#) shows the OUTPUT Frequencies of the different parts.
- 7) Turn on the power supply. Supply Current should be about 16mA ± 10% and spectrum analyzer should display a CW tone signal at 33.3MHz, if MAX31091AUA/V+033 installed. [Table 2](#) shows the Output frequency of the different parts.
- 8) Set the jumper on SEL0 on the position connected to VCC (1).
- 9) Leave the jumper on SEL1 on the position connected to GND (0). GND (0) position of the SEL1 and VCC (1) position of the SEL0 set the Device Output to the “1% dither” mode and spectrum analyzer displays a spread spectrum centered at 33.3MHz and about 666KHz bandwidth (± 1.0%), if MAX31091AUA/V+033 installed.

- 10) By setting the SEL1 and SEL0 at the positions showed on [Table 1](#), you can also see the spread spectrums with ± 2.0% and ± 4.0% dither.

Detailed Description

The MAX31091 is a clock generator with selectable dither magnitude and capable of output frequencies from 200kHz to 66.6MHz over the full automotive temperature range (-40°C to +125°C). The device can also produce a spread-spectrum (dithered) square-wave output using four pin-selectable dither percentages. The device also features two selectable dither rates.

The MAX31091 is shipped from the factory-programmed to a customer-specified frequency.

The MAX31091 can reduce radiated emission peaks. The dither percentage is controlled by the state of the SEL0 and SEL1 pins. The output frequency can be dithered at 0%, ±1%, ±2%, and ±4%, centered around the programmed frequency.

Table 1. Dither Magnitude

SEL1 LOGIC LEVEL	SEL0 LOGIC LEVEL	DITHER MAGNITUDE (%)
		MAX31091AUA
0	0	No dither
0	1	Q1 (1%)
1	0	Q1 (2%)
1	1	Q1 (4%)

Note: To configure the SEL0 and SEL1, 3 pin Headers, set the jumper to the right side of the header for “0” position and left side for the “1” position

Table 2. MAX31091AUA/V ICs and Output Frequencies

PART	OUTPUT FREQUENCY (MHz)
MAX31091AUA/V+033	33.3
MAX31091AUA/V+T033	33.3
MAX31091AUA/V+066	66.6
MAX31091AUA/V+T066	66.6
MAX31091AUA/V+172	1.7
MAX31091AUA/V+T172	1.7
MAX31091AUA/V+200	0.20
MAX31091AUA/V+T200	0.20
MAX31091AUA/V+330	33.0
MAX31091AUA/V+T330	33.0

Component Suppliers

SUPPLIER	WEBSITE
AVX	www.avx.com
Murata	www.murata.com
TDK	www.tdk.com
Del-Tron	deltron.com

Note: Indicate that you are using the MAX31091 when contacting these component suppliers.

MAX31091 EV Kit Bill of Materials

ITEM	QTY	REFERENCE	MANUFACTURER	PART NUMBER	DESCRIPTION	VALUE	PCB DECAL	NOTE
1	1	C1	AVX	TAJA476K006RNJ	Tantalum cap 10%	47uF	1206	
2	1	C6	AVX	TAJR106M006RNJ	Tantalum cap 10%	10uF	0805	
3	3	C3, C13, C15	Murata	GRM21BR71E104KA01L	Ceramic cap 10%	100nF	0805	
4	2	C9-10	Murata	GRM21A5C2E100JW01D	Ceramic cap 5%	10pF	0805	
5	4	C11-12, C14, C16	Murata	GRM216R71H102KA01D	Ceramic cap 10%	1nF	0805	
6	3	C2, C4-5	Murata	GCM21BR71E105KA56L	Ceramic cap 10%	1uF	0805	
7	2	C7-8	Murata	GRM2165C1H221JA01D	Ceramic cap 5%	220pF	0805	
8	2	R2-3	TDK		Resistor	0Ω	RES0805	
9	6	R1, R4-6, R15, R17	TDK		Resistor	1kΩ	RES0805	
10	1	JU1	Deltron	571-0500	Banana Jack Red			
11	1	JU2	Deltron	571-0100	Banana Jack Black		JACK	
12	3	TP1-TP2, TP5	DNP					
13	3	TP3, TP6-TP7	Digikey	609-3461-ND	3 pin Header		SIP13P	
14	1	J1 (CLOCK OUTPUT) MAX31180	DNP					
15	1	J2 (CLOCK OUTPUT) MAX31091	Cinch Conn	142-0701-801	SMA, Edge mount		SMAEDGE	
16	1	U1 (MAX31091)	Maxim	MAX31091AUA/V+033	IC		8UMAX	
17	1	U2 (MAX31180)	DNP					
18	1	Y1 (FA-238)	DNP					

MAX31091 EV Kit Schematic

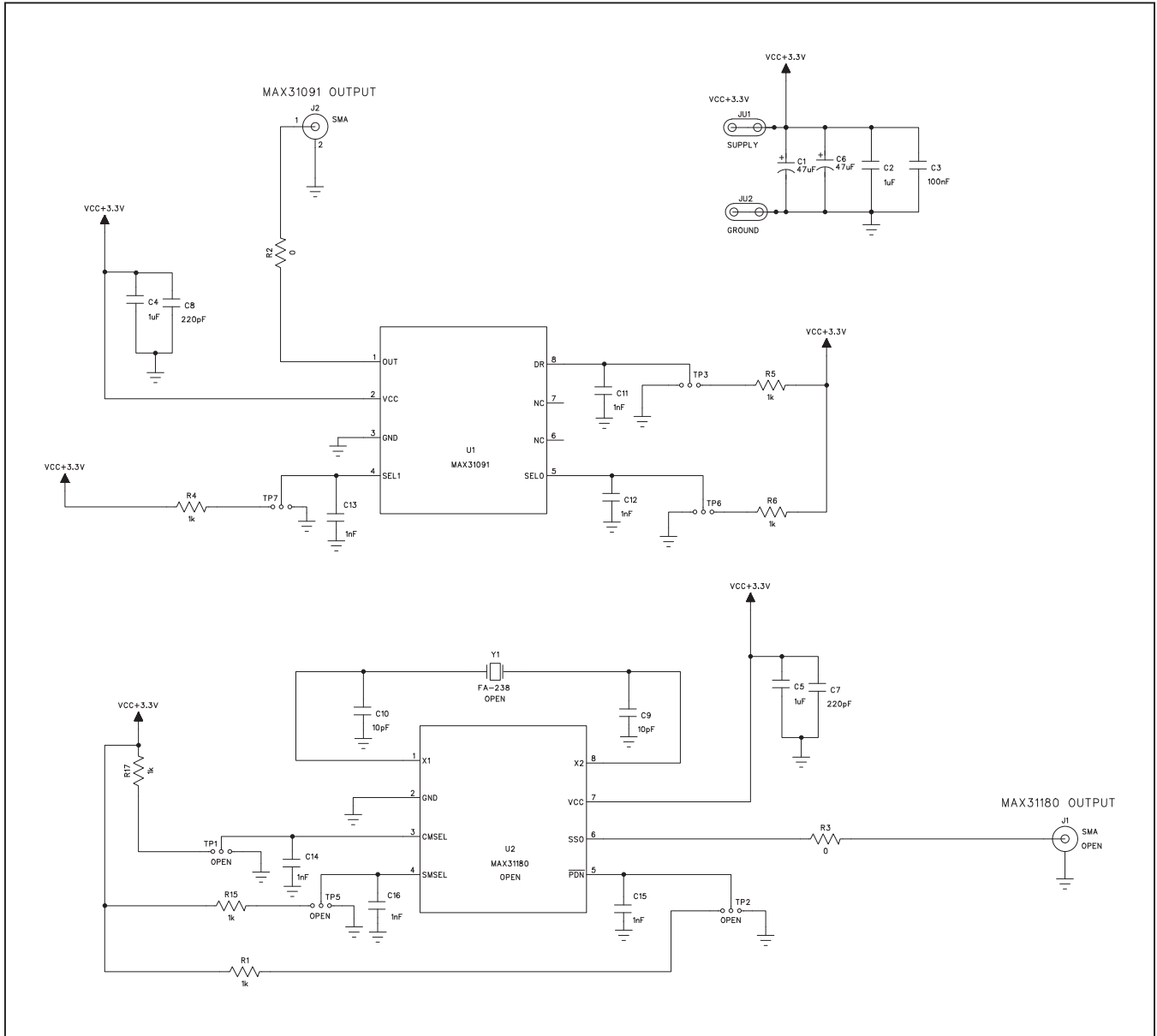

MAX31091 EV Kit PCB Layout Diagrams

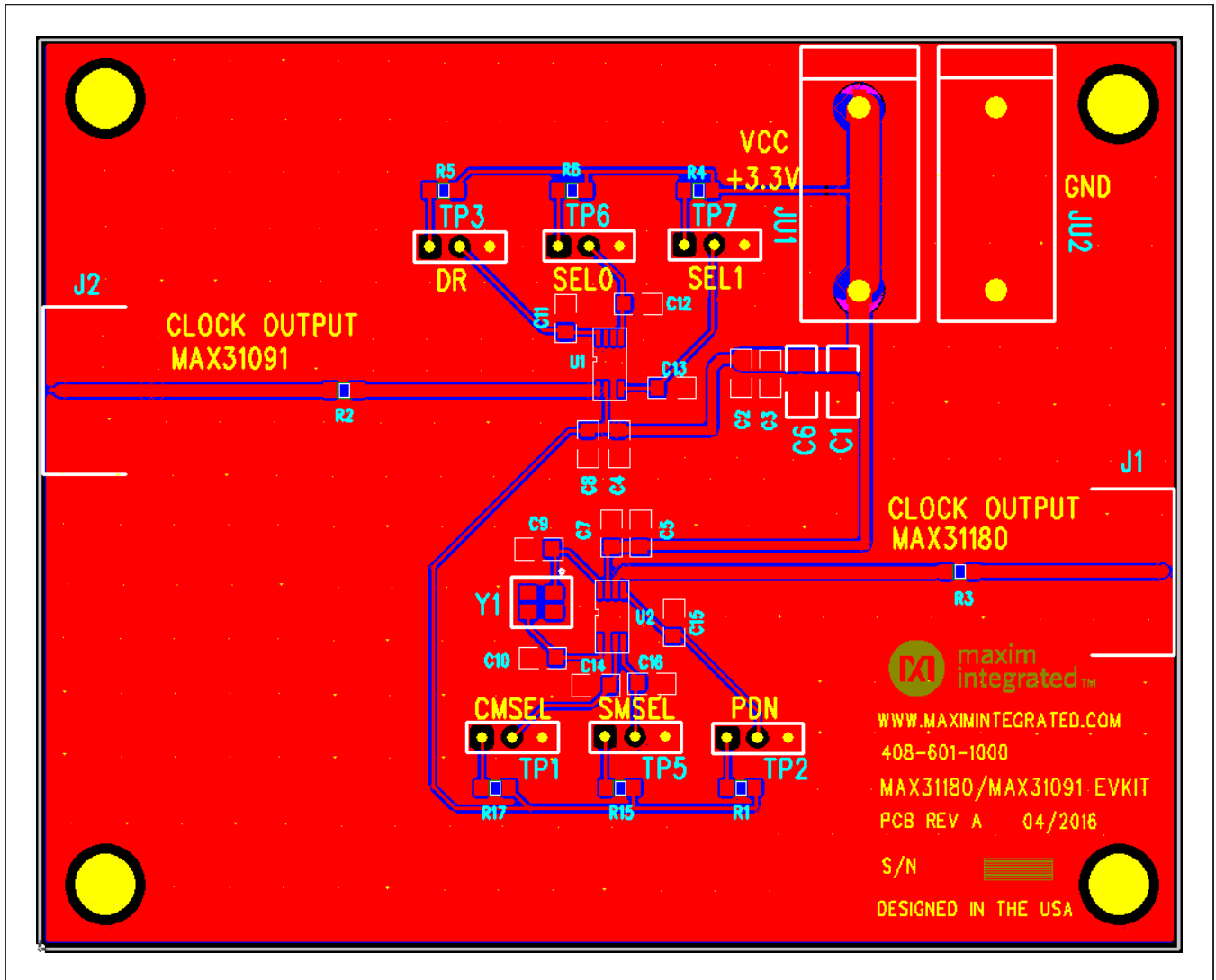

MAX31091 EV Kit—PCB Top Layer

MAX31091 EV Kit PCB Layout Diagrams (continued)

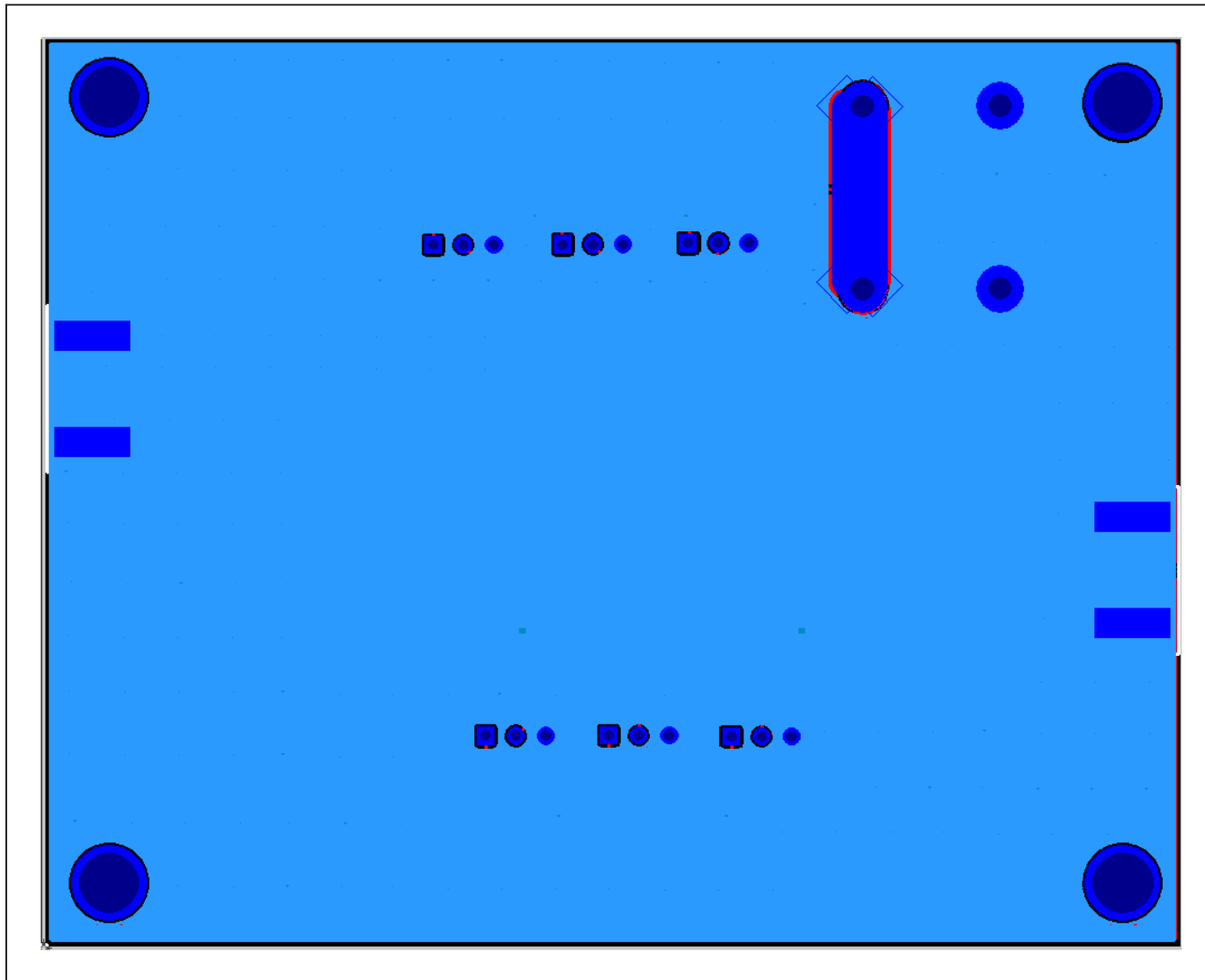

MAX31091 EV Kit—PCB Bottom Layer

Ordering Information

PART	TYPE
MAX31091EVKIT#	EV KIT

#Denotes RoHS compliant.

Revision History

REVISION NUMBER	REVISION DATE	DESCRIPTION	PAGES CHANGED
0	6/17	Initial release	—

For pricing, delivery, and ordering information, please contact Maxim Direct at 1-888-629-4642, or visit Maxim Integrated's website at www.maximintegrated.com.

Maxim Integrated cannot assume responsibility for use of any circuitry other than circuitry entirely embodied in a Maxim Integrated product. No circuit patent licenses are implied. Maxim Integrated reserves the right to change the circuitry and specifications without notice at any time.