

MAX190 Evaluation Kit

MAX190 EV KIT

EV Kit General Description

The MAX190 evaluation kit (EV kit) presents an 80C32-based hardware design that demonstrates the operation of the MAX190 low-power, single +5V-powered, 12-bit sampling analog-to-digital converter (ADC) in its serial interface mode.

The EV kit allows the user to select various MAX190 operating modes and perform conversions through an RS-232 data link. The results are displayed on an IBM-compatible personal computer running either a terminal emulator program or a dumb terminal.

The MAX190 EV kit can also demonstrate MAX191 performance. The MAX191 offers a few improvements over the MAX190, including a bipolar input range when used with dual supplies. It will perform the same as the MAX190 when used in the MAX190 EV kit. However, the evaluation kit cannot demonstrate the MAX191's bipolar feature. A MAX191 EV kit will be available by May 1993.

Features

- ◆ 12-Bit Resolution, 1/2LSB Linearity
- ◆ Proven Printed Circuit Board Layout
- ◆ Debugged Software Source Code
- ◆ Operates from a Single +6V to +10V Supply
- ◆ Built-In Track/Hold
- ◆ Interface to IBM-Compatible Computer through RS-232 Port

Ordering Information

PART	TEMP. RANGE	BOARD TYPE
MAX190EVKIT-DIP*	0°C to +70°C	Through-Hole

* Contact factory for availability

To evaluate the MAX191, order a free sample of the MAX191BCNG by calling toll free 1-800-998-8800 or returning on of the request cards found inside every A/D Converter Design Guide.

EV Kit

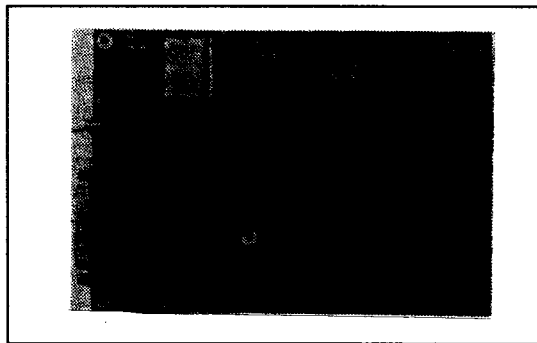

Functional Diagram

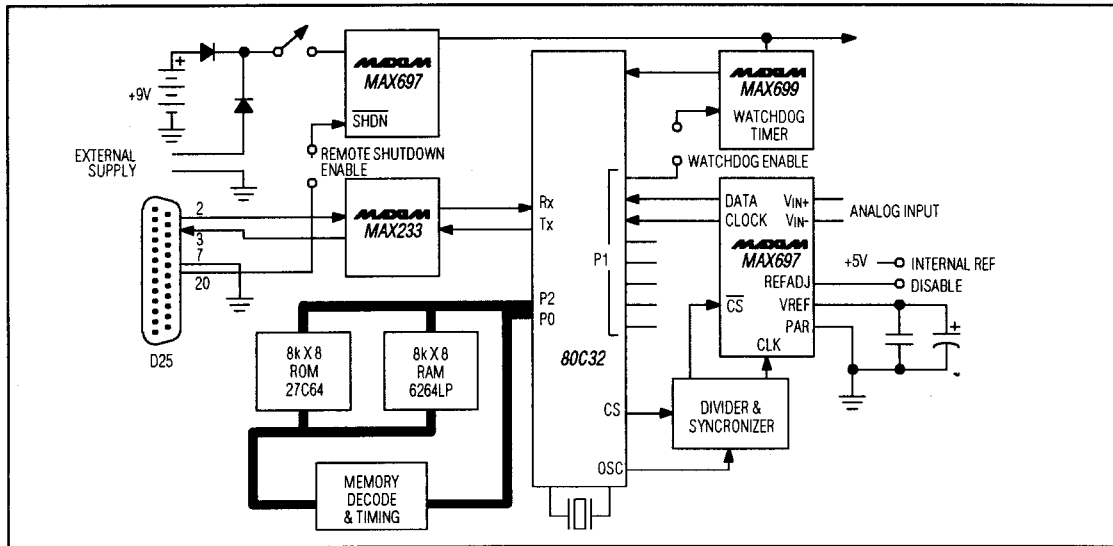

MAX190 Evaluation Kit

Component List

DESIGNATION	QUANTITY	DESCRIPTION
BT1	1	Battery holder
C3, C4	2	15pF capacitors
C1, C5-C7, C9-C13, C15, C18-C22	15	0.1 μ F capacitors
C8	2	47 μ F capacitors
C2, C17, C16	3	4.7 μ F capacitors
C14	1	100 μ F capacitor
CR1, CR2	2	1N4001 diodes
CR3, CR4	2	1N4148 diodes
CR5	1	1N5817 diode
J1	1	2-wire connector
	1	On-Shore Technologies' ED1603
J2	1	D25 female connector
JU1	1	3-pin header
JU2	1	2-pin header
Q1	1	2N7000
R1, R2, R4	3	100k Ω resistor
R3	1	10k Ω resistor
R5	1	10k Ω resistor
R6	1	20k Ω resistor
RP1	1	10k Ω 9-resistor SIP
RP2	1	100k Ω 9-resistor SIP
S1	1	Switch, SPST
	1	C&K 7101SD9ABE
U1	1	74HCT138
U2	1	80C32-P
U3	1	74HCT393
U4	1	74HC373
U5	1	MAX190
U6	1	MAX667
U7	1	MAX699
U8	1	27C64
U9	1	6264LP
U10	1	MAX233
U11	1	74HCT266
U12	1	74HC74
Y1	1	11.0592MHz CTS CTX078
None	1	28-pin IC socket
None	1	40-pin IC socket

Quick Reference

Setup and operation of the MAX190 EV kit involves the following steps:

1. Assemble the printed circuit board using the procedure in the *Assembly Instructions* section.
2. Copy the MAX190 EV kit floppy disk to another disk and store the original in a safe place. Use the copy for normal operation.
3. Read the README file for updates and changes.
4. Connect a cable between a serial port (COM1 or COM2) of the personal computer and the MAX190 EV kit printed circuit board. If a 25-pin (D25) connector is available, a straight-through cable can be used. If only a 9-pin (D9) connector is available, an adapter is required.
5. Start the SERCOMM program on the personal computer and set the indicated active port to agree with the cable location.
6. Turn on the printed circuit board power.
7. Type a SPACE to initialize communication with the EV kit board. The board should respond with a logon message. If not, refer to the trouble-shooting guide in this manual.
8. Enter a "?" for a list of available commands.
9. Connect the input signals to the analog input(s) and the system is ready for operation.

Detailed Description

Board Architecture

Power Supply

The evaluation board is powered by a 9V alkaline battery, such as an NEMA-1604A, or by an external DC power supply (not included).

The MAX667 low-dropout voltage regulator provides the +5V supply required by the other devices on the board.

The MAX667's shutdown feature can be used by the attached terminal's DTR signal to remotely turn the evaluation board on and off.

Supervision

The MAX699 low-cost power-on reset and watchdog-timer controller provides on-board system supervision for the microprocessor (μ P). The MAX699 generates a RESET signal at power-on and if the μ P's firmware fails to generate a transition at least once a second. Refer to the *Watchdog-Enable Jumper Block* section in this manual and the MAX699 data sheet for more information.

MAX190 Evaluation Kit

RS-232 Interface

The RS-232 interface connects an external terminal to the evaluation board. The MAX233 no-external-component, +5V-powered, dual RS-232 transmitter and receiver interface IC performs the level shifting required for the 80C32's integrated serial port.

One of the RS-232 receivers is not used in the design and is available for prototyping options.

Microprocessor

The 80C32 receives the user's commands over the RS-232 connection, performs the requested command, and then returns the results to the user over the RS-232 link. A full list of commands and responses is discussed in the *Commands Set* section.

Memory for the 80C32 is composed of a 27C64 8kbytes ROM and an optional 6264LP-15 8kbytes RAM. The ROM stores the 80C32's firmware (monitor). The RAM is used to buffer the results of analog-to-digital conversions. The firmware's 8051 assembly language source code is provided on diskette.

The memory-decoding circuitry has an associated jumper that determines the length of both the device enable signal sent to the ROM and RAM, and the extra memory decoding signals (2000-3FFF, 4000-5FFF, 8000-9FFF, A000-BFFF, C000-DFFF, E000-FFFF), which are provided for prototype expansion. The *Jumper Options* section discusses the setting of this jumper.

The 80C32's 8-bit data bus and the control signals ($\overline{\text{PSEN}}$, $\overline{\text{RD}}$, $\overline{\text{WR}}$, & $\overline{\text{ANYRD}}$) are provided at labeled pads for prototyping.

The 80C32's PORT 1 (P1) is a general-purpose input/output (I/O) port. The bits have been assigned the following uses:

- Bit 0 - Serial data from the MAX190
- Bit 1 - Serial clock from the MAX190
- Bit 2 - Chip select to the MAX190
- Bit 3 - High-byte enable to the MAX190
- Bit 4 - Read to the MAX190
- Bit 5 - Bipolar input select to the MAX190
- Bit 6 - Power-down to the MAX190
- Bit 7 - Programmed heartbeat to the MAX699 watchdog

The user can cut the power-down jumper, discussed in the *Jumper Options* section, and use Bit 6 for other purposes.

The 80C32 uses an 11.0592MHz crystal. This frequency allows the μP to execute most of its instructions in 1.085 μs , and provides an exact integer multiple for the standard baud rates.

Frequency Divider and Synchronization Circuit

The μP 's oscillator output is sent to a 74HCT393 for predivision. Running the MAX190 from a clock signal that is derived from and synchronized with the μP 's clock minimizes the amount of digital noise induced into the ADC. The 74HCT393's output (A2D FAST CLK) is sent to a 74HC74.

The 74HC74 provides two functions. First, it divides the A2D FAST CLK by two to produce A2D CLK at a frequency of 86,400kHz with a 50% duty cycle. This is a relatively low clock frequency for the MAX190. However, it is about as fast a frequency as the 80C32 can keep up with when the 80C32 inputs the serial data with a firmware routine. The driver firmware will be discussed later. Second, it synchronizes the asynchronous chip-select request from the μP (A2D-CS) with the ADC's clock (A2D CLK). The MAX190 design specifies its chip select occurring no earlier than 5 μs before, and no later than 50 μs after the falling edge of the clock.

MAX190 Low-Power, Single-Supply, 12-Bit Sampling ADC

The MAX190's analog input pins are brought out to a pair of solder pads marked AIN+ and AIN-. The solder mask indicates on which pads an input resistor (R3) and a filter capacitor (C10) can be installed to form a lowpass filter. Typical values for these parts are 10k Ω and 0.1 μF . A shorting trace by the MAX190's AIN+ pin must be cut when R3 is installed.

The EV kit's jumper, marked -AIN:GND, connects AIN- to analog ground. This jumper must be cut for the MAX190 to operate in the pseudo-differential input mode. See the *Pseudo-Differential Input* section of the MAX190 data sheet for a discussion of this mode.

Pads and jumpers are provided to allow external reference voltage adjustments.

Firmware Structure

The source code for the evaluation board's firmware is provided on a diskette. The program is in assembly language and operates with an 80C32 assembler. The program being executed on the board will be referred to as the monitor.

MAX190 Evaluation Kit

The monitor enters its main control loop after initialization. This code starts at the label main. Main calls "get_command" which handles keyboard entry for the monitor. Commands that simply change the state of the monitor (for instance the "H" command, which is used to set the output mode to hexadecimal) are handled within the "get_command." Commands requiring action, such as making analog-to-digital conversions or testing RAM, return function request codes to main. Main then calls the function associated with the request code.

The monitor can be extended by the user to add new commands or to modify the existing ones. The easiest way to extend the monitor is to add a new command recognition to "get_command" and have it return a new function request code.

There are some general-purpose functions in the monitor that are useful if you choose to modify it. These include functions to write a byte- or null-terminated string to the terminal, functions to perform analog-to-digital conversions, and a function to display the results of the conversions.

80C32/MAX190 Interface

The MAX190 is connected to the 80C32 with the μ P's 8-bit data bus and communicates serially. The following code sequence is extracted from the source code and demonstrates the bit-banging serial interface. The MAX190 is commanded to do a conversion in the current mode (BIP or UNI).

The results are stored in 1E and 1F registers, a2d_hi and a2d_low respectively.

Application Information

Attaching the Terminal

The board operates as data communications equipment (DCE), referred to as a modem, and expects to be connected to data terminal equipment (DTE). A standard modem cable attaches the board to a personal computer running emulation software or a straight-through cable connects the board to a dumb terminal. Maxim supplies a terminal emulation software package called Sercomm, but any terminal emulation software is acceptable.

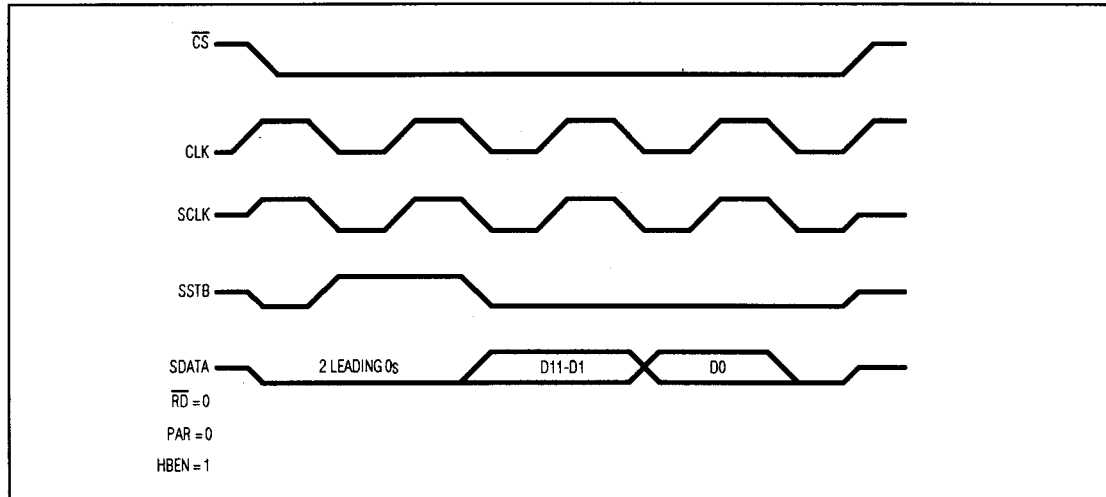

Figure 1. Timing Diagram

MAX190 Evaluation Kit

MAX190 EV KIT

MAX190 Code Listing

```
IO_PORT      reg      P1
SDATA        equ      01h      ; A2D's Serial Data bit
b_SDATA      reg      P1.0
SCLK         equ      02h      ; A2D's Serial Clock bit
b_SCLK       reg      P1.1
nCS          equ      04h      ; A2D's Chip Select (neg true)
b_nCS        reg      P1.2
nHBEN        equ      08h      ; A2D's High-Byte Enable (neg true)
b_nHBEN      reg      P1.3
nRD          equ      10h      ; A2D's Read Enable (neg true)
b_nRD        reg      P1.4
BIP          equ      20h      ; A2D's Bipolar (not unipolar) Select
b_BIP        reg      P1.5
PD           equ      40h      ; A2D's Power-Down
b_PD         reg      P1.6
TIC_TOC      equ      80h      ; Watchdog-timer reset pulse
b_TIC_TOC    reg      P1.7

START        equ      SDATA+SCLK+PD+nHBEN+TIC_TOC
STOP         equ      SDATA+SCLK+PD+nHBEN+nCS

a2d_start    reg      1ch      ; Starts A2D conversion pattern
a2d_stop     reg      1dh      ; Ends A2D conversion pattern
a2d_hi       reg      1eh      ; A2D conversion result MSB
a2d_low      reg      1fh      ; A2D conversion result LSB

;      Register 20 holds the output-mode flags.

output_flags reg      20h
hex_flag     reg      20h.0    ; Set if in HEX output mode
dec_flag     reg      20h.1    ; Set if in ASCII output mode
bin_flag     reg      20h.2    ; Set if in BINARY output mode

;      Register 21 holds other general-purpose flags.

gp_flags     reg      21h
bip_flag     reg      21h.0    ; Set=bipolar; reset=unipolar
ram_present  reg      21h.1    ; Set=sample & dump are OK

READ_BIT     macro
clr          C                ; Clears the carry
$1:          jnb   b_SCLK, $1   ; Waits for the CLOCK to rise
            orl   C, b_SDATA    ; Moves the data to carry
            rlc   A                ; Rotates it in
$2:          jb   b_SCLK, $2   ; Waits for clock to drop
            endm
```

MAX190 Evaluation Kit

MAX190 Code Listing (continued)

```

convert      equ      $
              ; Establishes the start and stop PORT-1 bit patterns.

              mov      A, #START
jnb          bip_flag, con_1
              orl      A, #BIP
con_1        mov      a2d_start, A

              mov      A, #STOP
jnb          bip_flag, con_2
              orl      A, #BIP
con_2        mov      a2d_stop, A

              ; Starts a conversion

              clr      A          ; Clears the accumulator
              mov      IO_PORT, a2d_start ; Starts the conversion

              ; Gets the leading zeros and the first 6 bits

rd_bit_lz1   READ_BIT
rd_bit_lz2   READ_BIT
rd_bit_11    READ_BIT
rd_bit_10    READ_BIT
rd_bit_9     READ_BIT
rd_bit_8     READ_BIT

              mov      a2d_hi, A      ; Stores MSByte in bit order:
                                      ; 7 6 5 4 3 2 1 0
                                      ; 0 0 LZ LZ 11 10 9 8

              ; Fetches the remaining 8 LSbits

rd_bit_7     READ_BIT
rd_bit_6     READ_BIT
rd_bit_5     READ_BIT
rd_bit_4     READ_BIT
rd_bit_3     READ_BIT
rd_bit_2     READ_BIT
rd_bit_1     READ_BIT
rd_bit_0     READ_BIT

              mov      a2d_low, A     ; Fetches MSByte

              mov      IO_PORT, a2d_stop

ret

```

MAX190 Evaluation Kit

MAX190 EV KIT

The following diagrams show the connections between the terminal and the MAX190 EV kit.

For D25 (25-pin) to D25 connectors (standard adapters are available for this configuration):

Terminal Connector (DTE)		MAX190 Connector (DCE)	
Signal	Pin	Pin	Signal
Ground	1	1	Ground
TxD	2	2	TxD
RxD	3	3	RxD
RTS	4	4	RTS
CTS	5	5	CTS
DSR	6	6	DSR
Ground	7	7	Ground
DCD	8	8	DCD
DTR	20	20	DTR
(RI)	22	22	(RI)

For D9 (9-pin) to D9 connectors (standard adapters are available for this configuration):

Terminal Connector (DTE)		MAX190 Connector (DCE)	
Signal	Pin	Pin	Signal
DCD	1	8	DCD
RxD	2	3	RxD
TxD	3	2	TxD
DTR	4	20	DTR
Ground	5	7	Ground
DSR	6	6	DSR
RTS	7	4	RTS
CTS	8	5	CTS
(RI)	9	22	(RI)

For Macintosh mini 8-pin DIN to D25 connectors:

Terminal Connector (DTE)		MAX190 Connector (DCE)	
Signal	Pin	Pin	Signal
DTR	1	20	DTR
CTS	2	5	CTS
TxD	3	2	TxD
Ground	4	7	Ground
RxD	5	3	RxD
not used	6		
not used	7		
not used	8		

The board supplies a fixed DATA SET READY (DSR), CLEAR TO SEND (CTS) and CARRIER DETECT (CD) to the interface at all times when it is powered up.

The board ignores the REQUEST TO SEND (RTS) signal from the terminal. The signal is brought out at RS-232 voltage levels to a pad marked RTS, and this line can be used for prototyping.

As the board is shipped, the DATA TERMINAL READY (DTR) signal is also ignored by the board. If the DTE-CTL jumper is cut, however, use DTR to turn the board on and off, assuming the on/off switch is in the on position. This option causes the board to power-down when you turn off your dumb terminal or exit your terminal emulation program, thus extending battery life. This function is useful for battery-operated systems.

Autobaud

Before turning on the evaluation board, set your terminal for an 8-bit, no-parity, full-duplex operation. You can set your terminal to any standard baud rate from 300Bd to 9600Bd.

Maxim supplies the Sercomm terminal emulation program for operation with Maxim's EV kits. The SERCOMM.EXE program on the diskette can be copied to a hard disk drive or started from the floppy disk. The program will display a help menu for the available options.

When the board is first powered up, the firmware does some initialization and then enters an automatic baud-rate detection mode. The autobaud routine examines the first character received to determine the incoming baud rate.

THE FIRST CHARACTER RECEIVED BY THE BOARD AFTER POWER-UP MUST BE A SPACE.

The space character (20 hex) is expected by the autobaud routine. Sending a different character will cause the autobaud function to calculate a different baud rate from that of your terminal, and gibberish will appear on your screen. If you inadvertently press some other key first, turn the board off to correct the problem.

Once the communication link is established, the monitor displays its sign-on banner and a prompt. The banner consists of the copyright notice and the ROM version information. The message will look something like this:

```
Copyright MAXIM INTEGRATED PRODUCTS, 1992
Version 1.00 Released January 9, 1992
```

Type "?" for the help menu

After the log-in procedure is completed, the system displays a descriptive prompt.

Prompt

The monitor's prompt takes the form:

```
MAX190: <current output format:current input mode>
```

where the current output format can be HEX, DEC or BIN, and the current input mode is either UNI or BIP.

MAX190 Evaluation Kit

The monitor has commands to set the current output and input modes. These commands are discussed in the *Command Set* section.

You can determine the monitor's current operating mode by simply looking at the prompt. For instance, if the prompt reads

```
MAX190:HEX:BIP >
```

you know the MAX190 is encoding data using signed twos-complement 12-bit coding (presumably in pseudo-differential mode) and the output format is in ASCII hexadecimal.

Command Set

The monitor has an 8-byte input buffer. You will receive the monitor's error message "?" if more than 8 characters are sent to the monitor without an ENTER (carriage return). You will also receive the error message if the monitor receives an unknown command. All commands are single characters followed by ENTER (carriage return). The "?" command accesses help. The help screen lists all of the commands displayed in functional groups, as follows:

? - Help screen

Display Output Mode Selection Commands:

- H - Hexadecimal format
- D - ASCII decimal format
- ^B - Binary values (12bits/2bytes, MSByte 1st)

MAX190 Conversion Mode Selection Commands:

- B - Bipolar mode
- U - Unipolar mode

Make Conversion Commands:

- M - Makes a single conversion and displays result. A carriage return with no other character also makes a conversion.
- C - Continuously converts and displays until key is pressed

RAM Related Commands:

- R - RAM test
- S - Stores conversions in RAM buffer until full
- O - Outputs the values stored in RAM buffer

The RAM related commands "S" and "O" appear only if the RAM chip is present on the evaluation board.

The Display Output Mode Selection commands are used to set the display format of the result of MAX190 conversions. When the MAX190 performs a conversion, the result is always 12 bits long. The 12 bits of data are presented as follows:

H - Hexadecimal format

The 12-bit value is converted into ASCII hexadecimal format with a dynamic range of 000 to FFF. The present input mode has no effect on the output data in HEX mode. This means that FFF equals a count of -1 in the bipolar (BIP) mode or 4095 counts in the unipolar (UNI) mode.

D - ASCII decimal format

The 12-bit value is converted into ASCII decimal format. The dynamic range depends on the current input mode, as follows:

INPUT MODE	DYNAMIC RANGE
Unipolar (UNI)	0 ... 4.095
Bipolar (BIP)	-2.048 ... 2.047

^B (Control B) - Binary values (12bits/2bytes, MSByte 1st)

The ^B command causes the binary values to be output as raw binary data (i.e. unformatted) in a 2-byte packet. The first byte has four leading zeros followed by the conversion's most significant 4 bits. The second byte holds the conversion's least significant 8 bits.

As with the HEX output mode, the input mode does not change the format of the data. The dynamic range of the output, expressed as a binary-bit pattern, is:

```
0000 0000 0000 0000 ... 0000 1111 1111 1111
```

Input mode is useful when capturing data to a disk log file, but do not send this data to your display screen because the binary values will have unpredictable control effects on your screen.

The Conversion Mode Selection commands are used to tell the MAX190 which data transfer function it should use to present the conversion result.

B - Bipolar mode

In bipolar mode, the MAX190 outputs a signed 12-bit twos-complement number. The MAX190 is now operating in pseudo-differential mode, and the AIN- to analog ground jumper is cut open. See the MAX190 data sheet for a discussion of pseudo-differential input, output data format, dynamic performance, and unipolar/bipolar transfer functions.

U - Unipolar mode

Unipolar mode is the monitor's default operating mode. The input voltage is expected to range from 0V to +4.095V.

MAX190 Evaluation Kit

MAX190 EV KIT

The main function of the EV kit is to make the MAX190 perform a conversion and to display the results.

M - Makes a single conversion and displays result. A carriage return with no other character also makes a conversion.

The MAX190 is commanded to make one conversion in the current input mode, and the result is displayed in the current output mode.

C - Continuously converts and displays result

Like the M command, conversions are performed, but they continue until any key is pressed.

If your terminal cannot accept the data at full speed, data will be lost. The XOFF or any other character will terminate this command. If you have a problem, try operating your terminal at a slower baud rate. This warning also applies to the RAM output 'O' command.

The RAM Related commands are useful when the optional 8kbyte RAM chip is installed in the evaluation board.

R - RAM test

The monitor continuously fills the RAM with the following bit patterns, and then reads the data back to verify RAM integrity:

BINARY	HEX
00000000	00
11111111	FF
01010101	55
10101010	AA

The RAM test runs until the monitor receives any character. The results are displayed as errors, which are detected at the beginning of each test pattern run.

S - Stores conversions in RAM buffer until full

4096 conversions are made in the current mode (UNI or BIP), and the results are stored in the RAM as raw 12-bit data.

O - Outputs the values stored in RAM buffer

The RAM's current contents are formatted per the current output mode (HEX, DEC or BIN), and the results are sent to the terminal.

There are a few things to keep in mind when outputting the contents of the RAM buffer. If you use decimal formatting, DO NOT change between UNI and BIP input modes between the time you take a sample (S) and do the output (O), because the output coding will not match the input coding.

Power Requirements

The MAX190 evaluation board can be powered by a 9V alkaline battery, such as an NEMA 1604A, or by an external

DC power supply. If an external power supply is used, the input voltage should be between 6.30V and 11.0V. Keep the input voltage at or below the high limit. The more current that is required, the lower the input voltage should be, due to power dissipation limitations of the package. For additional information refer to the MAX667 data sheet.

The evaluation board draws 50mA to 80mA when operating with normal memory-cycle lengths. The current requirements increase with extended memory-cycle decoding and with current demands of the circuitry added in the prototype area. The total current load must not exceed the limits of the MAX667. Refer to the MAX667 data sheet if additional current is required.

Jumper Options

Two jumper blocks permit shunts to be set on or off to affect the board's operation. In addition, three traces that can be cut, and a wire jumper can be soldered in to set options on the board.

Cycle-Length Jumper Block

In the normal configuration, the address decoder's output (U1, 74HCT138) is asserted only for the duration of the 80C32's RD, WR or PSEN signals. This enables the ROM and RAM devices only for short periods of time.

If U1's pin 5 is grounded, the output stays asserted from the time memory in a specific block is first accessed until memory in another block is accessed. This increases the board's current requirements to approximately 150mA, and the input voltage range must be limited (see the MAX667 data sheet). It is recommended that this operation be used only if additional circuitry require long address-enable signals.

Watchdog-Enable Jumper Block

The watchdog-enable jumper block is normally installed. In this watchdog-enable mode, the μ P automatically resets if its firmware fails to send a heartbeat to the watchdog. Remove this jumper to defeat the automatic reset feature during firmware development.

DTE Control Jumper

If the DTE control jumper is cut, use the terminal's DTR signal to turn on the evaluation board and to reset it. The board ignores DTR if the jumper is not cut.

External Reference Jumper

The internal reference jumper is open when the board is shipped, which enables the internal reference. Soldering a wire between the pads to +5V disables the internal reference and allows the use of an external reference at the MAX190's VREF pin.

MAX190 Evaluation Kit

Analog Ground

As shipped, the MAX190's AIN- input is connected to AGND with a jumper. Cut this jumper to use the pseudo-differential input (BIP).

When using BIP mode, cut the AIN- to ground jumper. Then offset the AIN- input to +2.5V for proper BIP mode operation.

Assembly Instructions

The MAX190 EV kit is shipped unassembled. To assemble the kit you will need a small-tipped, grounded soldering iron, wire cutters, and a screw driver. You should have basic prototyping skills such as soldering and determining component values. Follow the directions carefully and verify your work at each step.

Trim the leads of the diodes, resistors and capacitors after they have been soldered in position.

1. Remove the board and parts from the box and verify that all components on the parts list are present.
2. Insert and solder the diodes in place. Be sure to align the cathode band on the diode with the markings on the printed circuit board.

CR1, CR2	1N4001
CR3, CR4	1N4148
CR5	1N5817

3. Insert and solder the resistors.

R1, R2, R4	100kΩ 5%
R6	20kΩ 5%
R3, R5	10kΩ 5%
4. Insert and solder the 28-pin socket for U8, the 27C64 ROM.
5. Insert and solder the 24-pin socket for U5, the MAX190.
6. Insert and solder the non-polarized capacitors.

C3, C4	15pF
C1, C5-C7, C9-C13,	
C15, C18-C22	0.1μF

7. Insert and solder the polarized capacitors. MAKE SURE THE POSITIVE TERMINAL OF THE CAPACITOR ALIGNS WITH THE POSITIVE PAD (marked with a + sign).

C2, C16, C17	4.7μF
C8	47μF
C14	100μF

8. Insert and solder the 11.059MHz crystal.

9. Mount and solder into position the power switch, the power connector (J1), and the 25-pin RS-232 connector (J2).
10. Mount the battery holder into position using the two-sided tape. Make sure the two terminal leads go through the board. Solder the terminal leads.
11. Insert and solder the two resistor SIP packages RP1 and RP2. Align the marked end of the SIP with the end of the outline marked with a bar.

RP1	10kΩ
RP2	100kΩ
12. Insert and solder the 2N7000 transistor. Align the case with the outline drawn on the printed circuit board.
13. Insert and solder the 2-pin header on JU2, Watch-dog Enable. Place a shunt across the two pins.
14. Insert and solder the 3-pin header on JU1, Cycle Length. Place a shunt across the two inside pins.
15. Insert and solder the following devices. Align the notched end of the package with the notched end of the outline on the board.

Sockets may be soldered in for each device.

U1	74HCT138
U2	80C32
U3	74HCT393
U4	74HCT373
U6	MAX667
U7	MAX699
U9	6264
U10	MAX233
U11	74HCT7266
U12	74HC74

16. Insert the 27C64 ROM at U8 and the MAX190 at U5 into their sockets.

When assembly has been completed, carefully examine the board for mis-inserted components and soldering faults. Remove excess flux and read the setup instructions.

Proceed to the Setup Section for board operations.

Trouble-Shooting Guide

Digital Section

With a terminal attached to the D25 connector, apply power to the evaluation board. Type a space before typing any other character. You should see the sign-on banner displayed on your screen in response to the space. If you do not get the sign-on banner, use the following suggestions to isolate the problem.

MAX190 Evaluation Kit

MAX190 EV KIT

If gibberish appears, either the terminal is not set to 8-bit, no-parity operation, or the first character sent to the board was not a space. Reset the board and press the spacebar. If each character that you type appears twice on the terminal, you are in half-duplex mode. Change the setting to full duplex.

If there is no response, check the following:

Terminal Connection

Remove the RS-232 cable from the evaluation board and connect pins 2 and 3 together. When you type on the terminal, you should see the characters echoing on the screen. If not, the problem is somewhere in the terminal or cable.

Power

Is there 5V on the +5V prototype pads? Measure the +5V on the printed circuit board. Measure between the DGND and +5V traces found on the edge of the prototype area. If it is lower than 4.95V, verify the following:

Make sure the switch is turned on.

Verify that the input voltage to the MAX667 (pin 8) is greater than 6.0V. If not, the problem is the power source.

Are you using a battery? Is the battery good? Try a new 9V alkaline battery. Its loaded output voltage is typically greater than 7V.

If you are using an external power supply, is it turned on and connected with the proper polarity (positive to VIN)?

If the MAX667 input (pin 8 > 6V) is okay but its output (pin 2) is low, check the following:

Has the DTE-CTL trace been cut to enable DTR control of power? If YES, is DTR being asserted by your terminal? Reconnect the DTE-CTL pads and try again. Pin 5 of the MAX667 needs to be pulled down to 0V to operate.

If the MAX667 output is 0V and it is warm, the output might be shorted. Examine the board for shorts and verify that all devices are inserted correctly.

Microprocessor-Related Problems

If the 5V supply is okay, use a scope to check pin 5 of U3 (the 74HCT393) to verify that the oscillator is running. If not, the 80C32 or the reset circuit could be at fault.

Verify that P1.0 (pin 1 of the 80C32) toggles regularly. If not, the basic digital system is not operating properly. Check the following:

Verify that the reset circuit is operating properly. Pin 7 of the MAX699 should be low for 140ms to 500ms after power-up, then go high. If not, make sure its output is not overloaded.

Verify that the ADO address line has a signal on it. If the μ P is functioning properly, the address line will change states regularly.

Verify that the μ P control lines are not overloaded. With a scope, observe the operation of the PSEN, ALE, WR, and RD lines. The first two will toggle about every microsecond. The WR and RD lines will remain high while waiting for a character from the terminal.

Verify that the lower 8 bits of the address are being latched by the 74HCT373.

Verify that the ROM output of the address-decode logic (pin 15 of the 74HCT139) toggles low during the PSEN pulse.

Verify that the RS-232 signals are inverted as they are passed through the MAX233 (see the schematic for pins) and that the RS-232 levels on the 25-pin connector are correct.

Analog Section

If the board establishes communication with the terminal but fails to make conversions, check the following:

If the system hangs when you command it to do a conversion, check pin 23 of the MAX190 to be sure it is receiving its divided-down clock.

If the MAX190 is driven with a known input but the output value is not quite correct, check the voltages on the MAX190's pins for VDD = +5V, VSS = -5V, and DGND = 0V.

If the output value never changes, be sure the MAX190's SDATA line is connected. Also check that AIN+ and AIN- are not shorted together.

If the output value goes from 0 to full scale with an input change of 0V to 10mV, check that VREF is approximately 4.1V. If it is not, check that the EXT REF jumper is not in place and that the EXT REF pin 5 is 0V.

Verify that the data-bus buffer (the 74HCT245) is gated by the A2D-SEL and RD signals.

If the input voltage is not current limited to less than 10mA and exceeds either supply rail, the input structure might be damaged.

The MAX667 will be the warmest IC; all other parts should be at room temperature. If any part gets hot, turn the power off, let the board cool, and recheck. If still hot, check for shorts and replace the IC.

When in BIP mode, AIN- must be offset by 2.5V to allow a -2.048V input. Without the offset, only about -200mV will be output.

MAX190 Evaluation Kit

MAX190 EV KIT

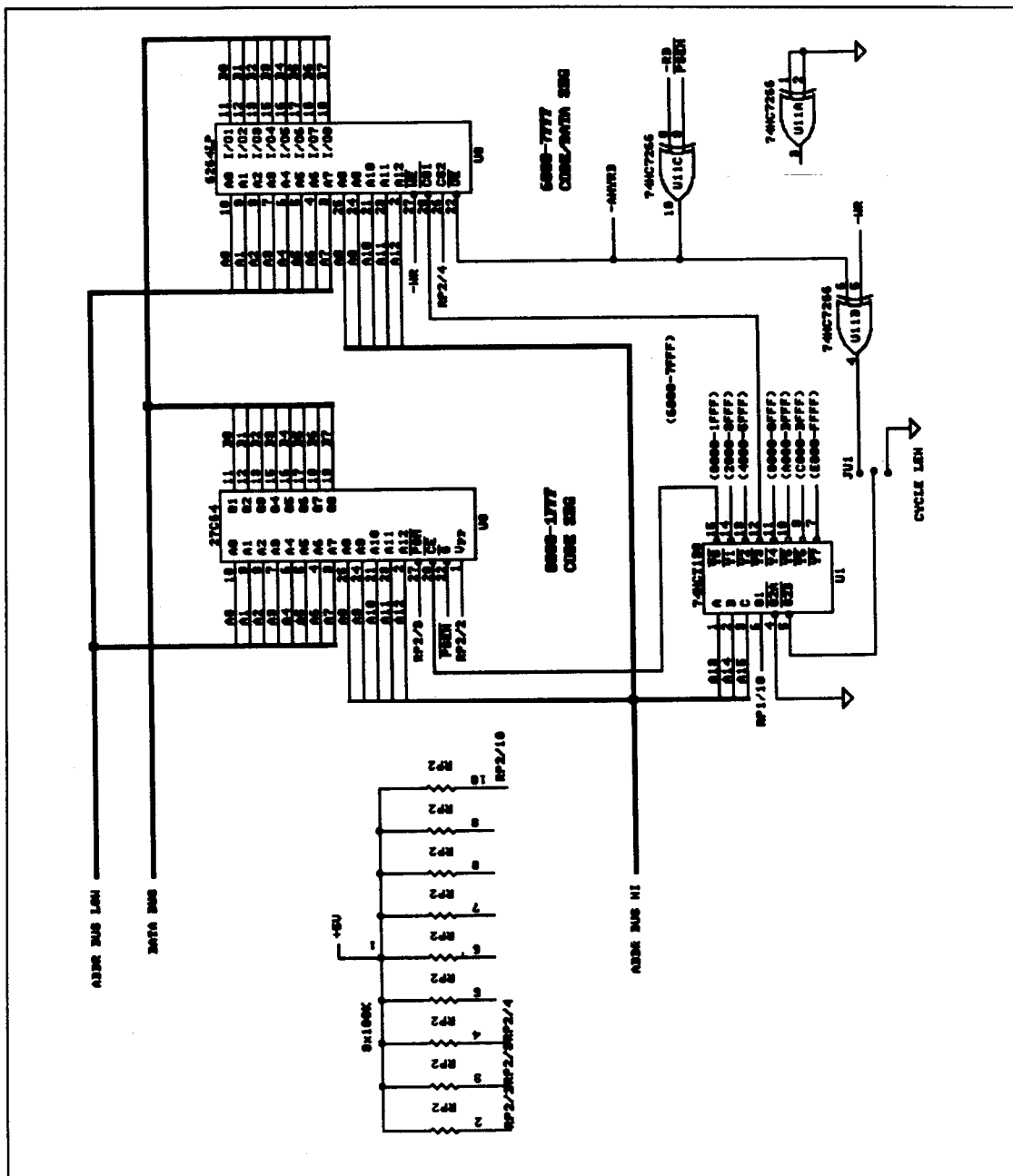

Figure 2b. MAX190 System Schematic

MAX190 EV Kit

MAX190 Evaluation Kit

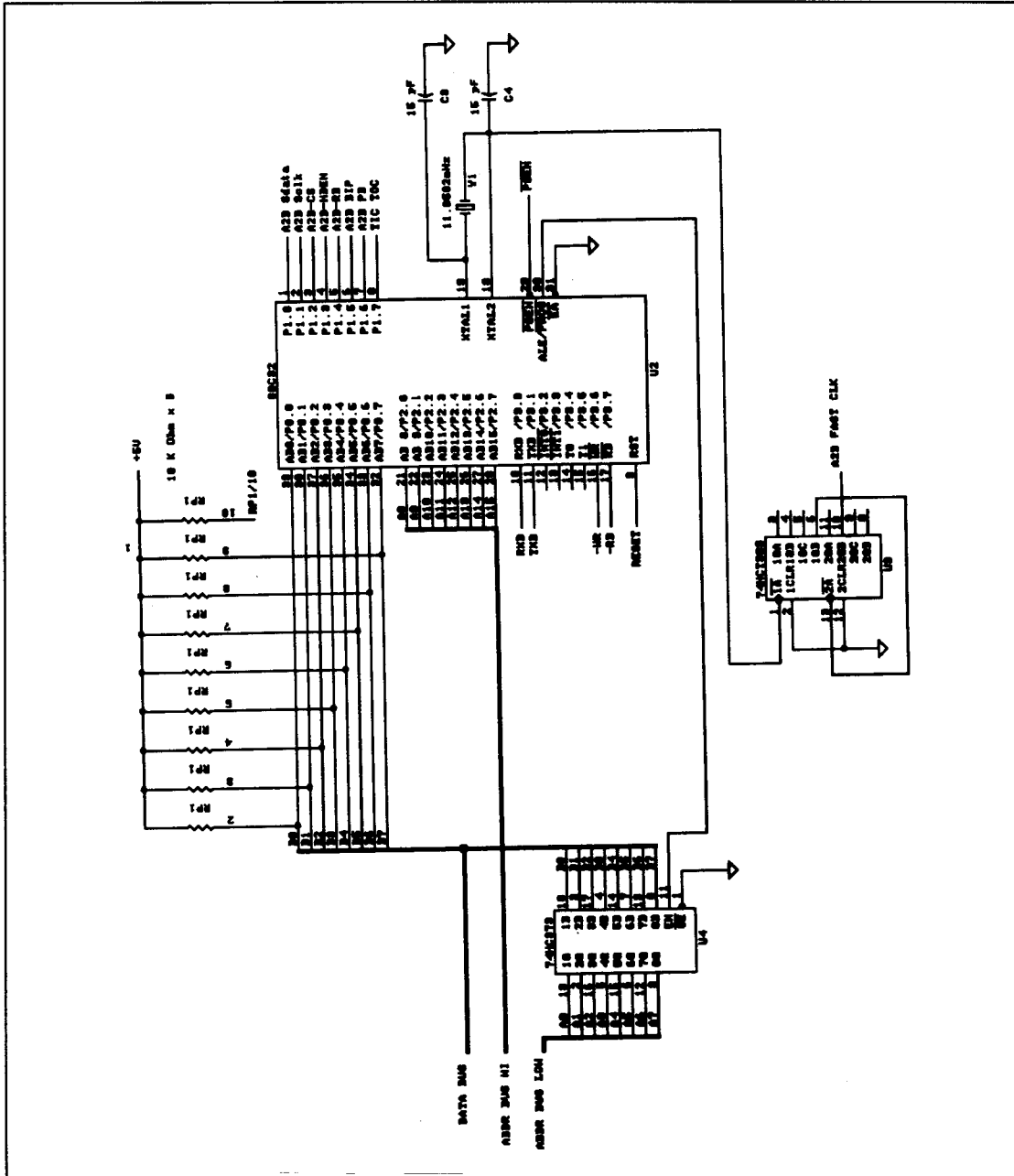

Figure 2c. MAX190 System Schematic

MAX190 Evaluation Kit

MAX190 EV Kit

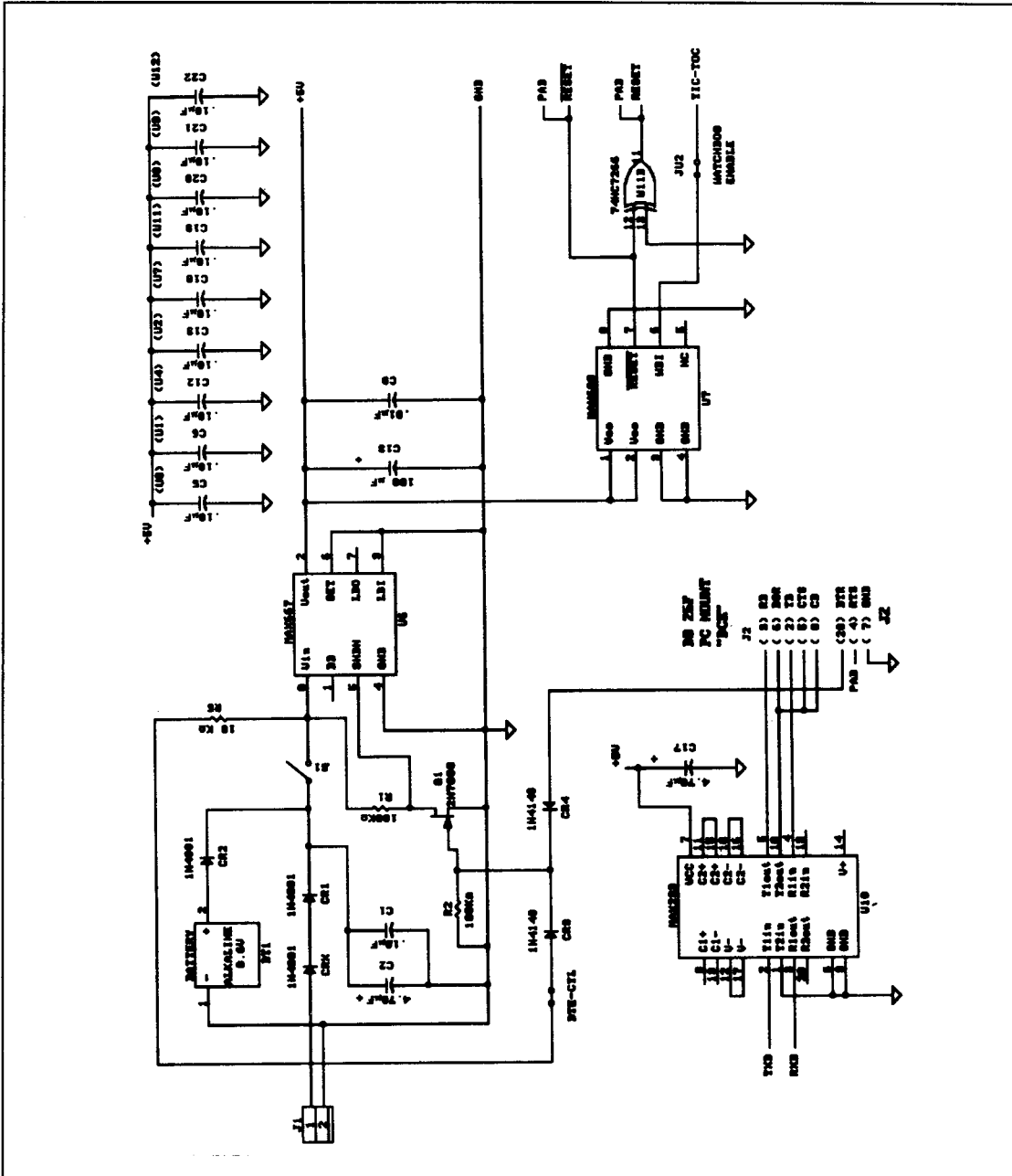

Figure 2d. MAX190 System Schematic

MAX190 EV Kit

MAX190 Evaluation Kit

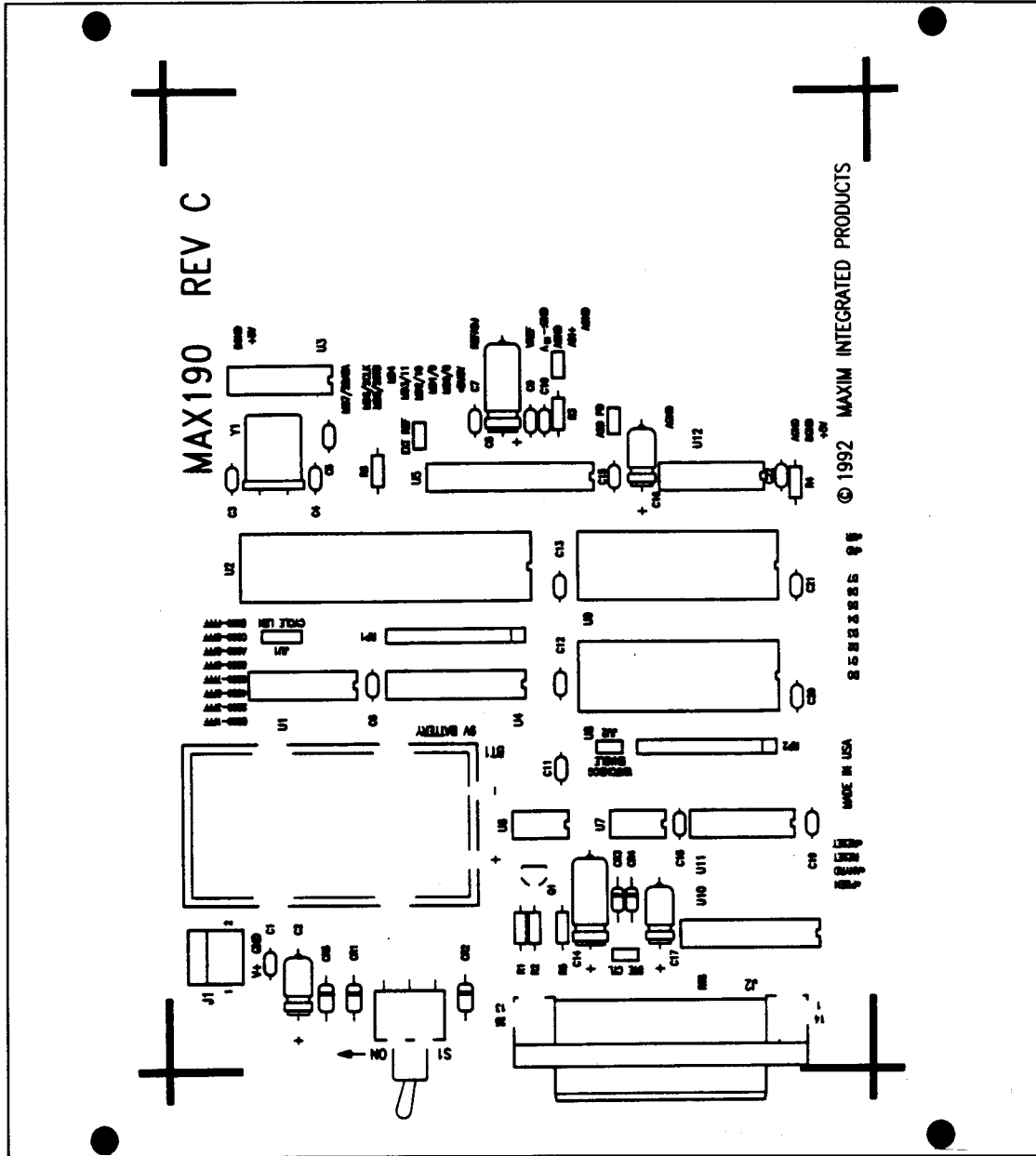

Figure 3. MAX190 Demo Board

Maxim cannot assume responsibility for use of any circuitry other than circuitry entirely embodied in a Maxim product. No circuit patent licenses are implied. Maxim reserves the right to change the circuitry and specifications without notice at any time.

16 Maxim Integrated Products, 120 San Gabriel Drive, Sunnyvale, CA 94086 (408) 737-7600

© 1992 Maxim Integrated Products Printed USA **MAXIM** is a registered trademark of Maxim Integrated Products.