

COMMON DIMENSIONS	
A	0.64±0.05
A1	0.24±0.03
A2	0.43 REF
A3	0.025 BASIC
b	∅0.31±0.03
D1	2.00
E1	2.00
e	0.50 BASIC
SD	0.00 BASIC
SE	0.00 BASIC

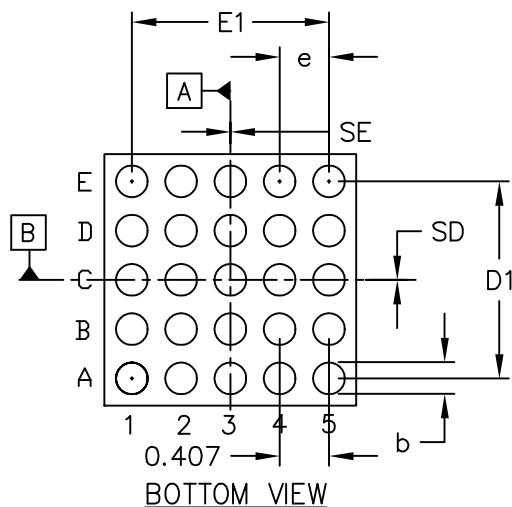

PKG. CODE	E		D		DEPOPULATED BUMPS
	MIN	MAX	MIN	MAX	
W252A2+1	2.47	2.60	2.47	2.60	NONE
W252E2+1	2.69	2.82	2.69	2.82	NONE

NOTES:

1. Terminal pitch is defined by terminal center to center value.
2. Outer dimension is defined by center lines between scribe lines.
3. All dimensions in millimeters.
4. Marking shown is for package orientation reference only.
5. Tolerance is ± 0.02mm unless specified otherwise.
6. All dimensions apply to PbFree (+) package codes only.
7. Front-side finish can be either Black or Clear.

-DRAWING NOT TO SCALE-



TITLE:  
PACKAGE OUTLINE  
25 BUMPS WLP PKG. 0.5mm PITCH

APPROVAL TIE WANG 10/09/09	DOCUMENT CONTROL NO. 21-0191	REV. C	1/1
----------------------------------	---------------------------------	-----------	-----