

1.0625Gbps至10.32Gbps、完全集成的 低功耗SFP+限幅放大器和VCSEL驱动器

概述

MAX3798为高度集成的限幅放大器和VCSEL驱动器，设计用于数据传输速率高达8.5Gbps的1x/2x/4x/8x光纤通道传输系统以及10.3125Gbps数据传输速率的10GBASE-SR传输系统。器件采用+3.3V单电源供电，这款低功耗、集成限幅放大器和VCSEL驱动器IC为SFP MSA以及基于SFP+ MSA的光收发器建立了一个设计平台。高灵敏度限幅放大器将互阻放大器产生的差分输入信号限制在CML电平的差分输出。结构紧凑的VCSEL驱动器为VCSEL二极管提供调制电流和偏置电流。平均光功率由平均功率控制环路(APC)控制，该控制环路通过连接至VCSEL驱动器的3线数字接口控制。所有差分I/O为50Ω传输线PCB设计提供最佳的背板端接。

3线数字接口减少了引脚数量，并可实现高级Rx设置(模式选择、LOS门限、LOS禁止、LOS极性、CML输出电平、信号通道极性、摆率控制、去加重以及快速模式选择转换时间)和Tx设置(调制电流、偏置电流、极性、可编程去加重、眼图交叉点调节以及视觉保护功能)，无需外部元件。MAX3798提供多个电流和电压DAC，允许使用低成本控制器IC。

MAX3798采用无铅、5mm x 5mm、32引脚TQFN封装。

应用

10GBASE-SR SFP+光收发器

1x/2x/4x/8x SFF/SFP/SFP+ MSA 光纤通道(FC)
光收发器

10GBASE-LR SFP+光收发器(1310nm VCSEL)

10GBASE-LRM SFP+光收发器(1310nm VCSEL)

特性

- ◆ 3.3V供电时，功耗仅为320mW
- ◆ 工作速率高达10.32Gbps (NRZ)
- ◆ 10.32Gbps下，具有3mV_{P-P}接收灵敏度
- ◆ 8.5Gbps 8B/10B下接收器输出具有4ps_{P-P} DJ
- ◆ 10.32Gbps 2³¹-1 PRBS下接收器输出具有4ps_{P-P} DJ
- ◆ Rx/Tx具有26ps上升及下降时间
- ◆ 模式选择：高增益模式和宽带模式
- ◆ 高增益模式下提供CML输出摆率调节
- ◆ CML输出，可连续调节电平
- ◆ CML输出禁止
- ◆ Rx和Tx极性选择
- ◆ 可调节触发LOS报警电平
- ◆ LOS极性选择
- ◆ 能够向100Ω差分负载提供高达12mA的调制电流
- ◆ 偏置电流高达15mA
- ◆ 集成视觉保护功能
- ◆ Rx输出可选择去加重
- ◆ 3线数字接口
- ◆ 可调节调制输出的眼图交叉点
- ◆ Tx输出可编程去加重
- ◆ 10μs快速模式选择时间

订购信息

| PART | TEMP RANGE | PIN-PACKAGE |
|-------------|----------------|-------------|
| MAX3798ETJ+ | -40°C to +85°C | 32 TQFN-EP* |

+表示无铅/符合RoHS标准的封装。

*EP = 裸焊盘。

典型应用电路和引脚配置在数据资料的最后给出。

1.0625Gbps至10.32Gbps、完全集成的 低功耗SFP+限幅放大器和VCSEL驱动器

ABSOLUTE MAXIMUM RATINGS

| | | | |
|---|--|--|-----------------|
| V _{CCR} , V _{CC} T, V _{CC} D..... | -0.3V to +4.0V | Current Range into FAULT, LOS..... | -1mA to +5mA |
| Voltage Range at DISABLE, SDA, SCL, CSEL, MSEL, FAULT, BMON, LOS, BMAX, MMAX, CAZ2..... | -0.3V to (V _{CC} + 0.3V) | Current Range into SDA..... | -1mA to +1mA |
| Voltage Range at ROUT+, ROUT- | (V _{CC} - 1V) to (V _{CC} + 0.3V) | Current into ROUT+, ROUT- | 40mA |
| Voltage at TIN+, TIN-..... | (V _{CC} - 2.5V) to (V _{CC} - 0.5V) | Current into TOUT+, TOUT- | 60mA |
| Voltage Range at TOUT+, TOUT- | (V _{CC} - 2V) to (V _{CC} + 0.3V) | Continuous Power Dissipation (T _A = +70°C) 32-Pin TQFN (derate 34.5W/°C above +70°C) | 2759mW |
| Voltage at BIAS..... | 0 to V _{CC} | Operating Junction Temperature Range..... | -55°C to +150°C |
| Voltage at RIN+, RIN-..... | (V _{CC} - 2V) to (V _{CC} - 0.2V) | Storage Temperature Range | -65°C to +160°C |

Stresses beyond those listed under "Absolute Maximum Ratings" may cause permanent damage to the device. These are stress ratings only, and functional operation of the device at these or any other conditions beyond those indicated in the operational sections of the specifications is not implied. Exposure to absolute maximum rating conditions for extended periods may affect device reliability.

ELECTRICAL CHARACTERISTICS

(V_{CC} = 2.85V to 3.63V, T_A = -40°C to +85°C, CML receiver output load is AC-coupled to differential 100Ω, C_{AZ} = 1nF, transmitter output load is AC-coupled to differential 100Ω (see Figure 1), typical values are at +25°C, V_{CC} = 3.3V, I_{BIAS} = 6mA, I_{MOD} = 6mA, unless otherwise specified. Registers are set to default values unless otherwise noted, and the 3-wire interface is static during measurements. For testing, the MODE_SEL bit was used and the MSEL pin was left open.)

| PARAMETER | SYMBOL | CONDITIONS | MIN | TYP | MAX | UNITS |
|--|----------------------|---|--------|---------|--------|-------------------|
| POWER SUPPLY | | | | | | |
| Power-Supply Current | I _{CC} | Includes the CML output current; excludes I _{BIAS} = 6mA, I _{MOD} = 6mA, V _{DIFF_ROUT} = 400mV _{P-P} (Note 1) | | 97 | 150 | mA |
| Power-Supply Voltage | V _{CC} | | 2.85 | | 3.63 | V |
| GENERAL | | | | | | |
| Input Data Rate | | | 1.0625 | | 10.32 | Gbps |
| Input/Output SNR | | | 14.1 | | | |
| BER | | | | | 10E-12 | |
| POWER-ON RESET | | | | | | |
| High POR Threshold | | | | 2.55 | 2.75 | V |
| Low POR Threshold | | I _{BIAS} = I _{BIASOFF} and I _{MOD} = I _{MODOFF} | 2.3 | 2.45 | | V |
| Rx INPUT SPECIFICATIONS | | | | | | |
| Differential Input Resistance RIN+/RIN- | R _{IN_DIFF} | | 75 | 100 | 125 | Ω |
| Input Sensitivity (Note 2) | V _{INMIN} | MODE_SEL = 0 at 4.25Gbps MODE_SEL = 1 at 8.5Gbps | | 2 3 | 4 8 | mV _{P-P} |
| Input Overload | V _{INMAX} | | 1.2 | | | V _{P-P} |
| Input Return Loss | SDD11 | DUT is powered on, f ≤ 5GHz DUT is powered on, f ≤ 16GHz | | 14 7 | | dB |
| Input Return Loss | SCC11 | DUT is powered on, 1GHz < f ≤ 5GHz DUT is powered on, 1GHz < f ≤ 16GHz | | 8 8 | | dB |
| Rx OUTPUT SPECIFICATIONS | | | | | | |
| Differential Output Resistance | R _{OUTDIFF} | | 75 | 100 | 125 | Ω |
| Output Return Loss | SDD22 | DUT is powered on, f ≤ 5GHz DUT is powered on, f ≤ 16GHz | | 11 5 | | dB |

1.0625Gbps至10.32Gbps、完全集成的 低功耗SFP+限幅放大器和VCSEL驱动器

MAX3798

ELECTRICAL CHARACTERISTICS (continued)

($V_{CC} = 2.85V$ to $3.63V$, $T_A = -40^{\circ}C$ to $+85^{\circ}C$, CML receiver output load is AC-coupled to differential 100Ω , $C_{AZ} = 1nF$, transmitter output load is AC-coupled to differential 100Ω (see Figure 1), typical values are at $+25^{\circ}C$, $V_{CC} = 3.3V$, $I_{BIAS} = 6mA$, $I_{MOD} = 6mA$, unless otherwise specified. Registers are set to default values unless otherwise noted, and the 3-wire interface is static during measurements. For testing, the MODE_SEL bit was used and the MSEL pin was left open.)

| PARAMETER | SYMBOL | CONDITIONS | MIN | TYP | MAX | UNITS |
|--|-----------|--|-----------|-----|------|-------------------|
| Output Return Loss | SCC22 | DUT is powered on, $1GHz < f \leq 5GHz$ | 9 | | | dB |
| | | DUT is powered on, $1GHz < f \leq 16GHz$ | 7 | | | |
| CML Differential Output Voltage High | | $5mV_{P-P} \leq V_{IN} \leq 1200mV_{P-P}$, SET_CML[162] | 595 | 800 | 1005 | mV _{P-P} |
| CML Differential Output Voltage Medium | | $10mV_{P-P} \leq V_{IN} \leq 1200mV_{P-P}$, SET_CML[80] | 300 | 400 | 515 | mV _{P-P} |
| Differential Output Signal When Disabled | | Outputs AC-coupled, V_{INMAX} applied to input $V_{DIFF_ROUT} = 800mV_{P-P}$ at 8.5Gbps (Notes 2, 3) | 6 15 | | | mV _{P-P} |
| Data Output Transition Time (20% to 80%) (Notes 2, 3, 4) | t_R/t_F | $10mV_{P-P} \leq V_{IN} \leq 1200mV_{P-P}$, MODE_SEL = 1, $V_{DIFF_ROUT} = 400mV_{P-P}$ | 26 35 | | | ps |
| | | $5mV_{P-P} \leq V_{IN} \leq 1200mV_{P-P}$, MODE_SEL = 0, SLEW_RATE = 1, $V_{DIFF_ROUT} = 800mV_{P-P}$ | 28 50 | | | |
| | | $5mV_{P-P} \leq V_{IN} \leq 1200mV_{P-P}$, MODE_SEL = 0, SLEW_RATE = 0, $V_{DIFF_ROUT} = 800mV_{P-P}$ | 45 | | | |
| Rx TRANSFER CHARACTERISTICS | | | | | | |
| Deterministic Jitter (Notes 2, 3, 5) | DJ | $60mV_{P-P} \leq V_{IN} \leq 400mV_{P-P}$ at 10.32Gbps, MODE_SEL = 1, $V_{DIFF_ROUT} = 400mV_{P-P}$ | 4 12 | | | ps _{P-P} |
| | | $10mV_{P-P} \leq V_{IN} \leq 1200mV_{P-P}$ at 8.5Gbps, MODE_SEL = 1, $V_{DIFF_ROUT} = 400mV_{P-P}$ | 4 12 | | | |
| | | $10mV_{P-P} \leq V_{IN} \leq 1200mV_{P-P}$ at 4.25Gbps, MODE_SEL = 1, $V_{DIFF_ROUT} = 400mV_{P-P}$ | 5 | | | |
| | | $10mV_{P-P} \leq V_{IN} \leq 1200mV_{P-P}$ at 8.5Gbps, MODE_SEL = 0, $V_{DIFF_ROUT} = 400mV_{P-P}$ | 5 10 | | | |
| | | $5mV_{P-P} \leq V_{IN} \leq 1200mV_{P-P}$ at 4.25Gbps, MODE_SEL = 0, SLEW_RATE = 1, $V_{DIFF_ROUT} = 800mV_{P-P}$ | 6 20 | | | |
| | | $5mV_{P-P} \leq V_{IN} \leq 1200mV_{P-P}$ at 4.25Gbps, MODE_SEL = 0, SLEW_RATE = 0, $V_{DIFF_ROUT} = 800mV_{P-P}$ | 7 | | | |
| Random Jitter (Notes 2, 3) | RJ | Input = $60mV_{P-P}$ at 4.25Gbps, MODE_SEL = 0, $V_{DIFF_ROUT} = 800mV_{P-P}$ | 0.36 0.51 | | | ps _{RMS} |
| | | Input = $60mV_{P-P}$ at 8.5Gbps, MODE_SEL = 1, $V_{DIFF_ROUT} = 400mV_{P-P}$ | 0.32 0.48 | | | |
| Low-Frequency Cutoff | | $C_{AZ} = 0.1\mu F$ | 2 | | | kHz |
| | | $C_{AZ} = open$ | 500 | | | |
| Rx LOS SPECIFICATIONS | | | | | | |
| LOS Assert Sensitivity Range | | | 14 | 77 | | mV _{P-P} |
| LOS Hysteresis | | $10 \times \log(V_{DEASSERT}/V_{ASSERT})$ (Note 6) | 1.25 | 2.1 | | dB |

1.0625Gbps至10.32Gbps、完全集成的 低功耗SFP+限幅放大器和VCSEL驱动器

ELECTRICAL CHARACTERISTICS (continued)

($V_{CC} = 2.85V$ to $3.63V$, $T_A = -40^{\circ}C$ to $+85^{\circ}C$, CML receiver output load is AC-coupled to differential 100Ω , $C_{AZ} = 1nF$, transmitter output load is AC-coupled to differential 100Ω (see Figure 1), typical values are at $+25^{\circ}C$, $V_{CC} = 3.3V$, $I_{BIAS} = 6mA$, $I_{MOD} = 6mA$, unless otherwise specified. Registers are set to default values unless otherwise noted, and the 3-wire interface is static during measurements. For testing, the MODE_SEL bit was used and the MSEL pin was left open.)

| PARAMETER | SYMBOL | CONDITIONS | MIN | TYP | MAX | UNITS |
|--|--------------|--|-------|------|-----|-------------------|
| LOS Assert/Deassert Time | | (Note 7) | 2.3 | | 80 | μs |
| Low Assert Level | | SET_LOS[7] (Notes 2, 6) | 8 | 11 | 14 | mV _{P-P} |
| Low Deassert Level | | SET_LOS[7] (Notes 2, 6) | 14 | 18 | 21 | mV _{P-P} |
| Medium Assert Level | | SET_LOS[32] (Notes 2, 6) | 39 | 48 | 58 | mV _{P-P} |
| Medium Deassert Level | | SET_LOS[32] (Notes 2, 6) | 65 | 81 | 95 | mV _{P-P} |
| High Assert Level | | SET_LOS[63] (Notes 2, 6) | 77 | 94 | 112 | mV _{P-P} |
| High Deassert Level | | SET_LOS[63] (Notes 2, 6) | 127 | 158 | 182 | mV _{P-P} |
| Tx INPUT SPECIFICATIONS | | | | | | |
| Differential Input Voltage | V_{IN} | Data rate = 1.0625Gbps to 4.25Gbps | 0.2 | | 2.4 | V _{P-P} |
| | | Data rate = 4.25Gbps to 10.32Gbps | 0.075 | | 0.8 | |
| Common-Mode Input Voltage | V_{INCM} | | | 2.75 | | V |
| Differential Input Resistance | R_{IN} | | 75 | 100 | 125 | Ω |
| Input Return Loss | SDD11 | DUT is powered on, $f \leq 5GHz$ | | 15 | | dB |
| | | DUT is powered on, $f \leq 16GHz$ | | 6 | | |
| Input Return Loss | SCC11 | DUT is powered on, $1GHz < f \leq 5GHz$ | | 9 | | dB |
| | | DUT is powered on, $1GHz < f \leq 16GHz$ | | 5 | | |
| Tx LASER MODULATOR | | | | | | |
| Maximum Modulation-On Current into 100Ω Differential Load | I_{MODMAX} | Outputs AC-coupled, $V_{CCTO} \geq 2.95V$ | 12 | | | mA |
| Minimum Modulation-On Current into 100Ω Differential Load | I_{MODMIN} | Outputs AC-coupled | | | 2 | mA |
| Modulation Current DAC Stability | | $2mA \leq I_{MOD} \leq 12mA$ (Note 8) | | | 4 | % |
| Modulation Current Rise Time/Fall Time | t_r/t_f | $5mA \leq I_{MOD} \leq 10mA$, 20% to 80%, SET_TXDE[3:0] = 10 (Notes 2, 4) | | 26 | 39 | ps |
| Deterministic Jitter (Notes 2, 9) | DJ | $5mA \leq I_{MOD} \leq 12mA$, at 10.32Gbps, $250mV_{P-P} \leq V_{IN} \leq 800mV_{P-P}$, SET_TXDE[3:0] = 0 | | 6 | 12 | ps |
| | | $5mA \leq I_{MOD} \leq 12mA$, at 10.32Gbps, $250mV_{P-P} \leq V_{IN} \leq 800mV_{P-P}$, SET_TXDE[3:0] = 10 | | 6 | 13 | |
| | | $5mA \leq I_{MOD} \leq 12mA$, at 8.5Gbps, $250mV_{P-P} \leq V_{IN} \leq 800mV_{P-P}$, SET_TXDE[3:0] = 0 | | 6 | 12 | |
| | | $5mA \leq I_{MOD} \leq 12mA$, at 8.5Gbps, $250mV_{P-P} \leq V_{IN} \leq 800mV_{P-P}$, SET_TXDE[3:0] = 10 | | 6 | 12 | |
| | | $2mA \leq I_{MOD} \leq 12mA$, at 4.25Gbps | | 5 | | |
| | | $2mA \leq I_{MOD} \leq 12mA$, at 1.0625Gbps | | 5 | | |

1.0625Gbps至10.32Gbps、完全集成的 低功耗SFP+限幅放大器和VCSEL驱动器

MAX3798

ELECTRICAL CHARACTERISTICS (continued)

($V_{CC} = 2.85V$ to $3.63V$, $T_A = -40^{\circ}C$ to $+85^{\circ}C$, CML receiver output load is AC-coupled to differential 100Ω , $C_{AZ} = 1nF$, transmitter output load is AC-coupled to differential 100Ω (see Figure 1), typical values are at $+25^{\circ}C$, $V_{CC} = 3.3V$, $I_{BIAS} = 6mA$, $I_{MOD} = 6mA$, unless otherwise specified. Registers are set to default values unless otherwise noted, and the 3-wire interface is static during measurements. For testing, the MODE_SEL bit was used and the MSEL pin was left open.)

| PARAMETER | SYMBOL | CONDITIONS | MIN | TYP | MAX | UNITS |
|---|---------------|---|------------------|-----------------|------------------|---------------|
| Random Jitter | | $5mA \leq I_{MOD} \leq 12mA$, $250mV_{P-P} \leq V_{IN} \leq 800mV_{P-P}$ | | 0.17 | 0.5 | μs_{RMS} |
| Output Return Loss | SDD22 | DUT is powered on, $f \leq 5GHz$ | | 12 | | dB |
| | | DUT is powered on, $f \leq 16GHz$ | | 5 | | |
| Tx BIAS GENERATOR | | | | | | |
| Maximum Bias-On Current | $I_{BIASMAX}$ | Current into BIAS pin | 15 | | | mA |
| Minimum Bias-On Current | $I_{BIASMIN}$ | Current into BIAS pin | | | 2 | mA |
| BIAS Current DAC Stability | | $2mA \leq I_{BIAS} \leq 15mA$ (Notes 2, 10) | | | 4 | % |
| Compliance Voltage at BIAS | V_{BIAS} | | 0.9 | | 2.1 | V |
| BIAS Current Monitor Current Gain | I_{BMON} | External resistor to GND defines the voltage gain | | 16 | | mA/A |
| Compliance Voltage at BMON | V_{BMON} | | 0 | | 1.8 | V |
| BIAS Current Monitor Current Gain Stability | I_{BMON} | $2mA \leq I_{BIAS} \leq 15mA$ (Note 10) | | | 5 | % |
| Tx SAFETY FEATURES | | | | | | |
| Excessive Voltage at BMAX | V_{BMAX} | Average voltage, FAULT always occurs for $V_{BMAX} \leq V_{CC} - 0.65V$, FAULT never occurs for $V_{BMAX} \geq V_{CC} - 0.55V$ | $V_{CC} - 0.65V$ | $V_{CC} - 0.6V$ | $V_{CC} - 0.55V$ | V |
| Excessive Voltage at MMAX | V_{MMAX} | Average voltage, FAULT always occurs for $V_{MMAX} \leq V_{CC} - 0.65V$, FAULT never occurs for $V_{MMAX} \geq V_{CC} - 0.55V$ | $V_{CC} - 0.65V$ | $V_{CC} - 0.6V$ | $V_{CC} - 0.55V$ | V |
| Excessive Voltage at BMON | V_{BMON} | Average voltage, FAULT warning always occurs for $V_{BMON} \geq V_{CC} - 0.55V$, FAULT warning never occurs for $V_{BMON} \leq V_{CC} - 0.65V$ | $V_{CC} - 0.65V$ | $V_{CC} - 0.6V$ | $V_{CC} - 0.55V$ | V |
| Excessive Voltage at BIAS | V_{BIAS} | Average voltage, FAULT always occurs for $V_{BIAS} \leq 0.44V$, FAULT never occurs for $V_{BIAS} \geq 0.65V$ | 0.44 | 0.48 | 0.65 | V |
| Maximum VCSEL Current in Off State | I_{OFF} | FAULT or DISABLE, $V_{BIAS} = V_{CC}$ | | | 25 | μA |
| SFP TIMING REQUIREMENTS | | | | | | |
| Mode-Select Change Time | $t_{MODESEL}$ | Time from rising or falling edge at MSEL until Rx output PWD falls below 10ps | | 10 | | μs |
| DISABLE Assert Time | t_{OFF} | Time from rising edge of DISABLE input signal to $I_{BIAS} = I_{BIASOFF}$ and $I_{MOD} = I_{MODOFF}$ | | | 1 | μs |

1.0625Gbps至10.32Gbps、完全集成的 低功耗SFP+限幅放大器和VCSEL驱动器

ELECTRICAL CHARACTERISTICS (continued)

($V_{CC} = 2.85V$ to $3.63V$, $T_A = -40^{\circ}C$ to $+85^{\circ}C$, CML receiver output load is AC-coupled to differential 100Ω , $C_{AZ} = 1nF$, transmitter output load is AC-coupled to differential 100Ω (see Figure 1), typical values are at $+25^{\circ}C$, $V_{CC} = 3.3V$, $I_{BIAS} = 6mA$, $I_{MOD} = 6mA$, unless otherwise specified. Registers are set to default values unless otherwise noted, and the 3-wire interface is static during measurements. For testing, the MODE_SEL bit was used and the MSEL pin was left open.)

| PARAMETER | SYMBOL | CONDITIONS | MIN | TYP | MAX | UNITS |
|--|---------------------|--|-----|-----------|----------|-----------|
| DISABLE Negate Time | t_{ON} | Time from falling edge of DISABLE to I_{BIAS} and I_{MOD} at 90% of steady state when FAULT = 0 before reset | | | 500 | μs |
| FAULT Reset Time of Power-On Time | t_{INIT} | Time from power-on or negation of FAULT using DISABLE | | | 100 | ms |
| FAULT Reset Time | t_{FAULT} | Time from fault to FAULT on, $C_{FAULT} \leq 20pF$, $R_{FAULT} = 4.7k\Omega$ | | | 10 | μs |
| DISABLE to Reset | | Time DISABLE must be held high to reset FAULT | 5 | | | μs |
| OUTPUT LEVEL VOLTAGE DAC (SET_CML) | | | | | | |
| Full-Scale Voltage | V_{FS} | 100Ω differential resistive load | | 1200 | | mVp-p |
| Resolution | | | | 5 | | mVp-p |
| Integral Nonlinearity | INL | $5mA \leq I_{CML_LEVEL} \leq 20mA$ | | ± 0.9 | | LSB |
| LOS THRESHOLD VOLTAGE DAC (SET_LOS) | | | | | | |
| Full-Scale Voltage | V_{FS} | | | 94 | | mVp-p |
| Resolution | | | | 1.5 | | mVp-p |
| Integral Nonlinearity | INL | $11mVp-p \leq V_{TH_LOS} \leq 94mVp-p$ | | ± 0.7 | | LSB |
| BIAS CURRENT DAC (SET_IBIAS) | | | | | | |
| Full-Scale Current | I_{FS} | | | 21 | | mA |
| Resolution | | | | 40 | | μA |
| Integral Nonlinearity | INL | $1mA \leq I_{BIAS} \leq 15mA$ | | ± 1 | | LSB |
| Differential Nonlinearity | DNL | $1mA \leq I_{BIAS} \leq 15mA$, guaranteed monotonic at 8-bit resolution (SET_IBIAS[8:1]) | | ± 1 | | LSB |
| MODULATION CURRENT DAC (SET_IMOD) | | | | | | |
| Full-Scale Current | I_{FS} | | | 21 | | mA |
| Resolution | | | | 40 | | μA |
| Integral Nonlinearity | INL | $2mA \leq I_{MOD} \leq 12mA$ | | ± 1 | | LSB |
| Differential Nonlinearity | DNL | $2mA \leq I_{MOD} \leq 12mA$, guaranteed monotonic at 8-bit resolution (SET_IMOD[8:1]) | | ± 1 | | LSB |
| CONTROL I/O SPECIFICATIONS | | | | | | |
| MSEL Input Current | I_{IH} , I_{IL} | | | | 150 | μA |
| MSEL Input High Voltage | V_{IH} | | 1.8 | | V_{CC} | V |
| MSEL Input Low Voltage | V_{IL} | | 0 | | 0.8 | V |
| MSEL Input Impedance | R_{PULL} | Internal pulldown resistor | 40 | 75 | 110 | $k\Omega$ |
| DISABLE Input Current | I_{IH} | | | | 12 | μA |
| | I_{IL} | Dependency on pullup resistance | | 420 | 800 | |
| DISABLE Input High Voltage | V_{IH} | | 1.8 | | V_{CC} | V |

1.0625Gbps至10.32Gbps、完全集成的 低功耗SFP+限幅放大器和VCSEL驱动器

MAX3798

ELECTRICAL CHARACTERISTICS (continued)

($V_{CC} = 2.85V$ to $3.63V$, $T_A = -40^{\circ}C$ to $+85^{\circ}C$, CML receiver output load is AC-coupled to differential 100Ω , $C_{AZ} = 1nF$, transmitter output load is AC-coupled to differential 100Ω (see Figure 1), typical values are at $+25^{\circ}C$, $V_{CC} = 3.3V$, $I_{BIAS} = 6mA$, $I_{MOD} = 6mA$, unless otherwise specified. Registers are set to default values unless otherwise noted, and the 3-wire interface is static during measurements. For testing, the MODE_SEL bit was used and the MSEL pin was left open.)

| PARAMETER | SYMBOL | CONDITIONS | MIN | TYP | MAX | UNITS |
|---|------------------|--|----------------|-------|----------|-----------|
| DISABLE Input Low Voltage | V_{IL} | | 0 | | 0.8 | V |
| DISABLE Input Impedance | RPULL | Internal pullup resistor | 5.5 | 8 | 10.5 | $k\Omega$ |
| LOS, FAULT Output High Voltage | V_{OH} | $R_{LOS} = 4.7k\Omega - 10k\Omega$ to V_{CC} , $R_{FAULT} = 4.7k\Omega - 10k\Omega$ to V_{CC} | $V_{CC} - 0.5$ | | V_{CC} | V |
| LOS, FAULT Output Low Voltage | V_{OL} | $R_{LOS} = 4.7k\Omega - 10k\Omega$ to V_{CC} , $R_{FAULT} = 4.7k\Omega - 10k\Omega$ to V_{CC} | 0 | | 0.4 | V |
| 3-WIRE DIGITAL I/O SPECIFICATIONS (SDA, CSEL, SCL) | | | | | | |
| Input High Voltage | V_{IH} | | 2.0 | | V_{CC} | V |
| Input Low Voltage | V_{IL} | | | | 0.8 | V |
| Input Hysteresis | V_{HYST} | | | 0.082 | | V |
| Input Leakage Current | I_{IL}, I_{IH} | $V_{IN} = 0V$ or V_{CC} ; internal pullup or pulldown ($75k\Omega$ typical) | | | 150 | μA |
| Output High Voltage | V_{OH} | External pullup of $4.7k\Omega$ to V_{CC} | $V_{CC} - 0.5$ | | | V |
| Output Low Voltage | V_{OL} | External pullup of $4.7k\Omega$ to V_{CC} | | | 0.4 | V |
| 3-WIRE DIGITAL INTERFACE TIMING CHARACTERISTICS (see Figure 4) | | | | | | |
| SCL Clock Frequency | f_{SCL} | | | 400 | 1000 | kHz |
| SCL Pulse-Width High | t_{CH} | | 0.5 | | | μs |
| SCL Pulse-Width Low | t_{CL} | | 0.5 | | | μs |
| SDA Setup Time | t_{DS} | | | 100 | | ns |
| SDA Hold Time | t_{DH} | | | 100 | | ns |
| SCL Rise to SDA Propagation Time | t_D | | | 5 | | ns |
| CSEL Pulse-Width Low | t_{CSW} | | 500 | | | ns |
| CSEL Leading Time Before the First SCL Edge | t_L | | | 500 | | ns |
| CSEL Trailing Time After the Last SCL Edge | t_T | | | 500 | | ns |
| SDA, SCL External Load | C_B | Total bus capacitance on one line with $4.7k\Omega$ pullup to V_{CC} | | | 20 | pF |

Note 1: Supply current is measured with unterminated receiver CML output or with AC-coupled Rx output termination. The Tx output and the bias current output must be connected to a separate supply in order to remove the modulation/bias current portion from the supply current. BIAS must be connected to 2.0V. TOUT+/- must be connected through 50Ω load resistors to a separate supply voltage.

Note 2: Guaranteed by design and characterization, $T_A = -40^{\circ}C$ to $+95^{\circ}C$.

Note 3: The data input transition time is controlled by a 4th-order Bessel filter with -3dB frequency = $0.75 \times$ data rate. The deterministic jitter caused by this filter is not included in the DJ generation specifications.

Note 4: Test pattern is 00001111 at 4.25Gbps for MODE_SEL = 0. Test pattern is 00001111 at 8.5Gbps for MODE_SEL = 1.

1.0625Gbps至10.32Gbps、完全集成的 低功耗SFP+限幅放大器和VCSEL驱动器

Note 5: Receiver deterministic jitter is measured with a repeating $2^{31} - 1$ PRBS equivalent pattern at 10.32Gbps. For 1.0625Gbps to 8.5Gbps, a repeating K28.5 pattern [00111110101100000101] is used. Deterministic jitter is defined as the arithmetic sum of pulse-width distortion (PWD) and pattern-dependent jitter (PDJ).

Note 6: Measured with a k28.5 pattern from 1.0625Gbps to 8.5Gbps. Measured with $2^{31} - 1$ PRBS at 10.32Gbps.

Note 7: Measurement includes an input AC-coupling capacitor of 100nF and C_{CAZ} of 100nF. The signal at the input is switched between two amplitudes: Signal_ON and Signal_OFF.

1) Receiver operates at sensitivity level plus 1dB power penalty.

a) Signal_OFF = 0

Signal_ON = (+8dB) + 10log(min_assert_level)

b) Signal_ON = (+1dB) + 10log(max_deassert_level)

Signal_OFF = 0

2) Receiver operates at overload.

Signal_OFF = 0

Signal_ON = 1.2V_{P-P}

max_deassert_level and the min_assert_level are measured for one LOS_THRESHOLD setting.

Note 8: Gain stability is defined as $[(I_{\text{measured}}) - (I_{\text{reference}})] / (I_{\text{reference}})$ over the listed current range, temperature, and V_{CC} from +2.95V to +3.63V. Reference current measured at $V_{CC} = +3.2V$, $T_A = +25^{\circ}C$.

Note 9: Transmitter deterministic jitter is measured with a repeating $2^7 - 1$ PRBS, 72 0s, $2^7 - 1$ PRBS, and 72 1s pattern at 10.32Gbps. For 1.0625Gbps to 8.5Gbps, a repeating K28.5 pattern [00111110101100000101] is used. Deterministic jitter is defined as the arithmetic sum of PWD and PDJ.

Note 10: Gain stability is defined as $[(I_{\text{measured}}) - (I_{\text{reference}})] / (I_{\text{reference}})$ over the listed current range, temperature, and V_{CC} from +2.85V to +3.63V. Reference current measured at $V_{CC} = +3.3V$, $T_A = +25^{\circ}C$.



图1. VCSEL驱动器特性测试电路

1.0625Gbps至10.32Gbps、完全集成的 低功耗SFP+限幅放大器和VCSEL驱动器

典型工作特性—限幅放大器

($V_{CC} = 3.3V$, $T_A = +25^{\circ}C$, unless otherwise specified. Figure 1 shows the typical setup used for measurements. Registers are set to default values unless otherwise noted, and the 3-wire interface is static during measurements. For testing, the MODE_SEL bit was used and the MSEL pin was left open.)

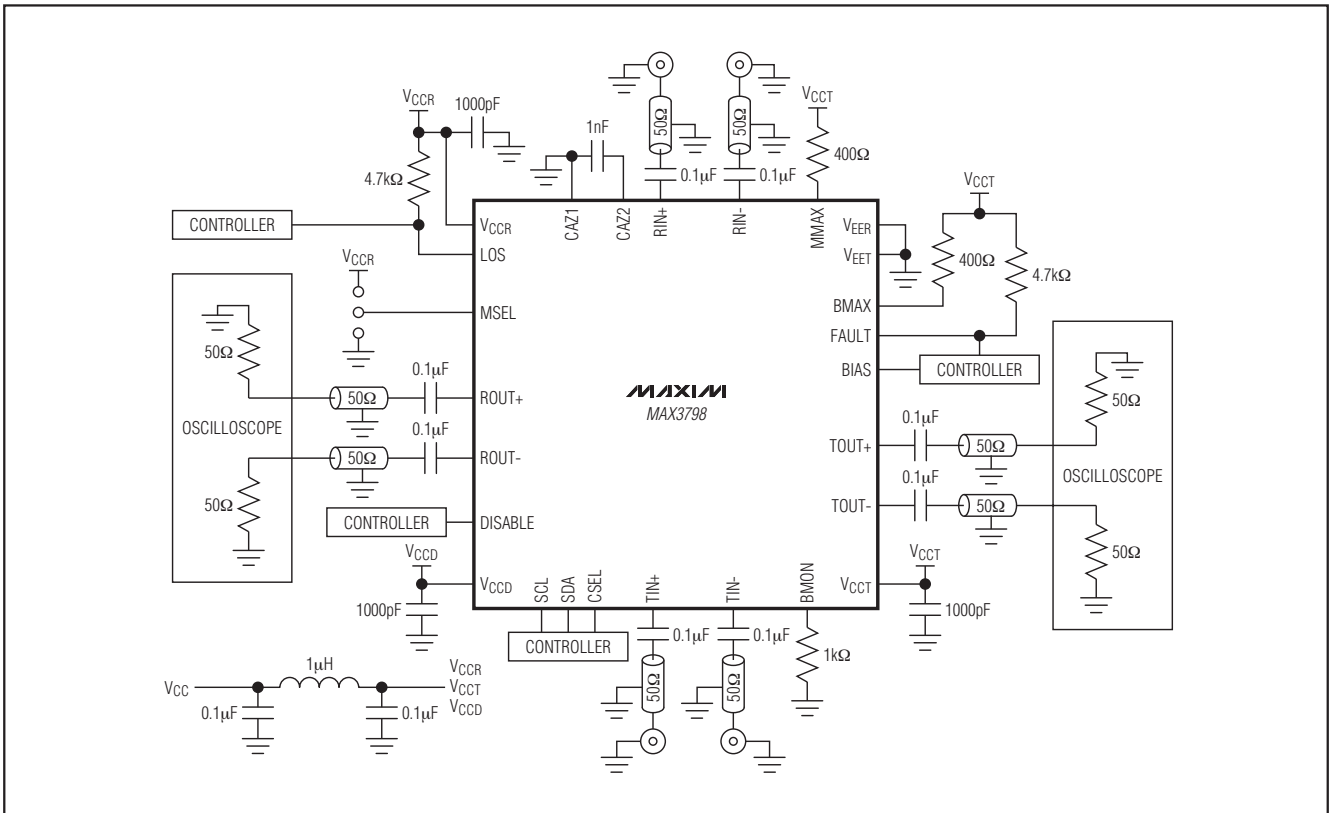
MAX3798

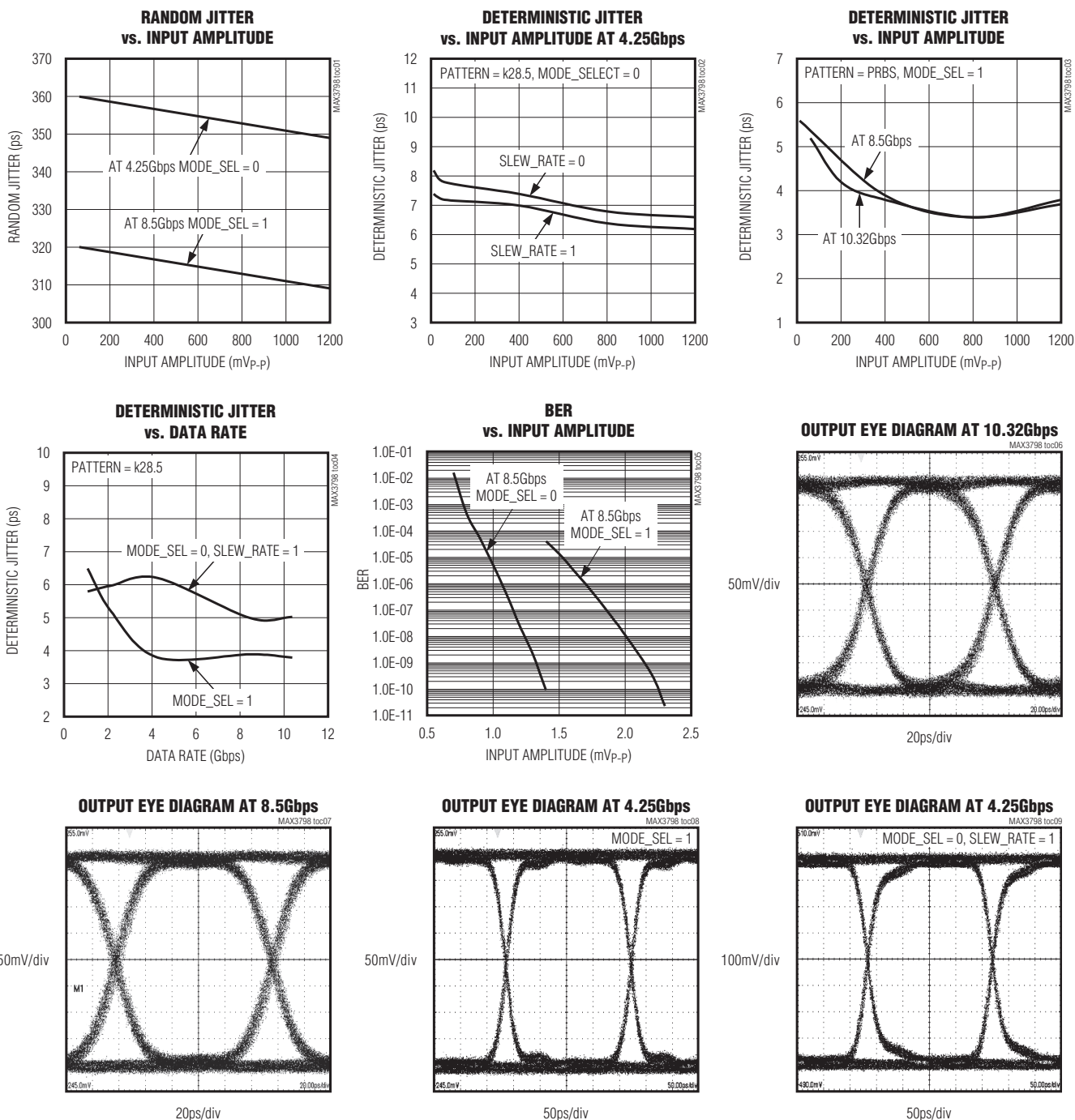

1.0625Gbps至10.32Gbps、完全集成的 低功耗SFP+限幅放大器和VCSEL驱动器

典型工作特性—限幅放大器(续)

($V_{CC} = 3.3V$, $T_A = +25^\circ C$, unless otherwise specified. Figure 1 shows the typical setup used for measurements. Registers are set to default values unless otherwise noted, and the 3-wire interface is static during measurements. For testing, the MODE_SEL bit was used and the MSEL pin was left open.)

OUTPUT EYE DIAGRAM AT 4.25Gbps

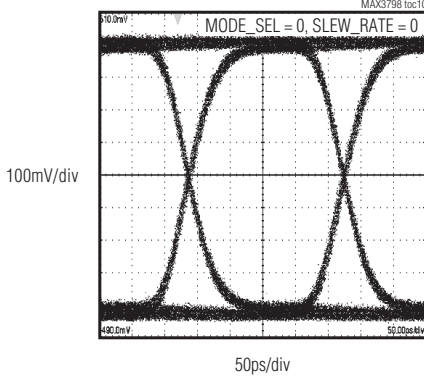

TRANSITION TIME vs. INPUT AMPLITUDE

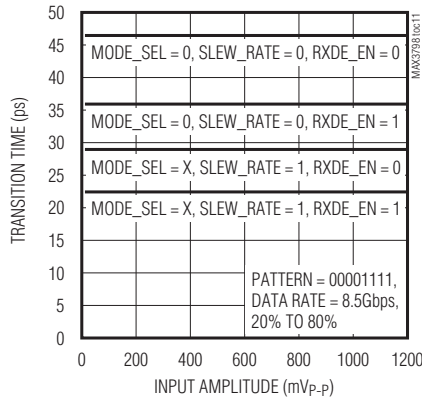

LOS THRESHOLD vs. DAC SETTING

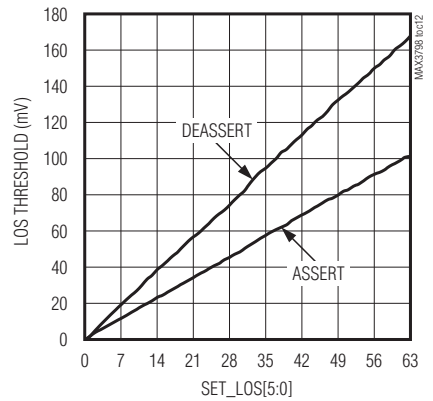

SENSITIVITY vs. DATA RATE

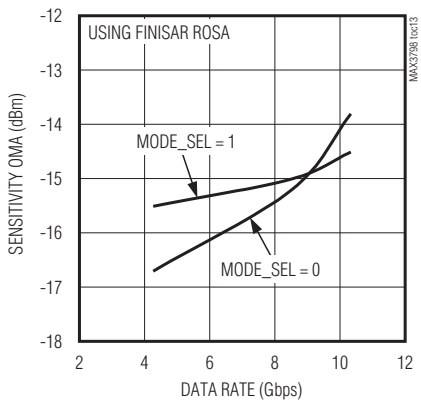

Rx INPUT RETURN LOSS

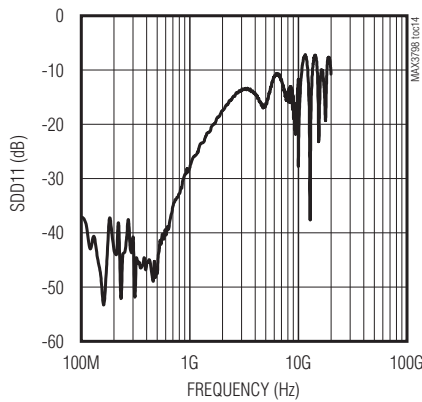

Rx OUTPUT RETURN LOSS

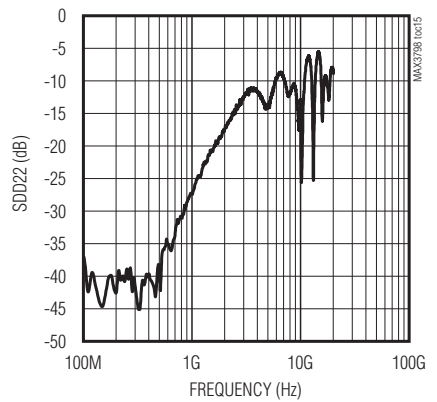

CML OUTPUT AMPLITUDE vs. DAC SETTING

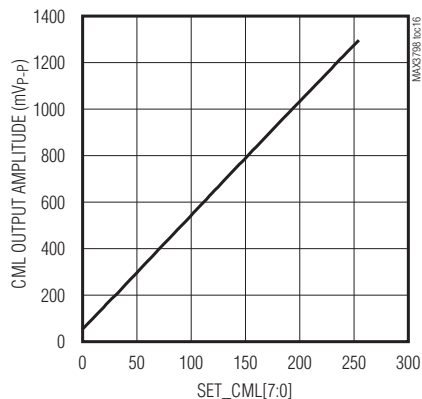

1.0625Gbps至10.32Gbps、完全集成的 低功耗SFP+限幅放大器和VCSEL驱动器

典型工作特性—VCSEL驱动器

($V_{CC} = 3.3V$, $T_A = +25^\circ C$, unless otherwise specified. Figure 1 shows the typical setup used for measurements. Registers are set to default values unless otherwise noted, and the 3-wire interface is static during measurements. For testing, the MODE_SEL bit was used and the MSEL pin was left open.)

MAX3798

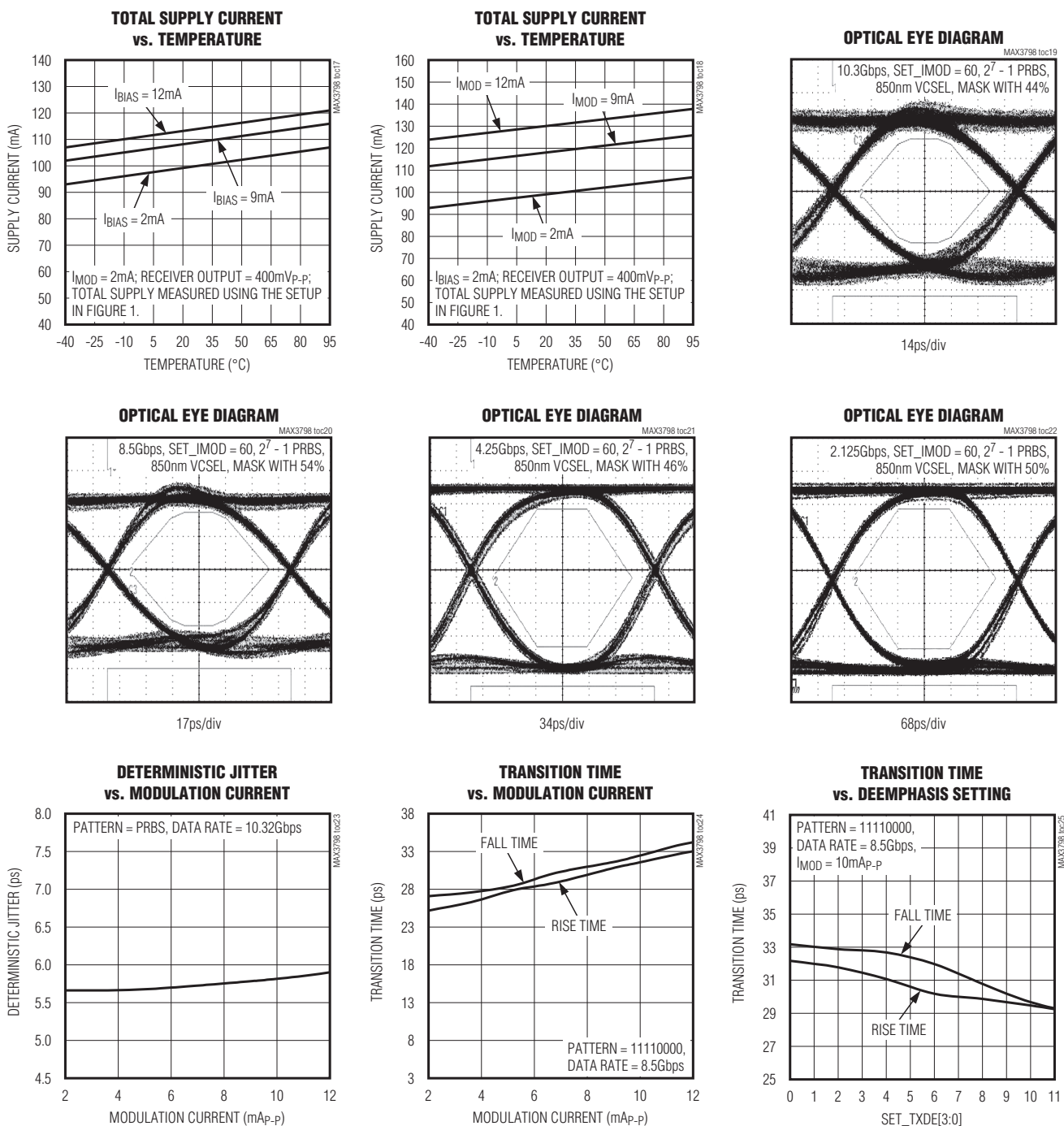

1.0625Gbps至10.32Gbps、完全集成的 低功耗SFP+限幅放大器和VCSEL驱动器

典型工作特性—VCSEL驱动器(续)

($V_{CC} = 3.3V$, $T_A = +25^\circ C$, unless otherwise specified. Figure 1 shows the typical setup used for measurements. Registers are set to default values unless otherwise noted, and the 3-wire interface is static during measurements. For testing, the MODE_SEL bit was used and the MSEL pin was left open.)

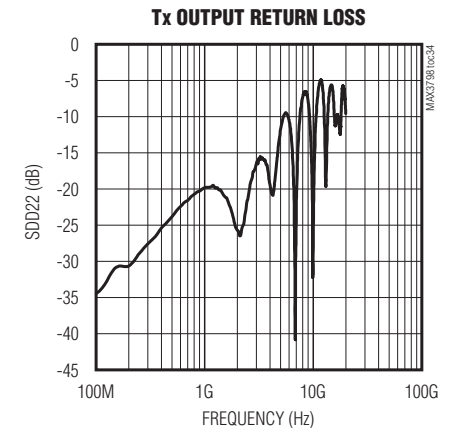
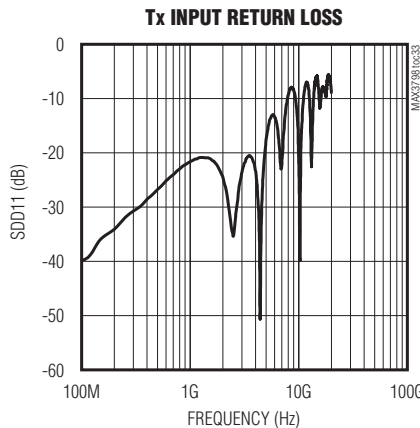
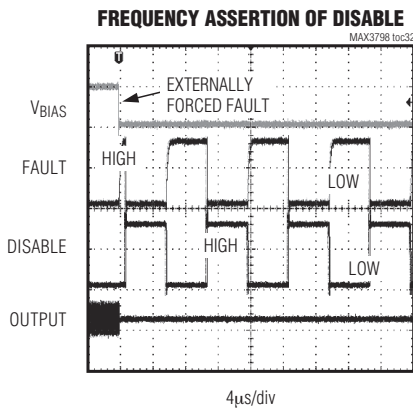
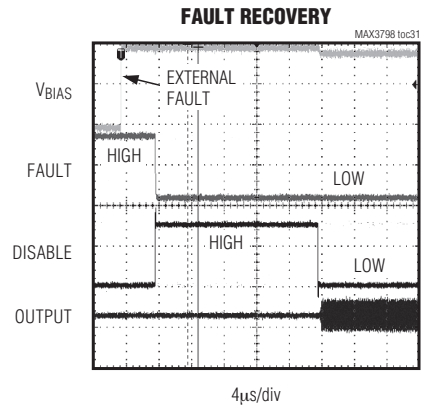
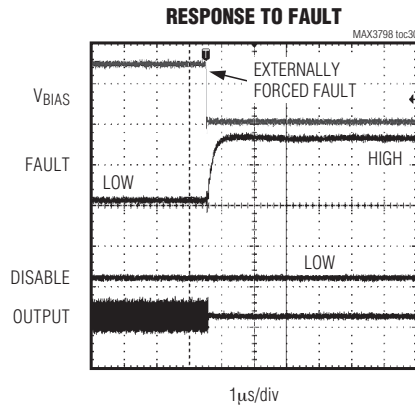
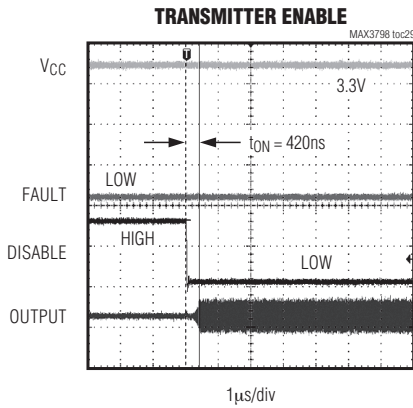
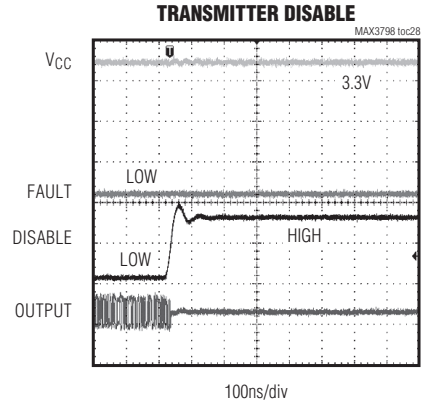
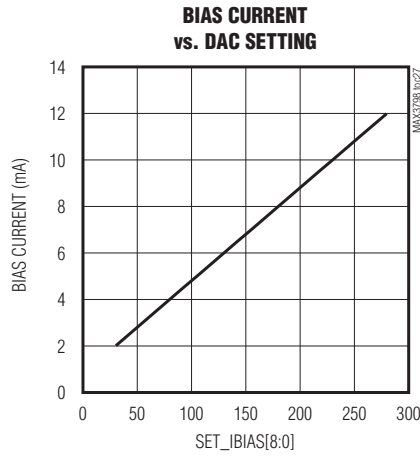
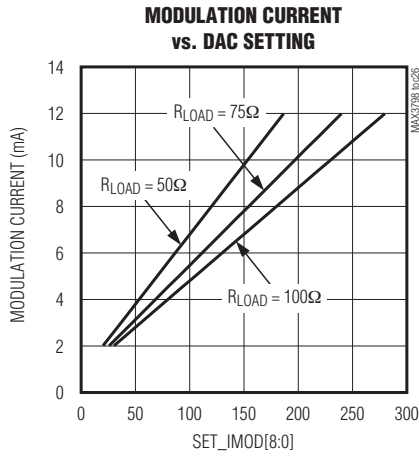

1.0625Gbps至10.32Gbps、完全集成的 低功耗SFP+限幅放大器和VCSEL驱动器

MAX3798

典型工作特性—VCSEL驱动器(续)

($V_{CC} = 3.3V$, $T_A = +25^\circ C$, unless otherwise specified. Figure 1 shows the typical setup used for measurements. Registers are set to default values unless otherwise noted, and the 3-wire interface is static during measurements. For testing, the MODE_SEL bit was used and the MSEL pin was left open.)

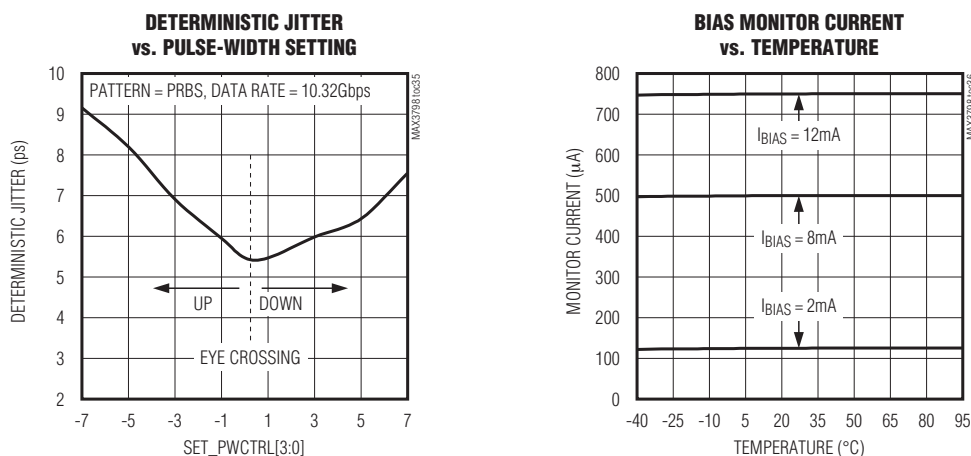

引脚说明

| 引脚 | 名称 | 功能 |
|----------------|------------------|--|
| 1 | LOS | 信号丢失检测输出, 开漏。当输入信号电平低于由SET_LOS DAC预设的门限时, LOS的默认极性为高电平。LOS功能的极性可通过设置LOS_POL = 0反转。通过设置LOS_EN = 0, 即可禁用LOS电路。 |
| 2 | MSEL | 模式选择输入, TTL/CMOS。将MSEL引脚或MODE_SEL位(通过3线数字接口设置)设置为逻辑高电平, 即为宽带模式; 将MSEL和MODE_SEL设置为逻辑低电平, 即为高增益模式。MSEL引脚在内部由一个75k Ω 电阻下拉至地。 |
| 3, 6, 27, 30 | VCCR | 电源, 为接收电路提供供电电压。 |
| 4 | ROUT+ | 同相接收数据输出, CML。50 Ω 负载背板端接。 |
| 5 | ROUT- | 反相接收数据输出, CML。50 Ω 负载背板端接。 |
| 7 | VCCD | 电源, 为数字电路提供供电电压。 |
| 8 | DISABLE | 发送器禁用输入, TTL/CMOS。设置为逻辑低电平时正常工作; 设置为逻辑高电平或开路时禁止产生调制和偏置电流。在内部通过一个8k Ω 电阻上拉至V _{CCT} 。 |
| 9 | SCL | 串行时钟输入, TTL/CMOS。该引脚具有一个75k Ω 内部下拉电阻。 |
| 10 | SDA | 串行数据双向输入, TTL/CMOS, 开漏输出。该引脚具有一个75k Ω 内部上拉电阻, 但需要一个4.7k Ω 的外部上拉电阻, 以满足3线数字时序要求(防止数据线发生冲突)。 |
| 11 | CSEL | 片选输入, TTL/CMOS。将CSEL设置为逻辑高电平时将启动一次工作过程; 将CSEL设置为逻辑低电平时则终止工作过程, 并复位控制状态机。通过内部75k Ω 电阻下拉至地。 |
| 12, 15, 18, 21 | V _{CCT} | 电源, 为发送电路提供供电电压。 |
| 13 | TIN+ | 同相发送数据输入, CML。 |

1.0625Gbps至10.32Gbps、完全集成的 低功耗SFP+限幅放大器和VCSEL驱动器

引脚说明(续)

| 引脚 | 名称 | 功能 |
|----|-------|---|
| 14 | TIN- | 反相发送数据输入, CML。 |
| 16 | BMON | 偏置电流监测器输出。从该引脚流出的电流在一个外部电阻上产生以地为参考的电压, 电压与激光器偏置电流成正比。 |
| 17 | VEET | 地, 发送电路接地端。 |
| 19 | TOUT- | 反相调制电流输出, 50Ω背板端接至V _{CCT} 。 |
| 20 | TOUT+ | 同相调制电流输出, 50Ω背板端接至V _{CCT} 。 |
| 22 | BIAS | VCSEL偏置电流输出。 |
| 23 | FAULT | 发送器故障输出, 开漏。逻辑高电平表示发生故障。发生故障后, 即使在故障条件清除情况下, FAULT仍保持高电平。故障条件清除后, 通过DISABLE信号清除故障锁定, 使其变为低电平。 |
| 24 | BMAX | 模拟VCSEL偏置电流限制。连接在BMAX和V _{CCT} 之间的电阻设置最大允许的VCSEL偏流。 |
| 25 | MMAX | 模拟VCSEL调制电流限值。连接在MMAX和V _{CCT} 之间的电阻设置最大允许的VCSEL调制电流。 |
| 26 | VEER | 地, 接收电路接地端。 |
| 28 | RIN- | 反相接收数据输入, CML。 |
| 29 | RIN+ | 同相接收数据输入, CML。 |
| 31 | CAZ2 | 失调修正环路电容。连接在该引脚和CAZ1之间的电容用于设置失调修正环路的时间常数。通过数字接口设置控制位AZ_EN = 0, 可禁用失调修正。 |
| 32 | CAZ1 | 失调修正环路电容。与CAZ2相对应, 内部连接至V _{EEER} 。 |
| — | EP | 裸焊盘, 地。必须焊接至电路板地, 以保证散热和电气性能(请参考裸焊盘封装部分)。 |

详细说明

MAX3798 SFP+收发器集成了带信号丢失检测功能的限幅放大器接收器和带故障保护功能的VCSEL激光驱动发送器。控制器通过3线接口实现MAX3798的高级Rx和Tx配置, MAX3798提供多个电流和电压DAC, 允许配合使用低成本控制器IC。

限幅放大器接收器

MAX3798内部限幅放大器接收器的工作速率为1.0625Gbps至10.32Gbps。接收器包括一个双通道限幅器、失调修正电路、带去加重功能的CML输出级和信号丢失检测电路。接收功能可通过片上3线接口控制。控制接收器功能的寄存器有RXCTRL1、RXCTRL2、RXSTAT、MODECTRL、SET_CML和SET_LOS。

1.0625Gbps至10.32Gbps、完全集成的 低功耗SFP+限幅放大器和VCSEL驱动器

MAX3798



图2. 功能框图

1.0625Gbps至10.32Gbps、完全集成的 低功耗SFP+限幅放大器和VCSEL驱动器

双通道限幅器

限幅放大器包括高增益模式和宽带模式，能够对整体系统进行优化处理。无论MSEL引脚还是MODE_SEL位均可用于模式选择。工作速率在4.25Gbps以下时，建议采用高增益模式(MODE_SEL = 0)；工作速率在8.5Gbps以上时，建议采用宽带模式(MODE_SEL = 1)。工作在8.5Gbps时，模式选择依赖于光接收组件。ROUT+/ROUT-相对于RIN+/RIN-的极性通过RX_POL位设置。

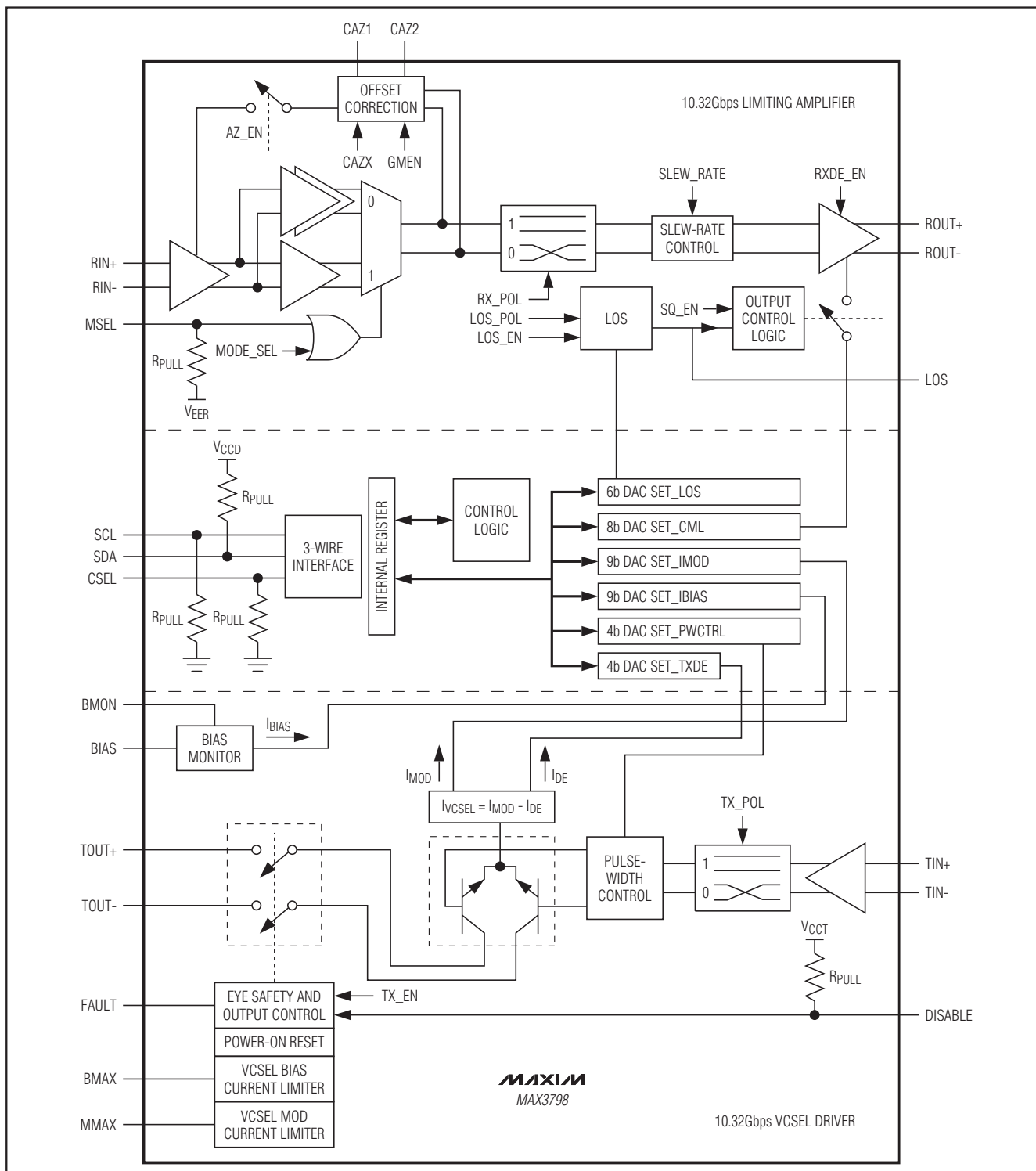
失调修正电路

使能失调修正电路可消除差分放大级固有的失调电压所引起的脉宽失真，利用连接在CAZ1和CAZ2引脚之间的外部电容(C_{AZ})设置失调修正环路的截止频率。失调环路可通过AZ_EN位禁用，MAX3798能够满足10μs的模式选择转换时间，模式选择转换时间可通过GMEN和CAZX位调整。

带有去加重和摆率控制的CML输出级

CML输出级针对100Ω差分负载进行优化。RXDE_EN位可以控制向限幅差分输出信号加入模拟去加重补偿，以补偿SFP连接器损耗。输出级受控于RX_EN和SQ_EN位及LOS引脚的组合，请参考表1。

CML输出级幅度受8位DAC寄存器(SET_CML)控制。差分输出幅度的范围为40mV_{P-P}至1200mV_{P-P}，分辨率为4.6mV_{P-P} (假设采用理想的100Ω差分负载)。

带宽较窄的数据通路可以降低输出的边沿速度，从改善EMI指标。SLEW_RATE位用于控制输出级的摆率(参考表2)。

表1. CML输出级工作模式

| RX_EN | SQ_EN | LOS | OPERATION MODE DESCRIPTION |
|-------|-------|-----|----------------------------|
| 0 | X | X | CML output disabled. |
| 1 | 0 | X | CML output enabled. |
| 1 | 1 | 0 | CML output enabled. |
| 1 | 1 | 1 | CML output disabled. |

信号丢失(LOS)检测电路

输入数据幅度与6位DAC寄存器SET_LOS设置的门限相比较，LOS有效电平可在14mV_{P-P}至77mV_{P-P}范围内以1.5mV_{P-P}分辨率进行编程(假设采用理想的100Ω差分源)。LOS通过LOS_EN位使能，LOS极性受LOS_POL位控制。

VCSEL驱动器

MAX3798内部VCSEL驱动器的工作速率为1.0625Gbps至10.32Gbps。发送器包括具有脉宽调整功能的差分数据通路、偏置电流和调制电流DAC、可编程去加重的输出驱动、上电复位电路、BIAS监测器、VCSEL限流器和视觉保护电路，通过3线数字接口控制发送器功能。控制发送器功能的寄存器有TXCTRL、TXSTAT1、TXSTAT2、SET_IBIAS、SET_IMOD、IMODMAX、IBIASMAX、MODINC、BIASINC、MODECTRL、SET_PWCTRL和SET_TXDE。

差分数据通路

CML输入缓冲器优化用于交流耦合信号，内部采用100Ω差分负载端接。差分输入数据用于补偿由SFP连接器引起的高频损耗。TXCTRL寄存器的TX_POL位用于控制TOUT+和TOUT-相对于TIN+和TIN-的极性。SET_PWCTRL寄存器控制输出眼图的交叉调节，状态标识位(TXED)检测是否存在交流输入信号。

表2. CML输出级摆率控制

| MODE_SEL | SLEW_RATE | OPERATION MODE DESCRIPTION |
|----------|-----------|--|
| 0 | 0 | 4.25Gbps operation with reduced output edge speed. |
| 0 | 1 | 4.25Gbps operation with full edge speed; 8.5Gbps operation with high bandwidth ROSA. |
| 1 | X | 8.5Gbps with lower bandwidth ROSA; 10.32Gbps operation. |

1.0625Gbps至10.32Gbps、完全集成的 低功耗SFP+限幅放大器和VCSEL驱动器

偏置电流DAC

MAX3798的偏置电流优化用于向50Ω至75Ω VCSEL负载提供高达15mA的偏置电流，分辨率为40μA。偏置电流由3线数字接口通过SET_IBIAS、IBIASMAX和BIASINC寄存器控制。

为了使VCSEL正常工作，IBIASMAX寄存器首先设置在所要求的最大偏置电流(最大为15mA)。流入VCSEL的偏置电流范围为0至IBIASMAX寄存器的设置值。偏置电流幅值储存在9位SET_IBIAS寄存器，只有第1位至第8位可写。SET_IBIAS的LSB(第0位)初始化为0，并通过BIASINC寄存器刷新。

通过3线接口寻址BIASINC寄存器时，更新SET_IBIAS DAC寄存器值。BIASINC寄存器为8位寄存器，前5位以二进制补码格式储存递增信息。递增范围从-8至+7 LSB。如果SET_IBIAS[8:1]的更新值超过IBIASMAX[7:0]，IBIASERR报警标识置位，而SET_IBIAS[8:0]保持不变。

调制电流DAC

MAX3798的调制电流优化用于向100Ω差分负载提供高达12mA的调制电流，调制电流分辨率为40μA，通过3线数字接口控制SET_IMOD、IMODMAX、MODINC和SET_TXDE寄存器进行设置。

为了使VCSEL正常工作，IMODMAX寄存器首先设置在所要求的最大调制电流(最大为12mA，驱动100Ω差分负载)，流入VCSEL的调制电流为0至IMODMAX寄存器设置值。调制电流幅值储存在9位SET_IMOD寄存器，只有第1位至第8位可写。SET_IMOD的LSB(第0位)初始化为0，并通过MODINC寄存器更新。

通过3线接口寻址MODINC寄存器时，更新SET_IMOD DAC寄存器。MODINC寄存器为8位寄存器，前5位以二进制补码的格式储存递增信息，递增范围从-8至+7 LSB。如果SET_IMOD[8:1]的刷新值超过IMODMAX[7:0]，IMODERR报警标识置位，而SET_IMOD[8:0]保持不变。

输出驱动

输出驱动优化用于交流耦合100Ω差分负载。可编程输出级去加重，将去加重幅值设置为调制电流的一定百分比。去加重功能通过TXDE_EN位使能。初始设置时，可使用SET_TXDE寄存器设置所要求的去加重总量。在系统工作期间，建议使用通过MODINC寄存器同时更新去加重(SET_TXDE)和调制电流DAC(SET_IMOD)的增量模式。

上电复位(POR)

上电复位确保激光器在电压达到规定门限(2.55V)之前处于关闭状态。上电复位后，偏置电流和调制电流缓慢爬升，以避免过冲。POR情况下，所有寄存器被复位到默认值。

偏置电流监测器

BMON的输出电流典型值为 I_{BIAS} 的1/16。BMON端的接地电阻用于设置电压增益。如果BMON电压超过 $V_{CC} - 0.55V$ ，内部比较器将锁存一次软故障。

VCSEL限流器

为了增强视觉保护功能，除数字限流器外，还可使用外部模拟VCSEL限流。BMAX和MMAX处的外部电阻分别限制最大偏置电流和调制电流，如果VCSEL电流超过该门限，将锁存一次硬故障。

视觉保护和输出控制电路

视觉保护和输出控制电路包括一个禁用引脚(DISABLE)和禁用位(TX_EN)，以及故障指示和故障监测器(图3)。MAX3798有两种故障：硬故障和软故障。硬故障触发FAULT引脚报警，并禁止VCSEL输出；软故障的工作方式更像一种报警，并不禁用输出。两种类型的故障储存在TXSTAT1和TXSTAT2寄存器。

FAULT引脚为锁存输出，可通过触发DISABLE引脚清除锁存状态。触发DISABLE引脚还会清零TXSTAT1和TXSTAT2寄存器。单点故障可能是对 V_{CC} 或GND短路，表3所示为不同单点故障下的电路响应。

1.0625Gbps至10.32Gbps、完全集成的 低功耗SFP+限幅放大器和VCSEL驱动器



图3. 视觉保护电路

1.0625Gbps至10.32Gbps、完全集成的 低功耗SFP+限幅放大器和VCSEL驱动器

MAX3798

表3. 单点故障的电路响应

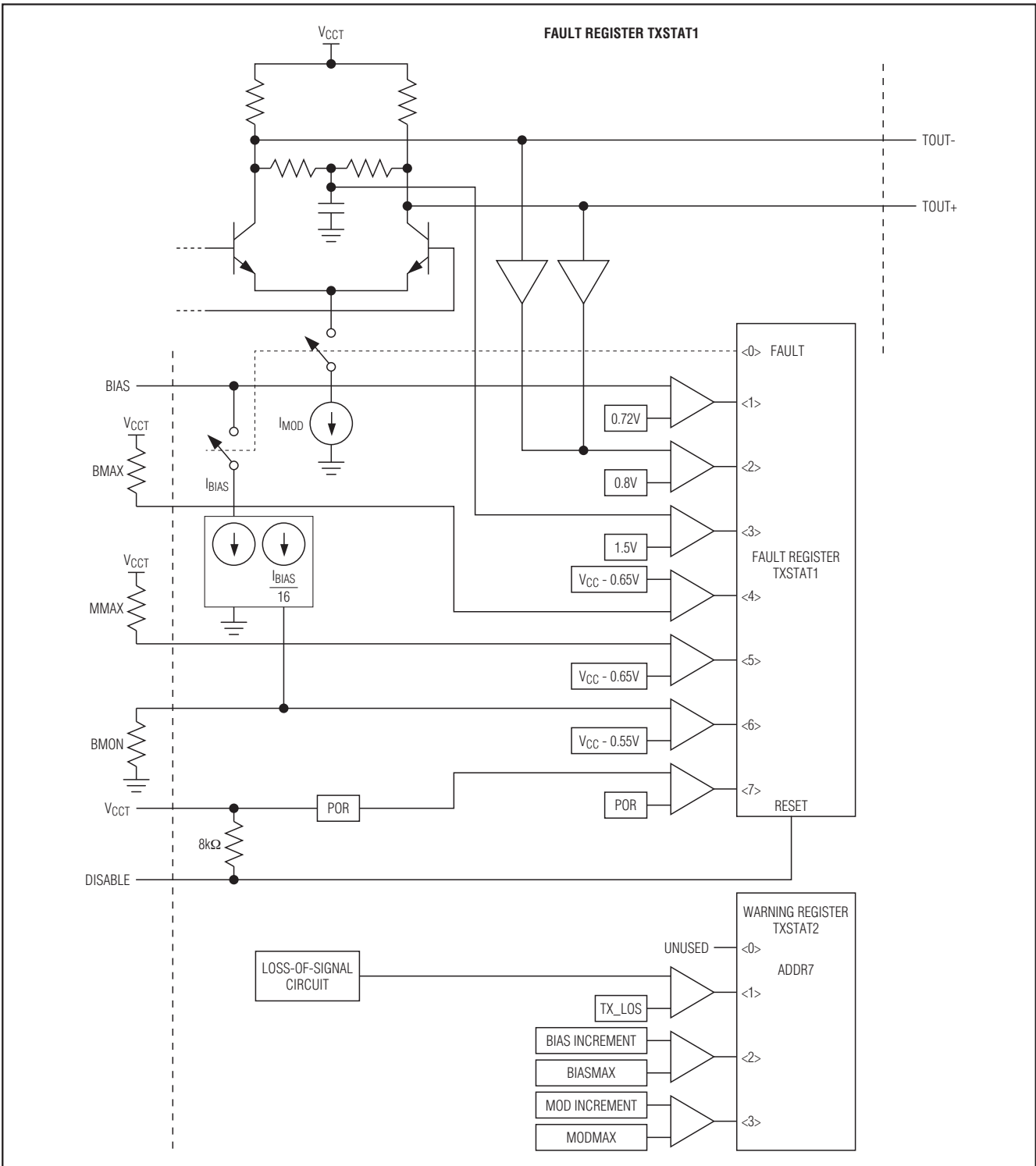
| PIN | NAME | SHORT TO V _{CC} | SHORT TO GND | OPEN |
|-----|------------------|---|---|--------------------------------|
| 1 | LOS | Normal (Note 1) | Normal (Note 1) | Normal (Note 1) |
| 2 | MSEL | Normal (Note 1) | Normal (Note 1) | Normal (Note 1) |
| 3 | V _{CCR} | Normal | Disabled—HARD FAULT (external supply shorted) (Note 2) | Normal (Note 3)—Redundant path |
| 4 | ROUT+ | Normal (Note 1) | Normal (Note 1) | Normal (Note 1) |
| 5 | ROUT- | Normal (Note 1) | Normal (Note 1) | Normal (Note 1) |
| 6 | V _{CCR} | Normal | Disabled—HARD FAULT (external supply shorted) (Note 2) | Normal (Note 3)—Redundant path |
| 7 | V _{CCD} | Normal | Disabled—HARD FAULT | Disabled—HARD FAULT |
| 8 | DISABLE | Disabled | Normal (Note 1). Can only be disabled with other means. | Disabled |
| 9 | SCL | Normal (Note 1) | Normal (Note 1) | Normal (Note 1) |
| 10 | SDA | Normal (Note 1) | Normal (Note 1) | Normal (Note 1) |
| 11 | CSEL | Normal (Note 1) | Normal (Note 1) | Normal (Note 1) |
| 12 | V _{CCT} | Normal | Disabled—Fault (external supply shorted) (Note 2) | Normal (Note 3)—Redundant path |
| 13 | TIN+ | SOFT FAULT | SOFT FAULT | Normal (Note 1) |
| 14 | TIN- | SOFT FAULT | SOFT FAULT | Normal (Note 1) |
| 15 | V _{CCT} | Normal | Disabled—Fault (external supply shorted) (Note 2) | Normal (Note 3)—Redundant path |
| 16 | BMON | Disabled—HARD FAULT | Normal (Note 1) | Disabled—HARD FAULT |
| 17 | V _{EET} | Disabled—Fault (external supply shorted) (Note 2) | Normal | Disabled—HARD FAULT |
| 18 | V _{CCT} | Normal | Disabled—Fault (external supply shorted) (Note 2) | Normal (Note 3)—Redundant path |
| 19 | TOUT- | I _{MOD} is reduced | Disabled—HARD FAULT | I _{MOD} is reduced |
| 20 | TOUT+ | I _{MOD} is reduced | Disabled—HARD FAULT | I _{MOD} is reduced |
| 21 | V _{CCT} | Normal | Disabled—Fault (external supply shorted) (Note 2) | Normal (Note 3)—Redundant path |
| 22 | BIAS | I _{BIAS} is on—No Fault | Disabled—HARD FAULT | Disabled—HARD FAULT |
| 23 | FAULT | Normal (Note 1) | Normal (Note 1) | Normal (Note 1) |
| 24 | BMAX | Normal (Note 1) | Disabled—HARD FAULT | Disabled—HARD FAULT |
| 25 | MMAX | Normal (Note 1) | Disabled—HARD FAULT | Disabled—HARD FAULT |
| 26 | V _{EER} | Disabled—Fault (external supply shorted) (Note 2) | Normal | Normal (Note 3)—Redundant path |
| 27 | V _{CCR} | Normal | Disabled—HARD FAULT (external supply shorted) (Note 2) | Normal (Note 3)—Redundant path |
| 28 | RIN- | Normal (Note 1) | Normal (Note 1) | Normal (Note 1) |
| 29 | RIN+ | Normal (Note 1) | Normal (Note 1) | Normal (Note 1) |
| 30 | V _{CCR} | Normal | Disabled—Fault (external supply shorted) (Note 2) | Normal (Note 3)—Redundant path |

1.0625Gbps至10.32Gbps、完全集成的 低功耗SFP+限幅放大器和VCSEL驱动器

表3. 单点故障的电路响应(续)

| PIN | NAME | SHORT TO V _{CC} | SHORT TO GND | OPEN |
|-----|----------------|---|--------------------------------|--------------------------------|
| 31 | CAZ2 | Normal (Note 1) | Normal (Note 1) | Normal (Note 1) |
| 32 | CAZ1 (VEER) | Disabled—Fault (external supply shorted) (Note 2) | Normal (Note 3)—Redundant path | Normal (Note 3)—Redundant path |

注1: 正常—不影响激光器功率。

注2: 假设电源短路电流主要位于电路板上(本器件之外), 主电源由于短路损坏。

注3: 功能正常, 但性能会受影响。

警告: 有些引脚短路至V_{CC}或对地短路会超出Absolute Maximum Ratings。

3线数字通信

MAX3798采用专用的3线数字接口, 由外部控制器产生时钟。3线接口由SDA双向数据线、SCL时钟信号输入和CSEL片选输入(高电平有效)组成。外部主控制器通过使能CSEL引脚启动一次数据传输。主控制器在CSEL引脚置1后开始产生时钟信号, 所有的数据传输均为最高有效位(MSB)在前。

协议

每次操作包括16位传输(15位地址/数据, 1位RWN)。总线主控制器向SCL发出16个时钟周期, 所有操作向MAX3798传输8位数据, RWN位决定是写操作还是读操作, 请参考表4。

寄存器地址

MAX3798具有17个可编程寄存器, 表5列出了寄存器及其地址。

写模式(RWN = 0)

主控制器在SCL上共产生16个时钟周期, 主控制器在时钟下降沿向SDA线上共输出16位数据(MSB在前)。主控制器通过将CSEL置0终止传输, 图4所示为接口时序。

读模式(RWN = 1)

主控制器在SCL上共产生16个时钟周期, 主控制器在时钟下降沿向SDA线上共输出8位数据(MSB在前)。发送RWN位后释放SDA, 从器件在时钟的上升沿输出8位数据(MSB在前)。主控制器通过将CSEL置0终止传输, 图4所示为接口时序。

模式控制

常规模式下允许对MODINC和BIASINC以外的所有寄存器执行只读命令。常规模式下可以更新MODINC和BIASINC寄存器, 这种操作可以将通过3线接口控制激光器的刷新速率提高2倍。常规模式为默认模式。

设置模式允许主控制器向状态寄存器(TXSTAT1、TXSTAT2和RXSTAT)以外的所有寄存器写入不受限制的数据。为了进入设置模式状态, MODECTRL寄存器(地址为H0x0E)必须设置为H0x12。在MODECTRL寄存器置为H0x12后, 随后的操作不再受限。在下一操作完成之后, 自动退出设置模式状态。如果需要多次不受限设置, 则必须重复这一过程。

表4. 数字通信字结构

| BIT | | | | | | | | | | | | | | | | |
|------------------|----|----|----|----|----|---|---|-----|-------------------------------|---|---|---|---|---|---|--|
| 15 | 14 | 13 | 12 | 11 | 10 | 9 | 8 | 7 | 6 | 5 | 4 | 3 | 2 | 1 | 0 | |
| Register Address | | | | | | | | RWN | Data that is written or read. | | | | | | | |

1.0625Gbps至10.32Gbps、完全集成的 低功耗SFP+限幅放大器和VCSEL驱动器

表5. 寄存器说明和地址

| ADDRESS | NAME | FUNCTION |
|---------|------------|---|
| H0x00 | RXCTRL1 | Receiver Control Register 1 |
| H0x01 | RXCTRL2 | Receiver Control Register 2 |
| H0x02 | RXSTAT | Receiver Status Register |
| H0x03 | SET_CML | Output CML Level Setting Register |
| H0x04 | SET_LOS | LOS Threshold Level Setting Register |
| H0x05 | TXCTRL | Transmitter Control Register |
| H0x06 | TXSTAT1 | Transmitter Status Register 1 |
| H0x07 | TXSTAT2 | Transmitter Status Register 2 |
| H0x08 | SET_IBIAS | Bias Current Setting Register |
| H0x09 | SET_IMOD | Modulation Current Setting Register |
| H0x0A | IMODMAX | Maximum Modulation Current Setting Register |
| H0x0B | IBIASMAX | Maximum Bias Current Setting Register |
| H0x0C | MODINC | Modulation Current Increment Setting Register |
| H0x0D | BIASINC | Bias Current Increment Setting Register |
| H0x0E | MODECTRL | Mode Control Register |
| H0x0F | SET_PWCTRL | Transmitter Pulse-Width Control Register |
| H0x10 | SET_TXDE | Transmitter Deemphasis Control Register |



图4. 3线数字接口的时序

1.0625Gbps至10.32Gbps、完全集成的 低功耗SFP+限幅放大器和VCSEL驱动器

寄存器说明

接收器控制寄存器1 (RXCTRL1)

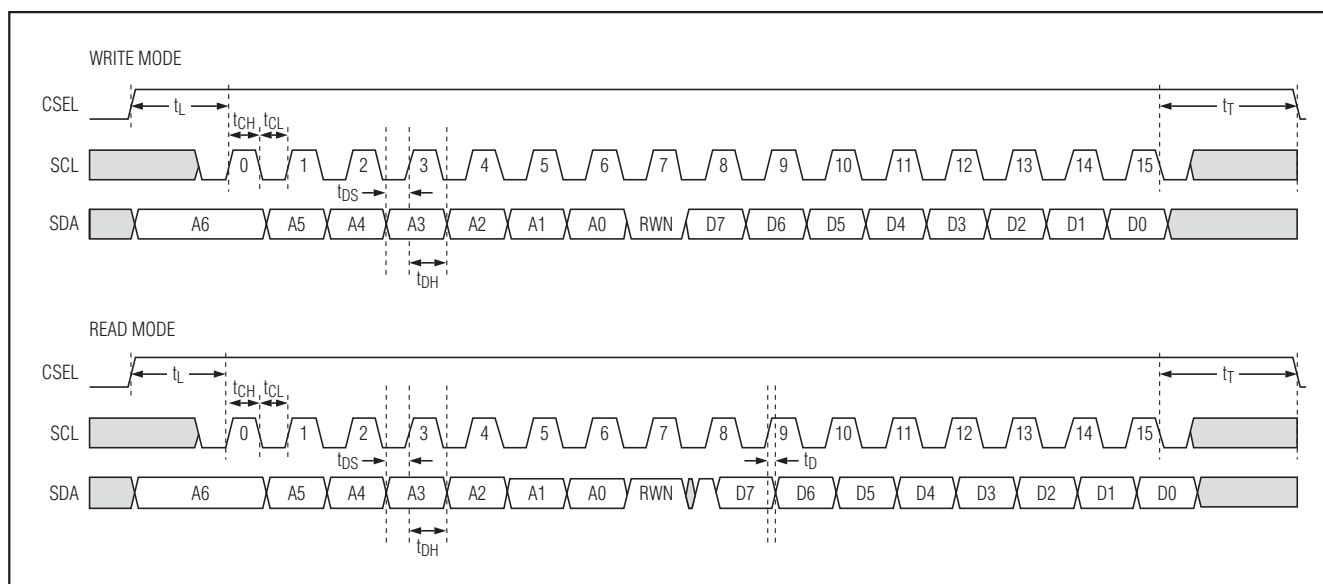
| Bit # | 7 | 6 | 5 | 4 | 3 | 2 | 1 | 0 | ADDRESS |
|---------------|---|---|---|---|------|------|----------|-----------|---------|
| Name | X | X | X | X | CAZX | GMEN | MODE_SEL | SLEW_RATE | H0x00 |
| Default Value | X | X | X | X | 1 | 1 | 0 | 0 | |

第3位：CAZX。当CAZX置0时，不需要外部电容(CAZ1和CAZ2)；当CAZX置1时，CAZ1和CAZ2之间需要一个至少2nF的电容。

0 = 无电容

1 = 连接电容

第2位：GMEN。允许数据通路之间快速切换。

0 = 禁止

1 = 使能

第1位：MODE_SEL。MODE_SEL与MSEL引脚通过逻辑或选择高增益模式(1.0625Gbps至8.5Gbps)或宽带模式(1.0625Gbps至10.32Gbps)。

逻辑或输出0 = 高增益模式

逻辑或输出1 = 宽带模式

第0位：SLEW_RATE。控制输出级摆率，在低速数据传输时可以降低EMI的影响。仅当MODE_SEL = 0且MSEL = GND时有效。

0 = 50ps

1 = 30ps

接收器控制寄存器2 (RXCTRL2)

| Bit # | 7 | 6 | 5 | 4 | 3 | 2 | 1 | 0 | ADDRESS |
|---------------|---|--------|---------|--------|-------|-------|---------|-------|---------|
| Name | X | LOS_EN | LOS_POL | RX_POL | SQ_EN | RX_EN | RXDE_EN | AZ_EN | H0x01 |
| Default Value | X | 1 | 1 | 1 | 0 | 1 | 0 | 1 | |

第6位：LOS_EN。控制LOS电路，当RX_EN置0时，也将禁用LOS检测器。

0 = 禁用

1 = 使能

第5位：LOS_POL。控制LOS引脚的输出极性。

0 = 反相

1 = 正常

第4位：RX_POL。控制接收器信号通路的极性。

0 = 反相

1 = 正常

第3位：SQ_EN。当SQ_EN = 1时，LOS控制输出电路。

0 = 禁用

1 = 使能

1.0625Gbps至10.32Gbps、完全集成的 低功耗SFP+限幅放大器和VCSEL驱动器

第2位: RX_EN。使能或禁用接收器电路。

0 = 禁用

1 = 使能

第1位: RXDE_EN。使能或禁用接收器输出的去加重。

0 = 禁用

1 = 使能

第0位: AZ_EN。使能或禁用自动调零电路。当RX_EN置0时，也将禁用自动调零电路。

0 = 禁用

1 = 使能

接收器状态寄存器(RXSTAT)

| Bit # | 7 | 6 | 5 | 4 | 3 | 2 | 1 | 0 (STICKY) | ADDRESS |
|---------------|---|---|---|---|---|---|---|---------------|---------|
| Name | X | X | X | X | X | X | X | LOS | H0x02 |
| Default Value | X | X | X | X | X | X | X | X | |

第0位: LOS。LOS电路输出的拷贝。这是一个关联位，读操作后清零。第一次逻辑0至逻辑1变化时被锁存，直到主控制器读取该位后或POR后清零。

输出CML电平设置寄存器(SET_CML)

| Bit # | 7 | 6 | 5 | 4 | 3 | 2 | 1 | 0 | ADDRESS |
|---------------|---------------------|------------|------------|------------|------------|------------|------------|---------------------|---------|
| Name | SET_CML[7] (MSB) | SET_CML[6] | SET_CML[5] | SET_CML[4] | SET_CML[3] | SET_CML[2] | SET_CML[1] | SET_CML[0] (LSB) | H0x03 |
| Default Value | 0 | 1 | 0 | 1 | 0 | 0 | 1 | 1 | |

第7位至第0位: SET_CML[7:0]。SET_CML寄存器为8位寄存器，数值范围从0至255，对应于40mV_{P.P}至1200mV_{P.P}。关于典型CML输出电压和DAC编码之间关系的信息，请参考典型工作特性部分。

LOS门限电平设置寄存器(SET_LOS)

| Bit # | 7 | 6 | 5 | 4 | 3 | 2 | 1 | 0 | ADDRESS |
|---------------|---|---|---------------------|------------|------------|------------|------------|---------------------|---------|
| Name | X | X | SET_LOS[5] (MSB) | SET_LOS[4] | SET_LOS[3] | SET_LOS[2] | SET_LOS[1] | SET_LOS[0] (LSB) | H0x04 |
| Default Value | X | X | 0 | 0 | 1 | 1 | 0 | 0 | |

第5位至第0位: SET_LOS[5:0]。SET_LOS寄存器为6位寄存器，用于设置LOS门限。关于典型LOS门限电压和DAC编码之间关系的信息，请参考典型工作特性部分。

1.0625Gbps至10.32Gbps、完全集成的 低功耗SFP+限幅放大器和VCSEL驱动器

发送器控制寄存器(TXCTRL)

| Bit # | 7 | 6 | 5 | 4 | 3 | 2 | 1 | 0 | ADDRESS |
|---------------|---|---|---|---|---------|---------|--------|-------|---------|
| Name | X | X | X | X | TXDE_EN | SOFTRES | TX_POL | TX_EN | H0x05 |
| Default Value | X | X | X | X | 0 | 0 | 1 | 1 | |

第3位：TXDE_EN。使能或禁止发送器输出加重电路。

0 = 禁用

1 = 使能

第2位：SOFTRES。将所有寄存器复位到其默认值。

0 = 正常

1 = 复位

第1位：TX_POL。控制发送信号通路的极性。

0 = 反相

1 = 正常

第0位：TX_EN。使能或禁用发送电路。

0 = 禁用

1 = 使能

发送器状态寄存器1 (TXSTAT1)

| Bit # | 7 (STICKY) | 6 (STICKY) | 5 (STICKY) | 4 (STICKY) | 3 (STICKY) | 2 (STICKY) | 1 (STICKY) | 0 (STICKY) | ADDRESS |
|---------------|---------------|---------------|---------------|---------------|---------------|---------------|---------------|---------------|---------|
| Name | FST[7] | FST[6] | FST[5] | FST[4] | FST[3] | FST[2] | FST[1] | TX_FAULT | H0x06 |
| Default Value | X | X | X | X | X | X | X | X | |

第7位：FST[7]。当V_{CCT}电源电压低于2.45V时，POR电路报告故障。一旦V_{CCT}电源电压高于2.55V，POR将所有寄存器复位到其默认值，并清除FAULT。

第6位：FST[6]。当BMON电压高于V_{CC} - 0.55V时，报告一次软故障。

第5位：FST[5]。当MMAX电压低于V_{CC} - 0.65V时，报告一次硬故障。

第4位：FST[4]。当BMAX电压低于V_{CC} - 0.65V时，报告一次硬故障。

第3位：FST[3]。当V_{TOUT+/-}的共模电压低于1.5V时，报告一次软故障。

第2位：FST[2]。当V_{TOUT+/-}上的电压低于0.8V时，会报告一个硬故障。

第1位：FST[1]。当BIAS电压低于0.44V时，报告一次硬故障。

第0位：TX_FAULT。FST[7]至FST[1]中FAULT信号的拷贝，POR将FST[7:1]复位至0。

发送器状态寄存器2 (TXSTAT2)

| Bit # | 7 | 6 | 5 | 4 | 3 (STICKY) | 2 (STICKY) | 1 (STICKY) | 0 (STICKY) | ADDRESS |
|---------------|---|---|---|---|---------------|---------------|---------------|---------------|---------|
| Name | X | X | X | X | IMODERR | IBIASERR | TXED | X | H0x07 |
| Default Value | X | X | X | X | X | X | X | X | |

第3位：IMODERR。当调制增量结果大于IMODMAX时，报告一次软故障(请参考设置调制电流部分)。

1.0625Gbps至10.32Gbps、完全集成的 低功耗SFP+限幅放大器和VCSEL驱动器

第2位：IBIASERR。当偏置电流增量结果大于IBIASMAX时，报告一次软故障(请参考设置偏置电流部分)。

第1位：TXED。仅表示发送器输入没有交流信号，并非LOS指示。

偏置电流设置寄存器(SET_IBIAS)

| Bit # | 7 | 6 | 5 | 4 | 3 | 2 | 1 | 0 | ADDRESS |
|---------------|---------------------|---------------|---------------|---------------|---------------|---------------|---------------|---------------|---------|
| Name | SET_IBIAS [8] (MSB) | SET_IBIAS [7] | SET_IBIAS [6] | SET_IBIAS [5] | SET_IBIAS [4] | SET_IBIAS [3] | SET_IBIAS [2] | SET_IBIAS [1] | H0x08 |
| Default Value | 0 | 0 | 0 | 0 | 0 | 1 | 0 | 0 | |

第7位至第0位：SET_IBIAS[8:1]。偏置电流DAC共受9位数据控制。SET_IBIAS[8:1]位用于设置从0至510之间偏置电流的偶数值。LSB (SET_IBIAS[0])位受BIASINC寄存器控制，用来设置SET_IBIAS[8:0]偏置电流的奇数值。

调制电流设置寄存器(SET_IMOD)

| Bit # | 7 | 6 | 5 | 4 | 3 | 2 | 1 | 0 | ADDRESS |
|---------------|--------------------|--------------|--------------|--------------|--------------|--------------|--------------|--------------|---------|
| Name | SET_IMOD [8] (MSB) | SET_IMOD [7] | SET_IMOD [6] | SET_IMOD [5] | SET_IMOD [4] | SET_IMOD [3] | SET_IMOD [2] | SET_IMOD [1] | H0x09 |
| Default Value | 0 | 0 | 0 | 1 | 0 | 0 | 1 | 0 | |

第7位至第0位：SET_IMOD[8:1]。调制电流DAC共受9位数据控制。SET_IMOD[8:1]位用于设置从0至510之间调制电流的偶数值。LSB (SET_IMOD[0])位受MODINC寄存器控制，用来设置SET_IMOD[8:0]中的奇数值。

最大调制电流设置寄存器(IMODMAX)

| Bit # | 7 | 6 | 5 | 4 | 3 | 2 | 1 | 0 | ADDRESS |
|---------------|-------------------|-------------|-------------|-------------|-------------|-------------|-------------|-------------------|---------|
| Name | IMODMAX [7] (MSB) | IMODMAX [6] | IMODMAX [5] | IMODMAX [4] | IMODMAX [3] | IMODMAX [2] | IMODMAX [1] | IMODMAX [0] (LSB) | H0x0A |
| Default Value | 0 | 0 | 1 | 1 | 0 | 0 | 0 | 0 | |

第7位至第0位：IMODMAX[7:0]。IMODMAX寄存器为8位寄存器，用于限制最大调制电流。连续比较IMODMAX[7:0]与SET_IMOD[8:1]。

最大偏置电流设置寄存器(IBIASMAX)

| Bit # | 7 | 6 | 5 | 4 | 3 | 2 | 1 | 0 | ADDRESS |
|---------------|--------------------|--------------|--------------|--------------|--------------|--------------|--------------|--------------------|---------|
| Name | IBIASMAX [7] (MSB) | IBIASMAX [6] | IBIASMAX [5] | IBIASMAX [4] | IBIASMAX [3] | IBIASMAX [2] | IBIASMAX [1] | IBIASMAX [0] (LSB) | H0x0B |
| Default Value | 0 | 0 | 0 | 1 | 0 | 0 | 1 | 0 | |

第7位至第0位：IBIASMAX[7:0]。IBIASMAX寄存器为8位寄存器，用于限制最大偏置电流。连续比较IBIASMAX[7:0]与SET_IBIAS[8:1]。

1.0625Gbps至10.32Gbps、完全集成的 低功耗SFP+限幅放大器和VCSEL驱动器

调制电流递增设置寄存器(MODINC)

| Bit # | 7 | 6 | 5 | 4 | 3 | 2 | 1 | 0 | ADDRESS |
|---------------|-------------|---|--------|-----------------|-----------|-----------|-----------|-----------------|---------|
| Name | SET_IMOD[0] | X | DE_INC | MODINC[4] (MSB) | MODINC[3] | MODINC[2] | MODINC[1] | MODINC[0] (LSB) | H0x0C |
| Default Value | 0 | 0 | 0 | 0 | 0 | 0 | 0 | 0 | |

第7位：SET_IMOD[0]。该位是SET_IMOD[8:0]位的最低有效位，仅可利用MODINC[4:0]进行更新。

第5位：DE_INC。该位置1，并且发送器输出的去加重使能时，SET_TXDE[3:0]被增加或减少1个LSB。递增或递减由MODINC[4:0]的符号位决定。

第4位至第0位：MODINC[4:0]。这些位用于增大或减小调制电流。写入时，SET_IMOD[8:0]位被更新，MODINC[4:0]为二进制补码。

偏置电流递增设置寄存器(BIASINC)

| Bit # | 7 | 6 | 5 | 4 | 3 | 2 | 1 | 0 | ADDRESS |
|---------------|--------------|---|---|------------------|------------|------------|------------|------------------|---------|
| Name | SET_IBIAS[0] | X | X | BIASINC[4] (MSB) | BIASINC[3] | BIASINC[2] | BIASINC[1] | BIASINC[0] (LSB) | H0x0D |
| Default Value | 0 | 0 | 0 | 0 | 0 | 0 | 0 | 0 | |

第7位：SET_IBIAS[0]。SET_IBIAS[8:0]的最低有效位，仅可利用BIASINC[4:0]进行更新。

第4位至第0位：BIASINC[4:0]。这些位用来增大或减小偏置电流。写入时，SET_IBIAS[8:0]位被更新，BIASINC[4:0]为二进制补码。

模式控制寄存器(MODECTRL)

| Bit # | 7 | 6 | 5 | 4 | 3 | 2 | 1 | 0 | ADDRESS |
|---------------|-------------------|-------------|-------------|-------------|-------------|-------------|-------------|-------------------|---------|
| Name | MODECTRL[7] (MSB) | MODECTRL[6] | MODECTRL[5] | MODECTRL[4] | MODECTRL[3] | MODECTRL[2] | MODECTRL[1] | MODECTRL[0] (LSB) | H0x0E |
| Default Value | 0 | 0 | 0 | 0 | 0 | 0 | 0 | 0 | |

第7位至第0位：MODECTRL[7:0]。MODECTRL寄存器使能常规模式和设置模式之间的转换。将该寄存器置为H0x12时为设置模式状态。MODECTRL必须在每次写操作之前更新。MODINC和BIASINC除外，它们可在常规模式下更新。

发送器脉宽控制寄存器(SET_PWCTRL)

| Bit # | 7 | 6 | 5 | 4 | 3 | 2 | 1 | 0 | ADDRESS |
|---------------|---|---|---|---|---------------------|---------------|---------------|---------------------|---------|
| Name | X | X | X | X | SET_PWCTRL[3] (MSB) | SET_PWCTRL[2] | SET_PWCTRL[1] | SET_PWCTRL[0] (LSB) | H0x0F |
| Default Value | X | X | X | X | 0 | 0 | 0 | 0 | |

第3位至第0位：SET_PWCTRL[3:0]。这是一个4位寄存器，通过调节脉冲宽度控制眼图交叉点。

1.0625Gbps至10.32Gbps、完全集成的 低功耗SFP+限幅放大器和VCSEL驱动器

发送器去加重控制寄存器(SET_TXDE)

MAX3798

| Bit # | 7 | 6 | 5 | 4 | 3 | 2 | 1 | 0 | ADDRESS |
|---------------|---|---|---|---|--------------------|--------------|--------------|--------------------|---------|
| Name | X | X | X | X | SET_TXDE [3] (MSB) | SET_TXDE [2] | SET_TXDE [1] | SET_TXDE [0] (LSB) | H0x10 |
| Default Value | X | X | X | X | 0 | 0 | 0 | 0 | |

第3位至第0位：SET_TXDE[3:0]。这是一个4位寄存器，控制发送器输出的去加重。在计算总调制电流时，必须考虑去加重总和。去加重设置为调制电流的百分比。

设计步骤

设置偏置电流

1) IBIASMAX[7:0] = Maximum_Bias_Current_Value

2) SET_IBIAS_i[8:1] = Initial_Bias_Current_Value

注：利用SET_IBIAS[8:0]寄存器计算总的偏置电流，SET_IBIAS[8:1]位可手动写入。SET_IBIAS[0]只能利用BIASINC[4:0]寄存器更新。

采用APC环路时，建议使用BIASINC[4:0]寄存器，可保证偏置电流更新速率最快。

3) BIASINC_i[4:0] = New_Increment_Value

4) 如果：(SET_IBIAS_i[8:1] ≤ IBIASMAX[7:0])，则：
(SET_IBIAS_i[8:0] = SET_IBIAS_{i-1}[8:0] + BIASINC_i[4:0])

5) 否则：(SET_IBIAS_i[8:0] = SET_IBIAS_{i-1}[8:0])

总偏置电流计算如下：

6) I_{BIAS} = [SET_IBIAS_i[8:0] + 20] × 40μA

设置调制电流

1) IMODMAX[7:0] = Maximum_Modulation_Current_Value

2) SET_IMOD_i[8:1] = Initial_Modulation_Current_Value

注：利用SET_IMOD[8:0]寄存器计算总调制电流。SET_IMOD[8:1]位可手动写入。SET_IMOD[0]只能利用MODINC[4:0]寄存器刷新。

当采用调制补偿时，建议使用MODINC[4:0]寄存器，可保证调制电流的刷新速度最快。

3) MODINC_i[4:0] = New_Increment_Value

4) 如果：(SET_IMOD_i[8:1] ≤ IMODMAX[7:0])，则：
(SET_IMOD_i[8:0] = SET_IMOD_{i-1}[8:0] + MODINC_i[4:0])

5) 否则：(SET_IMOD_i[8:0] = SET_IMOD_{i-1}[8:0])

下式在假设片上100Ω差分电阻和100Ω外部差分负载(Rextd)条件下成立。SET_TXDE[3:0]最大值设置为11。

6) I_{MOD}(Rextd=100Ω) = [(20 + SET_IMOD_i[8:0]) × 40μA]

$$\times \left[1 - \frac{2 + \text{SET_TXDE}[3:0]}{64} \right]$$

对于常用的Rextd，采用与如下Rextd = 100Ω相同的设置设定SET_IMOD_i[8:0]，得到调制电流。它可以作为I_{MOD}(Rextd=100Ω)的一个函数写入，仍假设100Ω片上负载。

7) I_{MOD}(Rextd) = 2 × I_{MOD}(Rextd=100Ω) $\left[\frac{R_{ext}}{R_{ext} + 100} \right]$

编程LOS门限

$$\text{LOSTH} = (\text{SET_LOS}[5:0] \times 1.5\text{mVp-p})$$

设置发送器输出去加重

TXDE_EN位必须置1才能使能去加重功能。SET_TXDE寄存器用于设置去加重量，它是调制电流的一个百分比。去加重百分比由下式确定：

$$\text{DE}(\%) = \frac{100 \times (2 + \text{SET_TXDE}[3:0])}{64}$$

其中，最大SET_TXDE[3:0] = 11。

对于10mA的一个I_{MOD}，最大去加重值大约为20%。对于12mA的满幅I_{MOD}，最大去加重限制为15%。

使能去加重功能时，利用计算出的去加重百分比减小调制电流的幅度。为了保持调制电流幅值恒定，SET_IMOD[8:0]寄存器必须增加去加重百分比。如果系统条件，例如温度、所要求的I_{MOD}等在发送期间发生变化，可能需要重新调整去加重设置。对于这种去加重的临时调整情况，建议使用DE_INC (MODINC[5])位。利用该位可根据MODINC[4:0]的增量符号及此处的SET_IMOD[8:0]设置，将去加重编码增加或减少1个LSB。这有助于在连续发送情况下保持BER，并可灵活地通过适当调整去加重来改善信号质量。这一功能在保持优异的BER性能的同时可以无干扰地调节去加重。

1.0625Gbps至10.32Gbps、完全集成的 低功耗SFP+限幅放大器和VCSEL驱动器

设置脉宽控制

Tx输出的眼图交叉点可利用SET_PWCTRL寄存器进行调整，表6列出了相关设置。

数字符号规定了脉宽偏移方向，编码1111对应于差分输出的平衡状态。脉宽偏移量可围绕平衡状态双向调节(请参见典型工作特性部分)。

表6. SET_PWCTRL的眼图交叉点设置

| SET_PWCTRL[3:0] | PWD | SET_PWCTRL[3:0] | PWD |
|-----------------|-----|-----------------|-----|
| 1000 | -7 | 0111 | 8 |
| 1001 | -6 | 0110 | 7 |
| 1010 | -5 | 0101 | 6 |
| 1011 | -4 | 0100 | 5 |
| 1100 | -3 | 0011 | 4 |
| 1101 | -2 | 0010 | 3 |
| 1110 | -1 | 0001 | 2 |
| 1111 | 0 | 0000 | 1 |

编程CML输出设置

CML输出幅度由8位DAC寄存器(SET_CML)控制。差分输出摆幅范围：40mV_{P-P}至1200mV_{P-P}，分辨率为4.6mV_{P-P}(假设采用理想的100Ω差分负载)。

$$\text{输出电压} R_{\text{OUT}} (\text{mV}_{\text{P-P}}) = 40 + 4.55 (\text{SET_CML})$$

选择耦合电容

对于交流耦合，耦合电容C_{IN}和C_{OUT}的选择应将接收器的确定性抖动降至最小。当输入低频截止点(f_{IN})降低时，抖动会减小。

$$f_{\text{IN}} = 1/[2\pi(50)(C_{\text{IN}})]$$

推荐MAX3798采用0.1μF的C_{IN}和C_{OUT}。

选择失调修正电容

CAZ1和CAZ2之间的电容决定了信号通路直流失调抑制环路的时间常数。为了保持稳定，使f_{IN}和直流失调抑制环路对应的低频截止点(f_{OC})保持至少10倍频的间隔非常重要。建议MAX3798的CAZ1和CAZ2之间使用1nF电容。

应用信息

布局考虑

为了将寄生电感降至最小，MAX3798输出引脚与激光二极管应尽可能靠近安装。在靠近激光二极管阳极的位置安装一个旁路电容，以优化激光二极管性能。采用良好的高频布线工艺以及不间断接地区域的多层电路板，将EMI和串扰降至最小。

裸焊盘封装

32引脚TQFN封装的裸焊盘为IC提供了一条低热阻的散热通道。该焊盘也是MAX3798的电气地，必须焊接到电路板地，以保证散热和电气性能，更多信息请参考应用笔记862: *HFAN-08.1: Thermal Considerations of QFN and Other Exposed-Paddle Packages*。

激光器安全和IEC 825

单独使用MAX3798激光驱动器不能保证发送器设计完全符合IEC 825标准。必须考虑整体发送电路和元件选择。每个用户必须确定具体应用的容错等级，了解Maxim产品并非专门设计用于或授权用于外科移植手术以及生命支持、维持系统的器件，或其它任何可能因为Maxim器件失效而导致人员伤亡的应用。

1.0625Gbps至10.32Gbps、完全集成的 低功耗SFP+限幅放大器和VCSEL驱动器

表7. 寄存器汇总表

| REGISTER FUNCTION/ ADDRESS | REGISTER NAME | NORMAL MODE | SETUP MODE | BIT NUMBER /TYPE | BIT NAME | DEFAULT VALUE | NOTES |
|--|---------------|-------------|------------|------------------|------------|---------------|---|
| Receiver Control Register 1 Address = H0x00 | RXCTRL1 | R | RW | 3 | CAZX | 1 | External autozero capacitor 0: disconnected, 1: connected |
| | | R | RW | 2 | GMEN | 1 | Mode-select switching time boost 0: off, 1: on |
| | | R | RW | 1 | MODE_SEL | 0 | Mode-select 0: high-gain mode, 1: high-bandwidth mode |
| | | R | RW | 0 | SLEW_RATE | 0 | Slew-rate select 0: slow mode, 1: fast mode |
| Receiver Control Register 2 Address = H0x01 | RXCTRL2 | R | RW | 6 | LOS_EN | 1 | LOS control 0: disable, 1: enable (always 0 when RX_EN = 0) |
| | | R | RW | 5 | LOS_POL | 1 | LOS polarity 0: inverse, 1: normal |
| | | R | RW | 4 | RX_POL | 1 | Rx polarity 0: inverse, 1: normal |
| | | R | RW | 3 | SQ_EN | 0 | Squelch 0: disable, 1: enable |
| | | R | RW | 2 | RX_EN | 1 | Rx control 0: disable, 1: enable |
| | | R | RW | 1 | RXDE_EN | 0 | Rx deemphasis 0: disable, 1: enable |
| | | R | RW | 0 | AZ_EN | 1 | Rx autozero control 0: disable, 1: enable (always 0 when RX_EN = 0) |
| Receiver Status Register Address = H0x02 | RXSTAT | R | R | 0 (sticky) | LOS | X | Copy of LOS output signal |
| Output CML Level Setting Register Address = H0x03 | SET_CML | R | RW | 7 | SET_CML[7] | 0 | MSB output level DAC |
| | | R | RW | 6 | SET_CML[6] | 1 | |
| | | R | RW | 5 | SET_CML[5] | 0 | |
| | | R | RW | 4 | SET_CML[4] | 1 | |
| | | R | RW | 3 | SET_CML[3] | 0 | |
| | | R | RW | 2 | SET_CML[2] | 0 | |
| | | R | RW | 1 | SET_CML[1] | 1 | |
| | | R | RW | 0 | SET_CML[0] | 1 | LSB output level DAC |

1.0625Gbps至10.32Gbps、完全集成的 低功耗SFP+限幅放大器和VCSEL驱动器

表7. 寄存器汇总表(续)

| REGISTER FUNCTION/ ADDRESS | REGISTER NAME | NORMAL MODE | SETUP MODE | BIT NUMBER /TYPE | BIT NAME | DEFAULT VALUE | NOTES |
|---|---------------|-------------|------------|------------------|------------|---------------|---|
| LOS Threshold Level Setting Register Address = H0x04 | SET_LOS | R | RW | 5 | SET_LOS[5] | 0 | MSB LOS threshold DAC |
| | | R | RW | 4 | SET_LOS[4] | 0 | |
| | | R | RW | 3 | SET_LOS[3] | 1 | |
| | | R | RW | 2 | SET_LOS[2] | 1 | |
| | | R | RW | 1 | SET_LOS[1] | 0 | |
| | | R | RW | 0 | SET_LOS[0] | 0 | LSB LOS threshold DAC |
| Transmitter Control Register Address = H0x05 | TXCTRL | R | RW | 3 | TXDE_EN | 0 | Tx deemphasis 0: disable, 1: enable |
| | | R | RW | 2 | SOFTRES | 0 | Global digital reset |
| | | R | RW | 1 | TX_POL | 1 | Tx polarity 0: inverse, 1: normal |
| | | R | RW | 0 | TX_EN | 1 | Tx control 0: disable, 1: enable |
| Transmitter Status Register 1 Address = H0x06 | TXSTAT1 | R | R | 7 (sticky) | FST[7] | X | TX_POR → TX_VCC low-limit violation |
| | | R | R | 6 (sticky) | FST[6] | X | BMON open/shorted to VCC |
| | | R | R | 5 (sticky) | FST[5] | X | MMAX current exceeded or open/shorted to GND |
| | | R | R | 4 (sticky) | FST[4] | X | BMAX current exceeded or open/shorted to GND |
| | | R | R | 3 (sticky) | FST[3] | X | V _{TOUT±} common-mode low-limit violation |
| | | R | R | 2 (sticky) | FST[2] | X | V _{TOUT±} low-limit violation |
| | | R | R | 1 (sticky) | FST[1] | X | BIAS open or shorted to GND |
| | | R | R | 0 (sticky) | TX_FAULT | X | Copy of FAULT signal in case POR bits 6 to 1 reset to 0 |
| Transmitter Status Register 2 Address = H0x07 | TXSTAT2 | R | R | 3 (sticky) | IMODERR | X | Warning increment result > IMODMAX |
| | | R | R | 2 (sticky) | IBIASERR | X | Warning increment result > IBIASMAX |
| | | R | R | 1 (sticky) | TXED | X | Tx edge detection |
| | | R | R | 0 (sticky) | Unused | X | Unused |

1.0625Gbps至10.32Gbps、完全集成的 低功耗SFP+限幅放大器和VCSEL驱动器

MAX3798

表7. 寄存器汇总表(续)

| REGISTER FUNCTION/ ADDRESS | REGISTER NAME | NORMAL MODE | SETUP MODE | BIT NUMBER /TYPE | BIT NAME | DEFAULT VALUE | NOTES |
|---|-------------------------------------|-------------|------------|------------------|--------------|---------------|----------------------|
| Bias Current Setting Register Address = H0x08 | SET_IBIAS | R | RW | 8 | SET_IBIAS[8] | 0 | MSB bias DAC |
| | | R | RW | 7 | SET_IBIAS[7] | 0 | |
| | | R | RW | 6 | SET_IBIAS[6] | 0 | |
| | | R | RW | 5 | SET_IBIAS[5] | 0 | |
| | | R | RW | 4 | SET_IBIAS[4] | 0 | |
| | | R | RW | 3 | SET_IBIAS[3] | 1 | |
| | | R | RW | 2 | SET_IBIAS[2] | 0 | |
| | | R | RW | 1 | SET_IBIAS[1] | 0 | |
| | Accessible through REG_ADDR = 13 | | | 0 | SET_IBIAS[0] | 0 | LSB bias DAC |
| Modulation Current Setting Register Address = H0x09 | SET_IMOD | R | RW | 8 | SET_IMOD[8] | 0 | MSB modulation DAC |
| | | R | RW | 7 | SET_IMOD[7] | 0 | |
| | | R | RW | 6 | SET_IMOD[6] | 0 | |
| | | R | RW | 5 | SET_IMOD[5] | 1 | |
| | | R | RW | 4 | SET_IMOD[4] | 0 | |
| | | R | RW | 3 | SET_IMOD[3] | 0 | |
| | | R | RW | 2 | SET_IMOD[2] | 1 | |
| | | R | RW | 1 | SET_IMOD[1] | 0 | |
| | Accessible through REG_ADDR = 12 | | | 0 | SET_IMOD[0] | 0 | LSB modulation DAC |
| Maximum Modulation Current Setting Register Address = H0x0A | IMODMAX | R | RW | 7 | IMODMAX[7] | 0 | MSB modulation limit |
| | | R | RW | 6 | IMODMAX[6] | 0 | |
| | | R | RW | 5 | IMODMAX[5] | 1 | |
| | | R | RW | 4 | IMODMAX[4] | 1 | |
| | | R | RW | 3 | IMODMAX[3] | 0 | |
| | | R | RW | 2 | IMODMAX[2] | 0 | |
| | | R | RW | 1 | IMODMAX[1] | 0 | |
| | | R | RW | 0 | IMODMAX[0] | 0 | LSB modulation limit |
| Maximum Bias Current Setting Register Address = H0x0B | IBIASMAX | R | RW | 7 | IBIASMAX[7] | 0 | MSB bias limit |
| | | R | RW | 6 | IBIASMAX[6] | 0 | |
| | | R | RW | 5 | IBIASMAX[5] | 0 | |
| | | R | RW | 4 | IBIASMAX[4] | 1 | |
| | | R | RW | 3 | IBIASMAX[3] | 0 | |
| | | R | RW | 2 | IBIASMAX[2] | 0 | |
| | | R | RW | 1 | IBIASMAX[1] | 1 | |
| | | R | RW | 0 | IBIASMAX[0] | 0 | LSB bias limit |

1.0625Gbps至10.32Gbps、完全集成的 低功耗SFP+限幅放大器和VCSEL驱动器

表7. 寄存器汇总表(续)

| REGISTER FUNCTION/ ADDRESS | REGISTER NAME | NORMAL MODE | SETUP MODE | BIT NUMBER /TYPE | BIT NAME | DEFAULT VALUE | NOTES |
|---|---------------|-------------|------------|------------------|---------------|---------------|---|
| Modulation Current Increment Setting Register Address = H0x0C | MODINC | R | R | 7 | SET_IMOD[0] | 0 | LSB of SET_IMOD DAC register address = H0x09 |
| | | R | R | 6 | X | 0 | |
| | | R | R | 5 | DE_INC | 0 | Deemphasis increment 0: no update, 1: SET_TXDE updates ± 1 LSB |
| | | RW | RW | 4 | MODINC[4] | 0 | MSB MOD DAC two's complement |
| | | RW | RW | 3 | MODINC[3] | 0 | |
| | | RW | RW | 2 | MODINC[2] | 0 | |
| | | RW | RW | 1 | MODINC[1] | 0 | |
| Bias Current Increment Setting Register Address = H0x0D | BIASINC | R | R | 7 | SET_IBIAS[0] | 0 | LSB of SET_IBIAS DAC register address = H0x08 |
| | | R | R | 6 | X | 0 | |
| | | R | R | 5 | X | 0 | |
| | | RW | RW | 4 | BIASINC[4] | 0 | MSB bias DAC two's complement |
| | | RW | RW | 3 | BIASINC[3] | 0 | |
| | | RW | RW | 2 | BIASINC[2] | 0 | |
| | | RW | RW | 1 | BIASINC[1] | 0 | |
| Mode Control Register Address = H0x0E | MODECTRL | RW | RW | 7 | MODECTRL[7] | 0 | MSB mode control |
| | | RW | RW | 6 | MODECTRL[6] | 0 | |
| | | RW | RW | 5 | MODECTRL[5] | 0 | |
| | | RW | RW | 4 | MODECTRL[4] | 0 | |
| | | RW | RW | 3 | MODECTRL[3] | 0 | |
| | | RW | RW | 2 | MODECTRL[2] | 0 | |
| | | RW | RW | 1 | MODECTRL[1] | 0 | |
| | | RW | RW | 0 | MODECTRL[0] | 0 | LSB mode control |
| Transmitter Pulse-Width Control Register Address = H0x0F | SET_PWCTRL | R | RW | 3 | SET_PWCTRL[3] | 0 | MSB Tx pulse-width control |
| | | R | RW | 2 | SET_PWCTRL[2] | 0 | |
| | | R | RW | 1 | SET_PWCTRL[1] | 0 | |
| | | R | RW | 0 | SET_PWCTRL[0] | 0 | LSB Tx pulse-width control |
| Transmitter Deemphasis Control Register Address = H0x10 | SET_TXDE | R | RW | 3 | SET_TXDE[3] | 0 | MSB Tx deemphasis |
| | | R | RW | 2 | SET_TXDE[2] | 0 | |
| | | R | RW | 1 | SET_TXDE[1] | 0 | |
| | | R | RW | 0 | SET_TXDE[0] | 0 | LSB Tx deemphasis |

1.0625Gbps至10.32Gbps、完全集成的 低功耗SFP+限幅放大器和VCSEL驱动器

MAX3798



图5. I/O结构简化图

1.0625Gbps至10.32Gbps、完全集成的 低功耗SFP+限幅放大器和VCSEL驱动器

典型应用电路

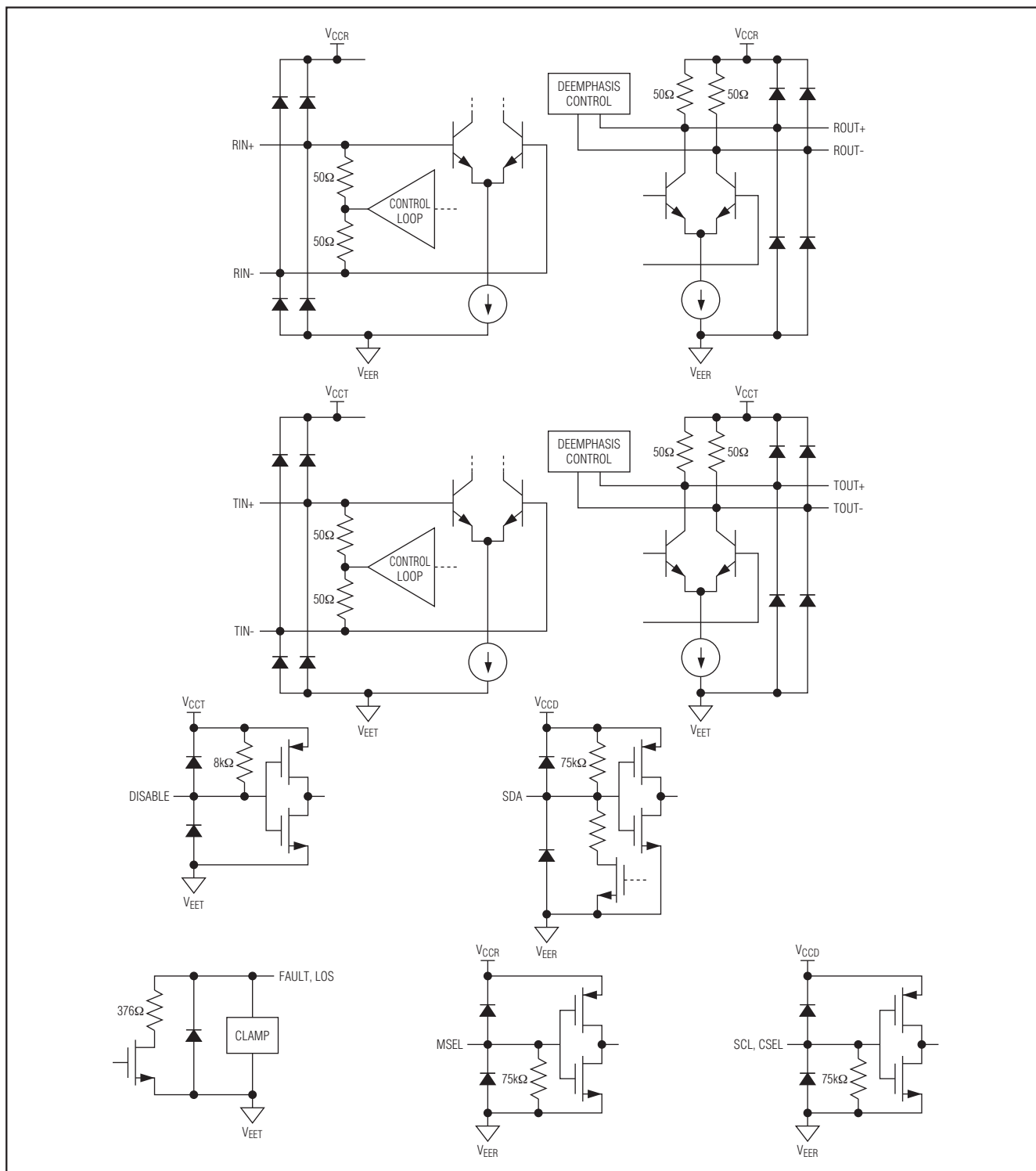
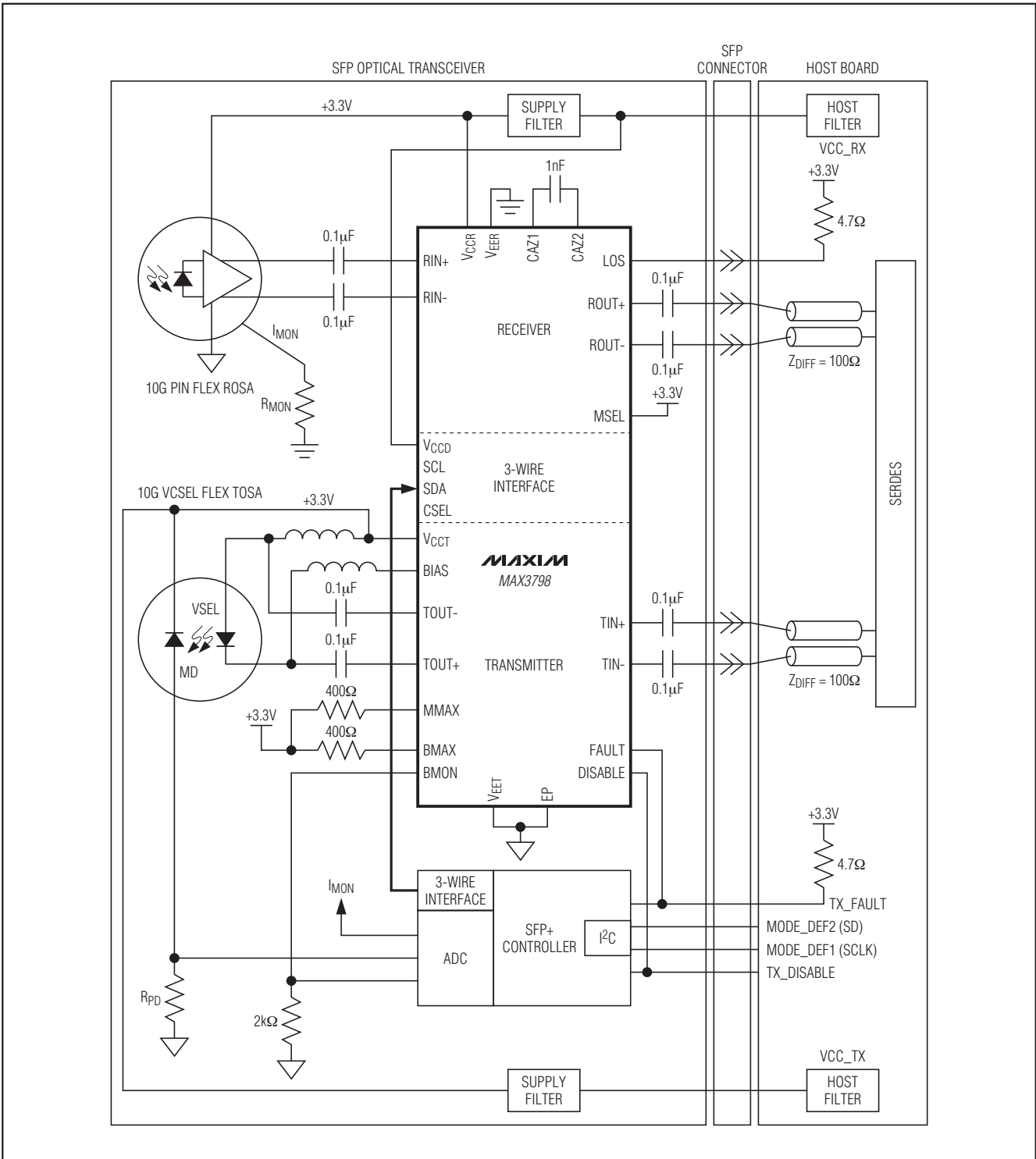

1.0625Gbps至10.32Gbps、完全集成的 低功耗SFP+限幅放大器和VCSEL驱动器

MAX3798

引脚配置

芯片信息

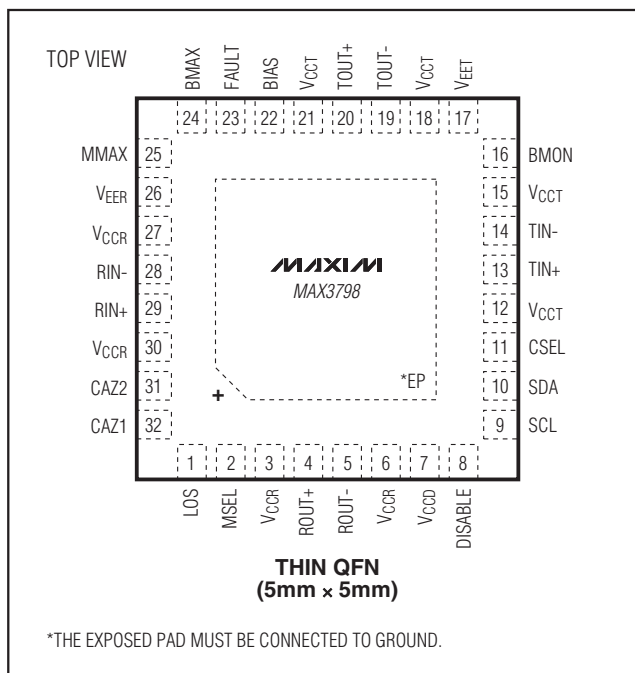

PROCESS: SiGe BiPOLAR

封装信息

如需最近的封装外形信息和焊盘布局, 请查询
china.maxim-ic.com/packages.

| 封装类型 | 封装编码 | 文档编号 |
|------------|---------|-------------------------|
| 32 TQFN-EP | T3255+3 | 21-0140 |

Maxim北京办事处

北京 8328信箱 邮政编码 100083

免费电话: 800 810 0310

电话: 010-6211 5199

传真: 010-6211 5299

Maxim不对Maxim产品以外的任何电路使用负责, 也不提供其专利许可。Maxim保留在任何时间、没有任何通报的前提下修改产品资料和规格的权利。

Maxim Integrated Products, 120 San Gabriel Drive, Sunnyvale, CA 94086 408-737-7600 _____ 35